



Adhesive Application Solutions | ISO 9001 certified

DYNAMELT M210

Adhesive Melt & Supply Unit

with V6 DynaControl with Touch Screen Controller

Technical Documentation, No.20-67, Rev.12.23

English - Original instructions

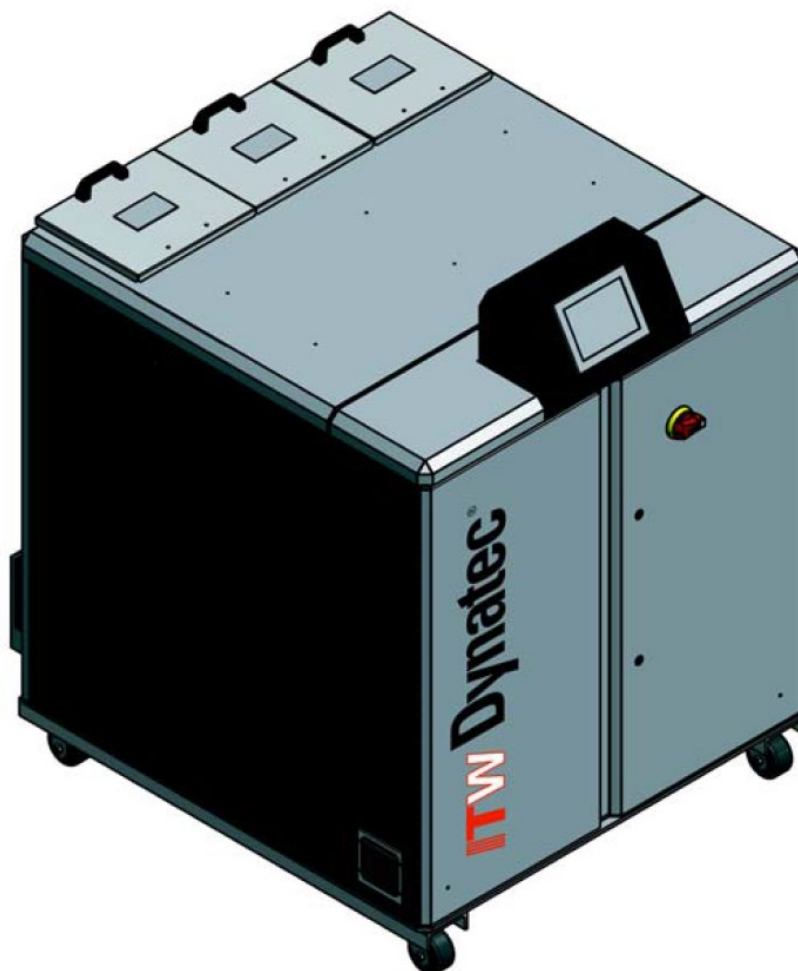

Information about this manual



Read all instructions before operating this equipment!

It is the customer’s responsibility to have all operators and service personnel read and understand this information. Contact your ITW Dynatec customer service representative for additional copies.



NOTICE:

Please be sure to include the serial number of your application system each time you order replacement parts and/or supplies. This will enable us to send you the correct items that you need.

NOTICE:

Most common screws, nuts and washers called out in the manual are not for sale and they can be obtained locally at your hardware Store. Specialty fasteners are available by contacting ITW Dynatec’s Customer Service.

ITW Dynatec Service Parts and Technical Service:

AMERICAS	EUROPE, MIDDLE EAST & AFRICA	ASIA PACIFIC		
ITW Dynatec 31 Volunteer Drive Hendersonville, TN 37075 USA Tel. +1.615.824.3634 info@itwdynatec.com service@itwdynatec.com	ITW Dynatec Industriestrasse 28 40822 Mettmann Germany Tel. +49.2104.915.0 info@itwdynatec.de service@itwdynatec.de	<table border="0"> <tr> <td data-bbox="799 1064 1061 1355"> ITW Dynatec No. 2 Anzhi Street, SIP, Suzhou, 215122 China Tel. +86.512.6289.0620 info@itwdynatec.cn service@itwdynatec.cn </td> <td data-bbox="1066 1064 1396 1355"> ITW Dynatec Tsukimura Building 5th Floor 26-11, Nishikamata 7-chome Ota-ku, Tokyo 144-0051, Japan Tel. +81.3.5703.5501 info@itwdynatec.co.jp service@itwdynatec.co.jp </td> </tr> </table>	ITW Dynatec No. 2 Anzhi Street, SIP, Suzhou, 215122 China Tel. +86.512.6289.0620 info@itwdynatec.cn service@itwdynatec.cn	ITW Dynatec Tsukimura Building 5th Floor 26-11, Nishikamata 7-chome Ota-ku, Tokyo 144-0051, Japan Tel. +81.3.5703.5501 info@itwdynatec.co.jp service@itwdynatec.co.jp
ITW Dynatec No. 2 Anzhi Street, SIP, Suzhou, 215122 China Tel. +86.512.6289.0620 info@itwdynatec.cn service@itwdynatec.cn	ITW Dynatec Tsukimura Building 5th Floor 26-11, Nishikamata 7-chome Ota-ku, Tokyo 144-0051, Japan Tel. +81.3.5703.5501 info@itwdynatec.co.jp service@itwdynatec.co.jp			

Index

Information about this manual	2
Index	3
Chapter 1 Declaration of Incorporation / Conformity	9
Chapter 2 Safety Instructions	11
2.1 General Considerations.....	11
2.2 Warning Labels	11
2.3 Safety Symbols in this Manual	12
2.4 Safe Installation and Operation	13
2.5 Explosion/ Fire Hazard	13
2.6 Choice of Adhesive	14
2.7 Eye Protection & Protective Clothing	14
2.8 Electrical.....	14
2.9 Lockout/ Tagout.....	15
2.10 High Temperatures.....	15
2.11 High Pressure.....	15
2.12 Protective Covers.....	16
2.13 Servicing, maintenance	16
2.14 Cleaning Recommendation	16
2.15 Secure transport.....	17
2.16 Treatment for Burns from Hot Melt Adhesives	17
2.17 Measures in case of fire	18
2.18 Keep attention to environmental protection standards.....	18
Chapter 3 Description and Technical Specs	19
3.1 Applicable Safety Regulations	19
3.1.1 Intended Use	19
3.1.2 Unintended Use, Examples	19
3.1.3 Residual Risks	19
3.1.4 Technical changes	20
3.1.5 Using foreign components	20
3.1.6 Setting-up operation.....	20
3.2 Description of Dynamelt M Melt & Supply Unit	21
3.2.1 Description	21
3.2.2 Specifications	22
3.2.3 Dimensions	24
3.2.4 Total System Wattage Capacity.....	25
3.2.5 Main Circuit Breaker Determination	25
3.2.6 Definition of Code.....	26
Chapter 4 Installation	27
4.1 Placing the Dynamelt M Melter	27
4.2 To Open/ Close Panel Box Door.....	28
4.3 Installation	28
4.4 Customer Terminal Connections.....	29
4.5 Customer Signal Exchange Interfaces.....	30
4.6 Module & Printed Circuit Board Location Diagram	31
4.7 Electrical Connections and Filter Manifold Arrangement for maximum Head/ Hose Configuration.....	33
4.8 Quality of Compressed Air	34
4.9 Adding Adhesive	34
4.10 Changing the Adhesive Formula.....	34
4.11 Field Installation of Controller Options	34
4.12 Adjusting the Pressure Relief Valve.....	35
4.13 Level Control, Capacitive, Sensor with Amplifier	37
4.14 Typical Start-Up and Shut Down of the Application System Using the Touch Screen.....	38
4.15 Storage and Disposal of the DYNAMELT M Application System	39

Chapter 5 DynaControl V6 Controller	41
5.1 Controller Set-Up.....	41
5.1.1 Software & Hardware Versions.....	41
5.1.2 Temperature Control Functions in General	41
5.1.3 Defining DynaControl Temperature Control Terms	41
5.1.4 Error Indication Faults & Alarms	44
5.1.5 Error Alarms in Status Line	44
5.1.6 Controller's Log Book.....	44
5.1.7 Optional System Status Lights.....	45
5.1.8 Settings for a Typical Operation.....	45
5.1.9 Helpful Tips for the User	45
5.2 Security advice	46
5.3 Program Your System's Parameters.....	47
5.4 Numeric Entry Keypad	47
5.5 Alphabetic Entry Keypad.....	48
5.6 Main Screen	49
5.7 Temperature Zones Set Screen.....	53
5.7.1 Zone On/Off Switch on the Numeric Entry Keypad	54
5.8 Pump Overview Screen.....	55
5.8.1 Pump Control Screen/ Linear Line Speed	57
5.8.2 Extended Pump Mode Settings Screen, Linear Line Speed, Pressure Control	59
5.8.3 Pump Control/ Pressure Control Screen	61
5.8.4 Automatic Ramp Compensation	63
5.9 Control Switch On/Off and Standby Switch.....	65
5.10 Systems Screen	67
5.11 Settings Screen.....	69
5.11.1 Heating Priority Screen	70
5.11.2 Zone Configuration Screen	71
5.11.3 Zone Settings	72
5.11.4 Fieldbus Setup Screen.....	74
5.11.5 General Settings Screen.....	75
5.11.5.1 Temperature Settings	75
5.11.5.2 Standby Settings.....	77
5.11.5.3 Level Control Settings.....	79
5.11.5.4 Pressure Zero Calibration	81
5.11.5.5 Customer Zone Names.....	83
5.11.5.6 Support	85
5.11.6 Recipes Screen.....	86
5.11.7 Time & Scheduler Screen	88
5.11.8 Log Book Screen.....	91
5.11.9 Security Screen.....	92
5.11.10 System Info Screen.....	94
5.11.10.1 License Management Screen	95
5.11.10.2 Software Licenses.....	96
5.12 Acknowledge Button.....	97
5.13 Faults/ Alarms	98
5.14 Operator Response to Error Indication Alarms	98
Chapter 6 Maintenance and Repair Notes	99
6.1 Security advices for maintenance and repair.....	99
6.1.1 Equipment Preparation for Maintenance & Repair	100
6.1.2 Re-Assembly Procedures and General Cautions	100
6.1.3 Cleaning Recommendation.....	100
6.2 Maintenance plan	101
6.3 General Cleaning	102
6.4 Preventive Maintenance.....	102
6.4.1 Preventive Maintenance Schedule	102
6.4.2 Outlet Filter, Checking and Replacement	102
6.4.3 Hose Fittings	105
6.4.4 Fasteners	105
6.4.5 Filter and Shutoff Assembly, Cleaning or Replacement	106

6.4.6 Pump Shaft Leak.....	108
6.4.7 Flushing the System.....	108
6.4.8 Panel Box Fan's Exhaust Filter.....	109
Chapter 7 Troubleshooting.....	111
7.1 General Troubleshooting Notes.....	111
7.1.1 Preliminary Checks: Verify the following before proceeding:.....	111
7.1.2 Error Messages.....	111
7.1.3 Hose/ Applicator Troubleshooting Tip.....	112
7.1.4 High-Temperature Redundant Overtemperature Thermostat.....	112
7.1.5 DynaControl V6 Modules.....	112
7.1.6 Handling Printed Circuit Boards (PCBs).....	113
7.2 V6-Base Module PN 115734.....	114
7.3 V6-Temperature Module PN 115735.....	118
7.3.1 Standard System Zone Tables.....	119
7.4 V6-Power Module PN 823306.....	120
7.5 V6-Motor Module PN 116823.....	122
7.6 Motor Speed Control Drive.....	123
7.6.1 Accessing, Programming and Monitoring Motor Control Parameters.....	124
7.7 V6-Solid State Relay (SSR) Adapter PCB Assembly PN 118584.....	125
7.8 Optional V6-BUS Communications Module, PN 118125.....	126
7.9 V6-Extended I/O Module, PN 117648.....	127
7.10 Optional Printed Circuit Boards.....	127
7.11 Heater and Sensor Resistance Values.....	128
7.12 Error Indication Alarm Troubleshooting Guide.....	130
7.13 Adjustable Adhesive Pressure Relief Valve.....	137
7.14 Operation of the Melter's Gear Pump.....	138
7.14.1 Manual or Automatic Pump Operation.....	138
7.14.2 Pump Output Adjustments.....	138
7.15 Troubleshooting the Melter's Gear Pump.....	139
7.15.1 Gear Pump Priming/ Start-Up.....	139
7.15.2 Gear Pump Troubleshooting Guide.....	140
Chapter 8 Disassembly & Re-assembly Procedures.....	143
8.1 Disassembly Procedures.....	143
8.2 To Remove the Access Doors.....	143
8.3 To Open Junction Box.....	144
8.4 Sensor or Thermostat Replacement.....	145
8.5 To Remove the Manifold Cover.....	145
8.6 Heater Replacement.....	145
8.7 To Remove Rear Cover.....	145
8.8 To Access the RTD Sensor in the Optional Drop-in Grid.....	145
8.9 To Access Electrical Components inside the Panel Box.....	146
8.10 To Access the Pump or Motor.....	147
8.11 Re-Assembly Procedures.....	148
Chapter 9 Available Options & Accessories.....	149
9.1 Pressure Gauge Assembly PN 101175.....	149
9.2 Pre-PSI & Post-PSI Transducers PN 811475; Transducer Assembly PN 814521.....	149
9.3 Drop-in Grids PN 104802.....	149
9.4 High-Temperature Heater Groups.....	149
9.5 Filter Options.....	149
9.6 Level Control Options.....	150
9.7 Pumps and Accessories.....	150
9.8 Gear Pump Repair Kit, PN 103151.....	150
9.9 Two Output, Two Filter Manifold PN 102049.....	150
9.10 Return (re-circulating) Hoses.....	150
9.11 Dual Hopper.....	151
9.12 High Flow Melters.....	151
9.13 DynaControl V6 Controller Options.....	151
9.13.1 System Status Lights PN 116848.....	151
9.13.2 V6 Communications Adapters.....	151

9.13.3 Multi-Melter-System w. Central HMI Kit: PN 118945.....	151
9.14 Signal Isolator PN 117143	151
9.15 Ramp Compensation Kits	152
9.16 Repair Kit PN 109982, for Adjustable Pressure Relief Valve 101840	152
9.17 Harting Connector PN 815146.....	152
9.18 Recommended Service Parts List, M210.....	153
Chapter 10 Component Illustrations and Bill of Materials	155
10.1 Base Assemblies.....	156
10.1.1 Base Assembly, M210 Dual Hopper, PN 106054.....	156
10.1.2 Base Assembly, M210 Single Hopper, PN 106055	156
10.1.3 Base Assembly, M210 High-Flow Hopper, PN 106697	156
10.2 Cabinet & covers assembly, M210, PN 106047	158
10.3 Grid Assemblies	160
10.3.1 Grid Group, Dual Hopper, PN 106042.....	160
10.3.2 Grid Group, Single Hopper, PN 106043	161
10.3.3 Grid Group, Single Hopper, High-Temp Version, PN 804947	162
10.3.4 Filter and Shutoff Asy, right-hand, PN 105968, and high-temp version, PN 804465	163
10.3.5 Filter and Shutoff Asy, left-hand, long, PN 105969, and high-temp version, PN 804948	164
10.4 Filter Manifolds.....	165
10.4.1 Filter Manifold Assembly, Easy-Spin, for dual pump, PN 814016	165
10.4.2 Filter Manifold Assembly, Easy-Spin, for single pump, PN 825653	167
10.4.3 Hi Volume/ Hi Flow Filter & Pressure Relief Assembly, PN 809534	169
10.5 Typical Electrical Panel Box Assembly, M210 DCL V6	171
10.6 Typical Electrical Panel Box Insert Components, M210 DCL V6	173
10.7 Drive Assemblies.....	175
10.8 Gear Pumps & Adapter Kits.....	177
10.8.1 Single Gear Pump Assembly 1.54 cc/rev, PN 100860 and 3.2 cc/rev, PN 100861 .	177
10.8.2 Single Gear Pump Assembly 4.50 cc/rev., PN 100862	178
10.8.3 Dual Gear Pump Assembly 1.54 cc/rev., PN 100863.....	179
10.8.4 Dual Gear Pump Assembly 3.2 cc/rev., PN 100864.....	180
10.8.5 Single Gear Pump Assembly 10 cc/rev., PN 109690	181
10.8.6 Single Gear Pump Assembly 0.15 cc/rev., PN 111253	182
10.8.7 Dual Gear Pump Assembly 0.15 cc/rev., PN 111254.....	183
10.8.8 Single Gear Pump Assembly 0.55 cc/rev., PN 109908	184
10.8.9 Dual Gear Pump Assembly 0.55 cc/rev., PN 109909.....	185
10.8.10 Single Gear Pump Assembly 20 cc/rev., PN 109694	186
10.8.11 Pump Adapter Kit, ZN/TSHA Pump, PN 084E406	187
10.8.12 Pump Adapter Kit, Zenith-Pump PN 084E419.....	187
10.8.13 Pump Adapter Kit 20cc/rev., PN 816067	188
10.9 Pressure Gauge Kit (optional), PN 101175.....	189
10.10 Heater Control Groups, PN 103571, 103572, 103573, 103574.....	190
10.11 Transducer Assembly (Optional), PN 814521	191
10.12 V6 Ramp Compensation Kits.....	192
10.12.1 2-Solenoids-Kit for V6 Ramp Compensation (Optional), PN 821610	192
10.12.2 4-Solenoids-Kit for V6 Ramp Compensation (Optional), PN 821640	193
10.12.3 6-Solenoids-Kit for V6 Ramp Compensation (Optional), PN 821642	194
10.12.4 Mounting Dimensions for Solenoids-Kit.....	195
Chapter 11 Schematics & Engineering Drawings.....	197
11.1 Head Schematic, PN 103117, Rev.B, DynaControl.....	197
11.2 Hose Schematic, PN 101082, Rev.G, DynaControl.....	198
11.3 Level Control Schematic PN 802972 REV.C	199
11.4 Typical Hydraulic Schematic	200
11.5 Grounding diagram, CE mark, PN 804704, Rev.E	201
11.6 Schematics M210 V6 240V Single Hopper, PN 820863U	202
11.7 Schematics M210 V6 240V Dual Hopper, PN 821067T	203
11.8 Schematics M210 V6 400V Single Hopper, PN 820948T.....	204
11.9 Schematics M210 V6 400V Dual Hopper, PN 821070T	205
11.10 Schematics V6 M-series Trigger Wiring, PN 824665.....	206
11.11 Schematics V6 Profinet Option, PN 121436	207

11.12 High-Flow Thermostat Wiring, M210 V6, PN 825199	208
Chapter 12 Appendix.....	209
12.1 DynaControl V6 / Fieldbus Option.....	209
12.2 Coalescing Filter Kit, PN 100055	210
12.3 Gear Pumps	211
12.4 Signal Isolator.....	212
12.5 Pressure Transducer.....	213
Manual Revisions	215

This page intentionally left blank.

Chapter 1

Declaration of Incorporation / Conformity

EC declaration of conformity

according to the Machinery Directive 2006/42/EC, Annex II 1. A



Original

The manufacturer bears the sole responsibility for issuing this declaration of conformity

ITW Dynatec

31 Volunteer Drive

US - 37075 Hendersonville

Person established in the Community authorised to compile the relevant technical documentation

Andreas Pahl

ITW Dynatec GmbH

Industriestraße 28

DE - 40822 Mettmann

Description and identification of the machinery

Product / Article	Adhesive Supply Unit
Project number	DM-M V6
Commercial name	Dynamelt M Series V6 (M35, M70, M140, M210)
Model	M35_M70_M140_M210
Function	Melting and delivery of hot melt adhesives

It is expressly declared that the machinery fulfils all relevant provisions of the following EU Directives or Regulations:

2006/42/EC	Directive 2006/42/EC of the European Parliament and of the Council of 17 May 2006 on machinery, and amending Directive 95/16/EC (recast) (1) Published in L 157/24 of 6/9/2006
2014/30/EU	Directive 2014/30/EU of the European Parliament and of the Council of 26 February 2014 on the harmonisation of the laws of the Member States relating to electromagnetic compatibility (recast) Published in 2014/L 96/79 of 3/29/2014
2014/35/EU	Directive 2014/35/EU of the European Parliament and of the Council of 26 February 2014 on the harmonisation of the laws of the Member States relating to the making available on the market of electrical equipment designed for use within certain voltage limits Published in 2014/L 96/357 of 3/29/2014
2011/65/EU	Directive 2011/65/EU of the European Parliament and of the Council of 8 June 2011 on the restriction of the use of certain hazardous substances in electrical and electronic equipment Published in 2011/L 174/88 of 7/1/2011

Reference to the harmonised standards used, as referred to in Article 7 (2):

EN ISO 13850:2015	Safety of machinery — Emergency stop function — Principles for design (ISO 13850:2015)
EN 60204-1:2018	Safety of machinery - Electrical equipment of machines - Part 1: General requirements (IEC 60204-1:2016, modified)
EN ISO 13854:2019	Safety of machinery - Minimum gaps to avoid crushing of parts of the human body (ISO 13854:2017)
EN ISO 12100:2010	Safety of machinery - General principles for design - Risk assessment and risk reduction (ISO 12100:2010)

Hendersonville, 3/17/2023

Place, Date

Signature
Rushton Heidi
VP/GM

Signature
Wallner Michael
Operations Manager EMEA & Asia

This page intentionally left blank.

Chapter 2

Safety Instructions

2.1 General Considerations



- All operators and service personnel must read and understand this manual before operating or servicing equipment.
- All maintenance and service on this equipment must be performed by trained technicians.



Read and adhere to the manual!







1. Read and follow these instructions.
Failure to do this could result in severe personal injury or death.
2. Keep the binding rules for accident prevention valid for your country and the place of installation. Also keep the approved qualified technical rules for safety-conscious and professional work.
3. Additional safety instructions and/ or symbols are located throughout this manual. They serve to warn maintenance personnel and operators about potentially hazardous situations.
4. Inspect the machine for unsafe conditions daily and replace all worn or defective parts.
5. Keep work area uncluttered and well lit. Remove all material or things not needed for the production from the workspace of the equipment!
6. All covers and guards must be in place before operating this equipment.
7. Subject to technical modifications without notice!
8. To ensure proper operation of the equipment, use specified electrical and/ or air supply sources.
9. Do not attempt to alter the design of the equipment unless written approval is received from ITW Dynatec.
10. Keep all manuals readily accessible at all times and refer to it often for the best performance from your equipment.

2.2 Warning Labels

1. Read and obey all of the warning labels, signs and caution statements on the equipment.
2. Do not remove or deface any of the warning labels, signs and caution statements on the equipment.
3. Replace any warning labels, signs and caution statements which have been removed or defaced. Replacements are available from ITW Dynatec.





2.3 Safety Symbols in this Manual

Mandatory signs



	General mandatory sign		Wear foot guard!
	Read and adhere to the documentation!		Wear protective gloves!
	Switch the unit voltage-free before working! Main switch OFF!		Wear protective clothing!
	Wear headgear, protective goggles and ear protection!		

Warning signs

NOTE: The dangers and risks exist if the corresponding instructions are not heeded and the precautionary measures are not taken!

	Caution, danger spot! This sign points to possible dangers for life and physical condition or to possible risks for machine and material or to possible risks for environment. The word “ DANGER ” in addition with this points to possible dangers of life The words “ WARNING ” and “ CAUTION ” in addition with this sign point to possible risks of injury. The word “ ADVICE ” in addition with this sign points to possible risks for machine, material or environment.		Danger, high voltage! This sign points to possible dangers for life and physical condition caused by electricity. Risk of injury, mortal danger!
			Caution, hot surface! This sign points to possible risks of burns. Risk of Burns!
			Caution, high pressure! This sign points to possible risks of injury caused by high pressure. Risk of injury!
			Caution, rotating rolls! This sign points to possible risks of injury caused by inrunning nip (at rolls). Risk of injury!

Prohibition signs

	Fire danger! Smoking prohibited!		Fire danger! Fire and open flames prohibited!
---	---	--	--

2.4 Safe Installation and Operation



Read and adhere to the manual!

1. Read this manual before applying electrical power to the equipment. Equipment may be damaged by incorrect electrical connections.
2. To avoid possible failure of hoses, make sure all hoses are routed to avoid kinking, tight radius turns (8" or less) and abrasive contact. Hot-melt hoses should not have prolonged contact with heat-absorbing surfaces such as cold floors or metal troughs. These heat-absorbing surfaces can alter adhesive flow and cause incorrect calibration. Hoses should never be covered with materials that prevent heat dissipation, such as insulation or sheathing. Hoses should be spaced apart from each other, not making direct contact.
3. Do not use adhesive that is dirty or that may be chemically contaminated. Doing so can cause system clogging and pump damage.
4. When adhesive hand-held applicators or other movable applicators are used, never point them at yourself or at any other person. Never leave a hand-held applicator's trigger unlocked when not actually in use.
5. Do not operate the hopper or other system components without adhesive for more than 15 minutes if the temperature is 150° C (300° F) or more. To do so will cause charring of the residual adhesive.
6. Never activate the heads, hand-held applicators and/ or other application devices until the adhesive's temperature is within the operating range. Severe damage could result to internal parts and seals.
7. Never attempt to lift or move the unit when there is molten adhesive in the system.
8. In case of an emergency or exceptional incident, press the emergency stop button in order to stop the unit quickly.
9. Use the unit only as it is intended to.
10. Never let the unit run unattended.
11. Operate the unit only in a faultless and fully functional condition. Check and make sure that all safety devices work in proper form!



Smoking, fire and open flames prohibited! Fire danger!

Make absolutely sure that there is no smoking and no fire being lit in the work area!

2.5 Explosion/ Fire Hazard

1. Never operate this unit in an explosive environment.
2. Use cleaning compounds recommended by ITW Dynatec or your adhesive supplier only.
3. Flash points of cleaning compounds vary according to their composition, so consult with your supplier to determine the maximum heating temperatures and safety precautions.

2.6 Choice of Adhesive



DANGER! HARMFUL FUMES!

Substance(s) being processed (e.g., melted, pumped, applied) by ITW equipment is at the discretion of the user and beyond ITW Dynatec's control. Any health effects or other safety-related concerns arising from the melting of those particular substances (e.g., hazardous fumes) is the responsibility of the user to identify and mitigate.

2.7 Eye Protection & Protective Clothing

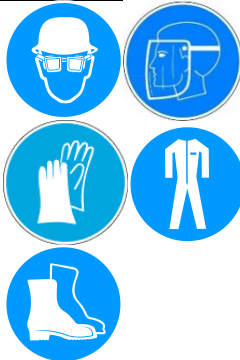

WARNING

EYE PROTECTION & PROTECTIVE CLOTHING REQUIRED

1. It is very important that you PROTECT YOUR EYES when working around hot melt adhesive equipment!
2. Wear a face shield conforming to ANSI Z87.1 or safety glasses with side shields which conform to ANSI Z87.1 or EN166.
3. Failure to wear a face shield or safety glasses could result in severe eye injury.
4. It is important to protect yourself from potential burns when working around hot melt adhesive equipment.
5. Wear heat-resistant protective gloves and long sleeved, protective clothing to prevent burns that could result from contact with hot material or hot components.
6. Always wear steel reinforced safety shoes.

2.8 Electrical



DANGER HIGH VOLTAGE

1. Dangerous voltages exist at several points in this equipment. To avoid personal injury, do not touch exposed connections and components while input power is on.
2. Disconnect, lockout and tag external electrical power before removing protective panels.
3. A secure connection to a reliable earth ground is essential for safe operation.
4. An electrical disconnect switch with lockout capability must be provided in the line ahead of the unit. Wiring used to supply electrical power should be installed by a qualified electrician.
5. Notify the maintenance personnel immediately, if cables are damaged. Provide for exchanging the defective components immediately.

2.9 Lockout/ Tagout



Switch the unit voltage-free before working! Main switch OFF!

1. Follow OSHA 1910.147 (Lockout/ Tagout Regulation) for equipment's lockout procedures and other important lockout/tagout guidelines.
2. Be familiar with all lockout sources on the equipment.
3. Even after the equipment has been locked out, there may be stored energy in the application system, particularly in the capacitors within the panel box. To ensure that all stored energy is relieved, wait at least one minute after removing power before servicing electrical capacitors.

2.10 High Temperatures



WARNING HOT SURFACE

1. Severe burns can occur if unprotected skin comes in contact with molten adhesive or hot application system parts.
2. Face shields (preferred) or safety glasses (for minimum protection), heat-resistant protective gloves and long-sleeved clothing must be worn whenever working with or around adhesive application systems.

2.11 High Pressure



WARNING HIGH PRESSURE PRESENT

1. To avoid personal injury, do not operate the equipment without all covers, panels and safety guards properly installed.
2. To prevent serious injury from molten adhesive under pressure when servicing the equipment, disengage the pumps and relieve the adhesive system's hydraulic pressure (i.e. trigger the heads, hand-held applicators, and/or other application devices into a waste container) before opening any hydraulic fittings or connections.
3. IMPORTANT NOTE: Even when a system's pressure gauge reads "0" psi, residual pressure and trapped air can remain within it causing hot adhesive and pressure to escape without warning when a filter cap or a hose or hydraulic connection is loosened or removed. For this reason, always wear eye protection and protective clothing.
4. Either of the two High Pressure symbols shown may be used on ITW Dynatec equipment.
5. Keep the given operating pressure.
6. Notify the maintenance personnel immediately, if hoses or components are damaged. Provide for exchanging the defective components immediately.

2.12 Protective Covers



WARNING **DO NOT OPERATE WITHOUT GUARDS IN PLACE**

1. Keep all guards in place!
2. To avoid personal injury, do not operate the application system without all covers, panels and safety guards properly installed.
3. Never get your extremities and/or objects into the danger area of the unit. Keep your hands away from running parts of the unit (pumps, motors, rolls or others).

2.13 Servicing, maintenance

1. Only trained and qualified personnel are to operate and service this equipment.
2. Before any service work disconnect the external power supply and the pressure air supply!
3. Never service or clean equipment while it is in motion. Shut off the equipment and lock out all input power at the source before attempting any maintenance.
4. Follow the maintenance and service instructions in the manual.
5. Keep the maintenance rates given in this documentation!
6. Any defects in the equipment that impact safe operation have to be repaired immediately.
7. Check screws that have been loosened during the repair or maintenance, if they are tight again.
8. Replace the air hoses in preventive maintenance regularly, even if they have got no viewable damages! Adhere to the manufacturers` instructions!
9. Never clean control cabinets or other houses of electrical equipment with a jet of water!
10. Adhere to the current safety data sheet of the manufacturer when using hazardous materials (cleaning agents, etc.)!

2.14 Cleaning Recommendation

- Filters are disposable and need to be replaced regularly. DO NOT boil in mineral oil, solvents or water; the sealant used in filter assembly may become brittle and very likely disintegrate when boiled.
- When cleaning other components in mineral oil, remove all non-metallic items (O-rings, seals, filter cartridge, etc.) away from chemicals before components are subjected to hot mineral oil cleaning.
- If there is not a specific rebuild kit available or directions on how to clean a part, please treat it as a replacement item and do not attempt to clean/rebuild.

2.15 Secure transport

1. Examine the entire unit immediately after receipt, if it has been delivered in perfect condition.
2. Let damages in transit certify by the carrier and announce them immediately to the ITW Dynatec.
3. Use only lifting devices that are suitable for the weight and the dimensions of the equipment (see drawing of the equipment).
4. The unit has to be transported upright and horizontally!
5. The unit has to cool down to room temperature before packaged and transported.

2.16 Treatment for Burns from Hot Melt Adhesives

Measures after being burned:

1. Burns caused by hot melt adhesive must be treated at a burn center. Provide the burn center's staff a copy of the adhesive's M.S.D.S. to expedite treatment.
2. Cool burnt parts immediately!
3. Do not remove adhesive forcibly from the skin!
4. Care should be used when working with hot melt adhesives in the molten state. Because they rapidly solidify, they present a unique hazard. Even when first solidified, they are still hot and can cause severe burns.
5. When working near a hot melt application system, always wear safety shoes, heat-resistant protective gloves, safety goggles and protective clothes that cover all vulnerable parts of the body.
6. Always have first-aid information and supplies available.
7. Call a physician and/or an emergency medical technician immediately. Let the burns medicate by a medic immediately.

2.17 Measures in case of fire

1. Please heed that not covered hot parts of the engine and molten hot melt may cause heavy burns. Risk of burns!
2. Work very carefully with molten hot melt. Keep in mind, that already jelled hot melt can be very hot, too.
3. When working near a hot melt application system, always wear safety shoes, heat-resistant protective gloves, safety goggles and protective clothes that cover all vulnerable parts of the body!

Measures in case of fire:

Wear safety shoes, heat-resistant protective gloves, safety goggles and protective clothes that cover all vulnerable parts of the body.

Firefighting - burning hot melt:

Please keep attention to the safety data sheet given by the adhesive manufacturer.

	<h3>EXTINGUISH FIRE</h3>
	<p><i>Appropriate extinguishing agents:</i> Foam extinguisher, Dry powder, Spray, Carbon dioxide (CO₂), Dry sand.</p>
	<p><i>For safety reasons not appropriate extinguishing agents: None.</i></p>
	<p>Firefighting - burning electrical equipment:</p>
	<p><i>Appropriate extinguishing agents:</i> Carbon dioxide (CO₂), Dry powder.</p>

2.18 Keep attention to environmental protection standards

	<p>1. When working on or with the unit, the legal obligations for waste avoidance and the duly recycling / disposals have to be fulfilled.</p>
	<p>2. Keep attention, that during installations, repairs or maintenance matters hazardous to water, like adhesive / adhesive scrap, lubricating grease or oil, hydraulic oil, coolant and cleaner containing solvent do not pollute the ground or get into the canalization!</p>
	<p>3. These matters have to be caught, kept, transported and disposed in appropriate reservoirs!</p>
	<p>4. Dispose these matters according to the international, national and regional regulations.</p>

Chapter 3

Description and Technical Specs

3.1 Applicable Safety Regulations

3.1.1 Intended Use

The Dynamelt M Adhesive Melter may be used only to melt and supply suitable materials, e.g. adhesives. When in doubt, seek permission from ITW Dynatec.



If the unit is not used in accordance with this regulation, a safe operation cannot be guaranteed.

The operator - and not ITW Dynatec - is liable for all personal injury or property damages resulting from unintended use!



Intended use includes, that you

- read this documentation,
- heed all given warnings and safety instructions, and
- do all maintenance within the given maintenance rates.

Any other use is considered to be unintended.

3.1.2 Unintended Use, Examples

The Melter may not be used under the following conditions:

- In defective condition.
- In a potentially explosive atmosphere.
- With unsuitable operating/processing materials.
- When the values stated under Specifications are not complied with.

The Melter may not be used to process the following materials:

- Toxic, explosive and easily flammable materials.
- Erosive and corrosive materials.
- Food products.

3.1.3 Residual Risks

In the design of the Melter, every measure was taken to protect personnel from potential danger. However, some residual risks cannot be avoided.

Personnel should be aware of the following:



- Risk of burns from hot material.
- Risk of burns from hot Melter's components.
- Risk of burns when conducting maintenance and repair work for which the system must be heated up.



- Risk of burns when attaching and removing heated hoses.
- Material fumes can be hazardous. Avoid inhalation. If necessary, exhaust material vapors and/or provide sufficient ventilation of the location of the system.
- Risk of pinching parts of the body at running parts of the unit (pumps, motors, rolls or others).
- The safety valves may malfunction due to hardened or charred material.

3.1.4 Technical changes

Any kind of technical changes having impact to the security or the operational liability of the system should only be done by written agreement of ITW Dynatec. Suchlike changes made without given a corresponding written agreement will lead to immediate exclusion of liability granted by ITW Dynatec for all direct and indirect subsequent damages.

3.1.5 Using foreign components

ITW Dynatec takes no responsibility for consequential damages caused by using foreign components or controllers that have not been provided or installed by ITW Dynatec.

ITW Dynatec does not guarantee that foreign components or controllers used by the operating company are compatible to the ITW Dynatec-system.

3.1.6 Setting-up operation

We recommend asking for an ITW Dynatec-service technician for the setting-up operation, to ensure a functioning system. Let yourself and the people working with or working on the system be introduced to the system on this occasion.
ITW Dynatec takes no responsibility for damages or faults caused by any untrained personal.

3.2 Description of Dynamelt M Melt & Supply Unit

3.2.1 Description

The Dynamelt M Series Adhesive Melt and Supply Units (Melters, ASU) are computer-controlled hot-melt supply units designed on metric standards. Their control panels, with choice of display languages, provide comparative data of all setpoints, motors, etc. on a few convenient, comprehensive display screens.

The Dynamelt M Series Melters are available in three cabinet sizes and offer four hopper sizes. The Dynamelt M210 uses a microprocessor temperature control to closely control the temperature of hotmelt adhesive for up to 12 hoses and 12 heads. Temperature setpoints are operator-selected for up to 48 zones and the system automatically provides warnings and alarms for operator errors and system malfunctions.

A variety of customer-selected devices may be integrated into the HMI utilizing VNC desktop sharing. An optional XIO module allows programmable I/O for custom applications. Up to ten units may be controlled remotely by each touch panel.

The Dynamelt/ DynaControl system provides accurate, proportionate temperature control for the hopper, hoses and applicators. Sequential heating delays may be programmed for turn-on of the hoses and heads. A "standby" temperature may be programmed so that the temperature zones can be maintained at a lower temperature when the Melter is not in active use, enabling rapid return to normal operation. The Scheduler allows programmable automatic startup and shutdown of the Melter throughout the workweek.

With these flexible temperature programming features, the Dynamelt system increases adhesive life by eliminating prolonged high adhesive temperatures. It reduces energy consumption and brings the system up to normal operating temperatures in the shortest possible time.

A four-layered, shielded CPU board protects the microprocessor from external interference. The temperature control can interlock the parent machine with preselected adhesive temperatures so that production automatically begins when adhesive temperatures are correct for the application. All system temperature values can easily and quickly be programmed.

Digital readout of system conditions is provided. A security code can restrict access to system programming and parameters. The CPU monitors the electronic circuitry and provides alarms for error conditions.

The Melter uses an extremely dependable gear pump(s) to assure a smoother and higher precision flow. The single or dual pumps are driven by individual drives.

The Melter's Teflon-coated hopper accepts adhesive in all popular forms, including pellets, slugs and blocks. The Melter can accommodate air-actuated automatic applicators (heads), electric applicators, hand-held applicators and/or special applicators. Options available include pressure gauge, additional drop-in grids, dual hopper, digital pressure readout, pneumatic pressure relief valves and adhesive level control. The M210 is also available in a high flow model.

3.2.2 Specifications

Environmental:

Storage/ shipping temperature	-40°C to 70°C (-40°F to 158°F)
Ambient service temperature	-7°C to 50°C (20°F to 122°F)
Noise emission.....	< 60 dbA (at 1 meter/ 39 in)

Physical:

Dimensions	see dimensional layouts on following pages
Number of hoses/ applicators	1 to 12
Number of return hoses or auxiliary zones	1 to 12
Number of hopper temperature zones.....	1 to 2 (add 1 for optional drop-in grid)
Number of pumps/ motors	1 to 6
Number of standard drop-in grids	3
Number of (optional) drop-in grids	3
Gear pumps	2.92 cc/rev standard
Enclosure	styled, durable metal, dust and splatter resistant
Hose connections	universal 15-pin Amphenol connectors at Melter wrench-secured fluid fittings (#6 JIC)
Hopper (tank) capacity.....	M210 = 210 kg (420 lbs)
Hopper lid openings	Opening dimensions of full lid = 214 mm x 271 mm Opening dimensions of split lid (for level sensor mounting) = approximate 99 mm x 271 mm
Hopper construction.....	machined welded aluminum, Teflon impregnated
Hopper coating.....	ceramic nano-composite
Filtration	hopper bottom screen, large pleated pump outlet filter
Weight of base unit, empty	M210 = from 1043 kg (2300 lbs)
Adhesive form	accepts most forms

Electrical:

Supply voltage	240 VAC/ 3p/ 50-60 Hz 400 VAC/ 3p ("Wye", "Y" or 5-wire connection)/ 50-60 Hz
Minimum supply amperes	see circuit breaker size
Power consumption, hopper	15,000 W
Power consumption, 3 drop-in-grids	7,500 W
Power consumption, 3 additional drop-in-grids (optional)	7,500 W
Hopper heater type	cast-in tubular
Temperature control.....	microprocessor-based PID
Temperature sensors.....	100 Ohm Platinum RTD, standard
Electrical connectors.....	durable, latching connectors
Motor	1/2 hp, alternating current TEFC* motor, direct drive, vertical orientation, right angle gearbox
Maximum recommended pump speed	90 revolutions per minute

TEFC* = totally enclosed, fan cooled

Performance:

Maximum operating temperatures	218°C (425°F)
Adhesive temperature control range.....	40°C to 218°C (100°F to 425°F)
Standby adhesive temperature range.....	up to 80°C (150°F) lower than setpoint
Hopper ready adhesive temperature deviation (factory set/ field adjustable) . ± 20°C (36°F) from setpoint	
Over-temperature cutoff for hopper	218°C (425°F)
Adhesive viscosity	500 to 50,000 centipoise
Warm-up time, full hopper	approximately 30 minutes
Typical adhesive melt rate (depends on adhesive used)	up to 145 kg/h (319 lb/h)
Adhesive pressure	up to 68 bar (1000 psi) maximum

DynaControl V6 Temperature Controller:

Controller Architecture	max. 48 zones, 16 per RTD-module, 5 per Power-board
Display type.....	Color Touch Screen
Temperature control zones (M210).....	48 maximum with solid state relays
Solid state relay	24 VDC
Line speed inputs.....	1 to 6

Other

Display languages.....	English, French, German, Spanish, Swedish, Italian, Japanese, Chinese, Portuguese, Dutch and Hungarian
Operator interface	multi-zone, liquid crystal touch screen display with alpha/numeric keyboard and function keys
Temperature stand-by.....	yes
High and low temperature alarms	yes
Ready interlock	yes
Password protection	yes
Sequential heating	yes (hopper, hose, head staged heating)
Sensor open alarm.....	yes
PLC interface	yes
Line speed tracking.....	yes
Seven-day scheduler	yes
High-temp capable.....	yes
CE approval	yes, only 400V AC

3.2.3 Dimensions

Dimensions are expressed as “mm [inch]”.

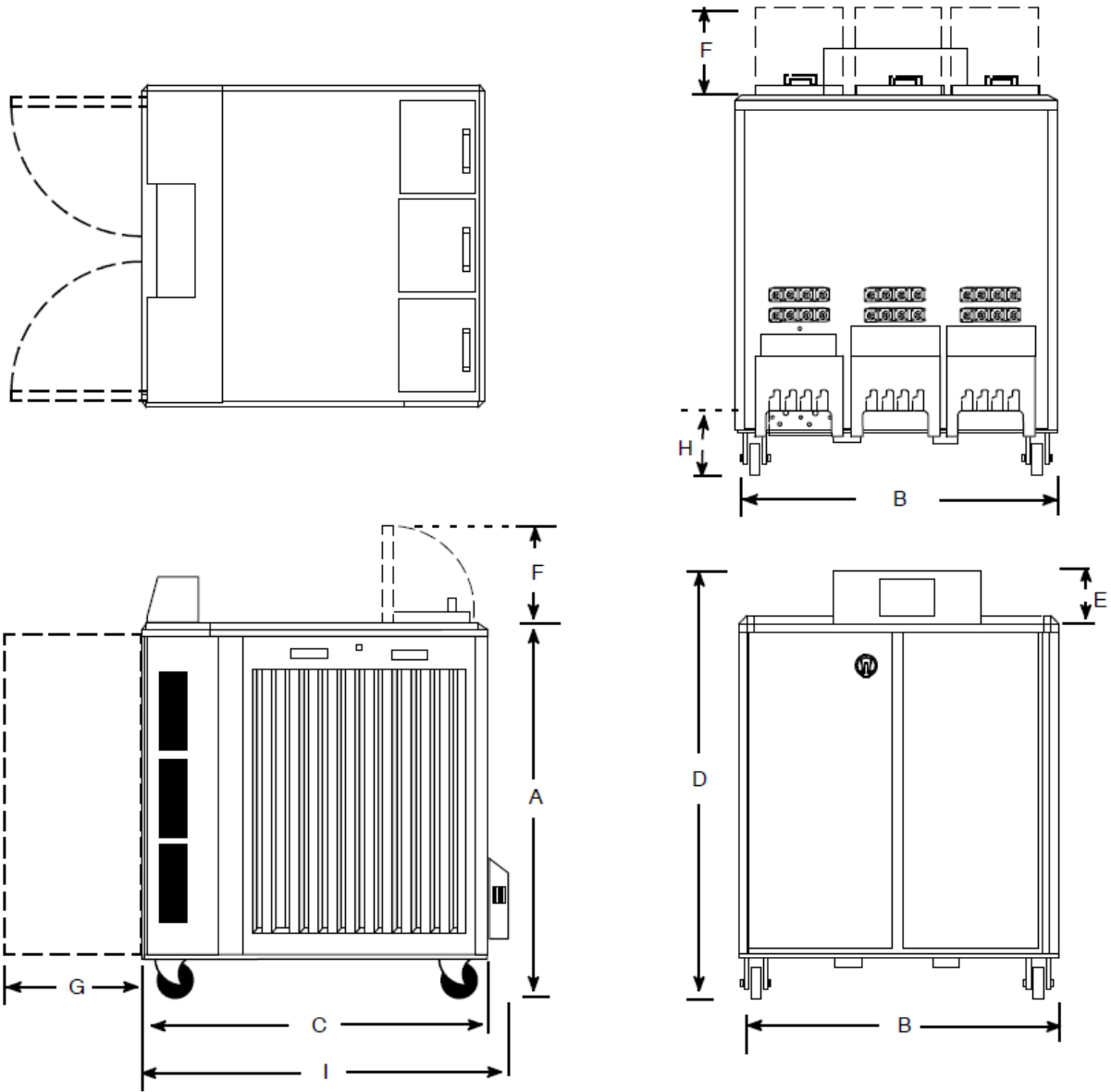

Dimensions	A	B	C	D	E	F	G	H	I
mm	1506.4	1227.4	1301.6	1622.3	177.8	342.9	610	320.68	1377.7
inches	59.31	48.32	51.24	63.87	7	13.5	24	12.625	54.24

Installation Dimensions: DYNAMELT M210

3.2.4 Total System Wattage Capacity

Available Wattage:

- No hose, applicator or auxiliary zone shall exceed 2400W.
- Hose and its corresponding applicator together shall not exceed 2400W.
- Total wattage for hoses, applicators and auxiliary zones shall not exceed the limits listed below.

Wattage	M210
Hopper + Filter manifold	18000 W
Premelt Grids	7500 W
Optional Drop-in Grid	7500 W
Up to 12 Hose Zones	up to 14400 W
Up to 12 Applicator Zones	up to 14400 W
Up to 12 AUX Zones	up to 28800 W
Maximum System Wattage*:	62,000 W

***Note:** Maximum System Wattage is lower than total combined wattage of all potential zones.

This is done intentionally to reduce the required Amperage of the service supplied by the end user.

3.2.5 Main Circuit Breaker Determination

Main circuit breakers vary depending on each unit's system configuration. ITW Dynatec typically determines the main circuit breaker by the mains load for a system. If a customer later modifies his system (by adding heads, hoses, auxiliary outputs, etc.), the main breaker may need to be upgraded to reflect the increase in load.

To determine your existing main circuit breaker, first determine if the Melter has been modified and the breaker upgraded accordingly. If not, and the breaker is original to the Melter, you will find the main circuit breaker listed in the Panel Box Assembly (PBA) section of the indented bill of materials inserted at the back of this manual. The main circuit breaker is the largest amperage circuit breaker listed in that bill of materials.

3.2.6 Definition of Code

Melter Code: M XXXX V6 X XXX XXX X DX FX- XXX...

Example: M 210S V6 N GASZLS 2 D2 F2- DN

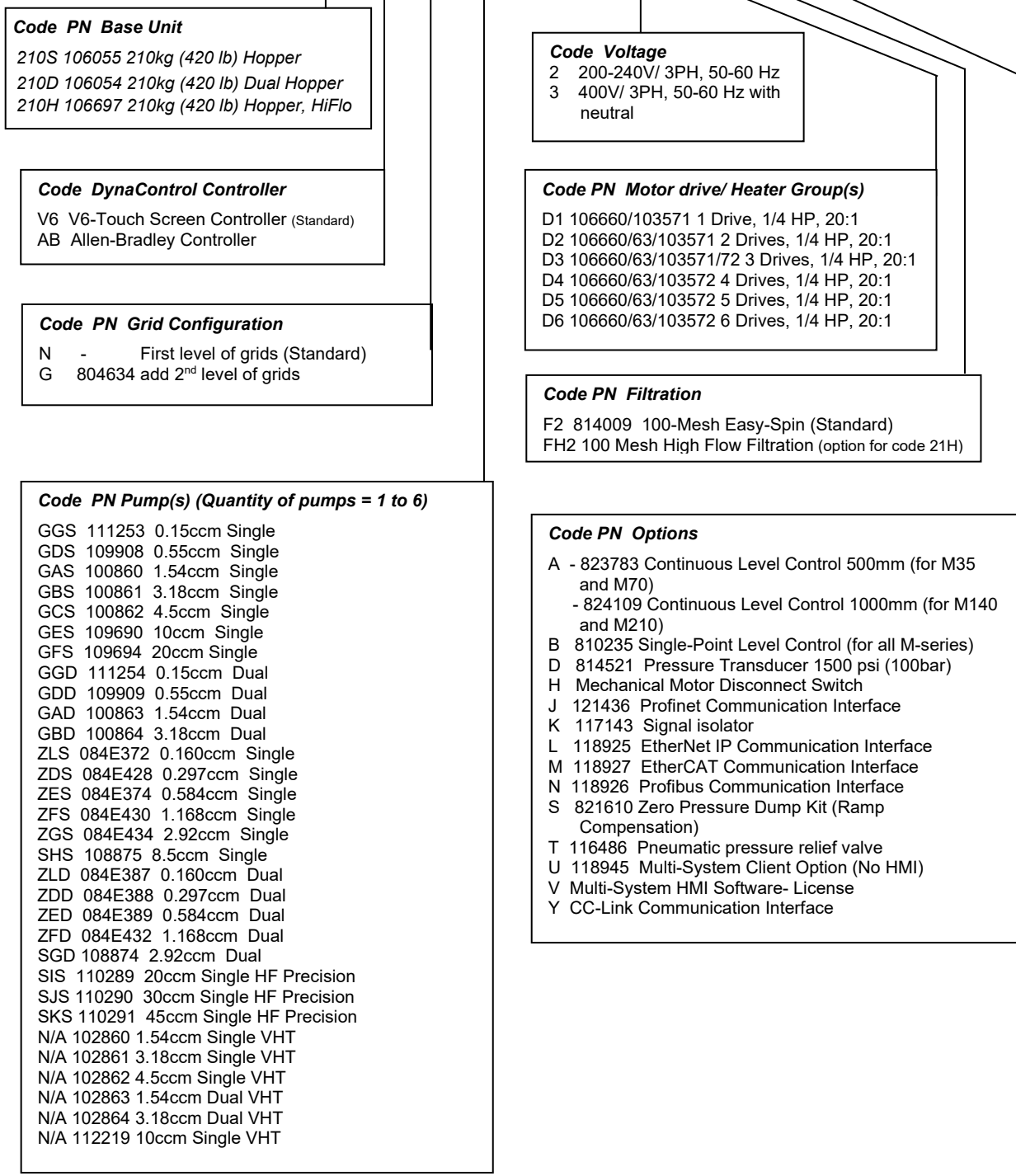

Melter codes are typically compiled without spaces between categories.

The example shown above would be recorded as M210SV6NGASZLS2D2F2-DN

Chapter 4 Installation



CAUTION

- Before installation, please read this documentation carefully.
- Pay attention to all the installation and connecting advices.
- Heed all safety instructions mentioned in Chapter 2.
- All installation procedures must be performed by qualified, trained technicians.

4.1 Placing the Dynamelt M Melter

Place the Melter on flat surfaces. The main electrical power and the serial communication connections come in from below the unit and connect under the DynaControl keypad, so access is needed there.



DANGER – INSTALL ON FLAT SURFACE

Typical equipment configuration includes wheels and brakes, which should be engaged whenever the equipment is not being transported.

DO NOT install equipment on a sloped surface. Transportation of equipment over a sloped surface presents an increased risk of injury in the event of uncontrolled rolling.

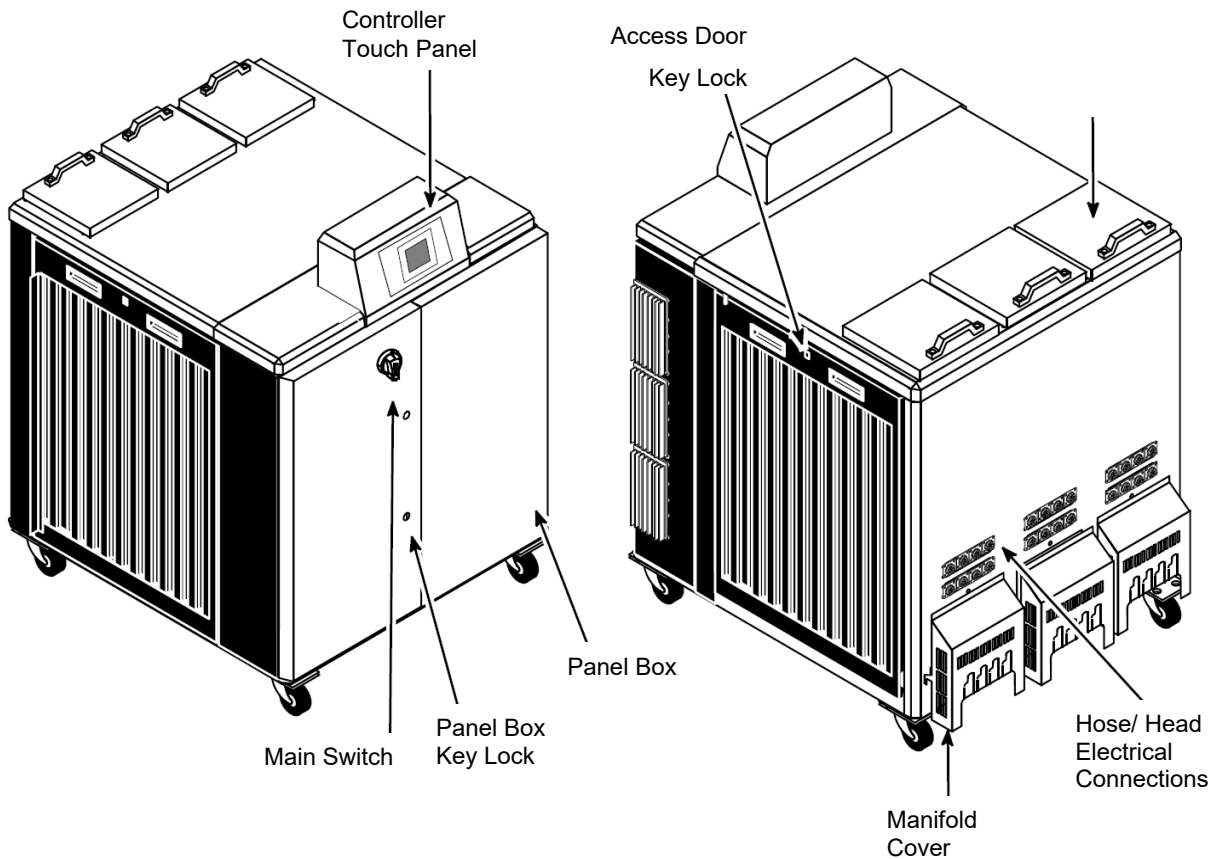

DYNAMELT M210 DCL Melter

4.2 To Open/ Close Panel Box Door

1. With the key supplied, unlock the panel box door.
2. Pull door open.
3. *To close*: Hold door closed while turning main disconnect switch clockwise to "ON".
4. Lock the panel box door with the key.
5. Be sure panel box door is closed securely before operating machine.

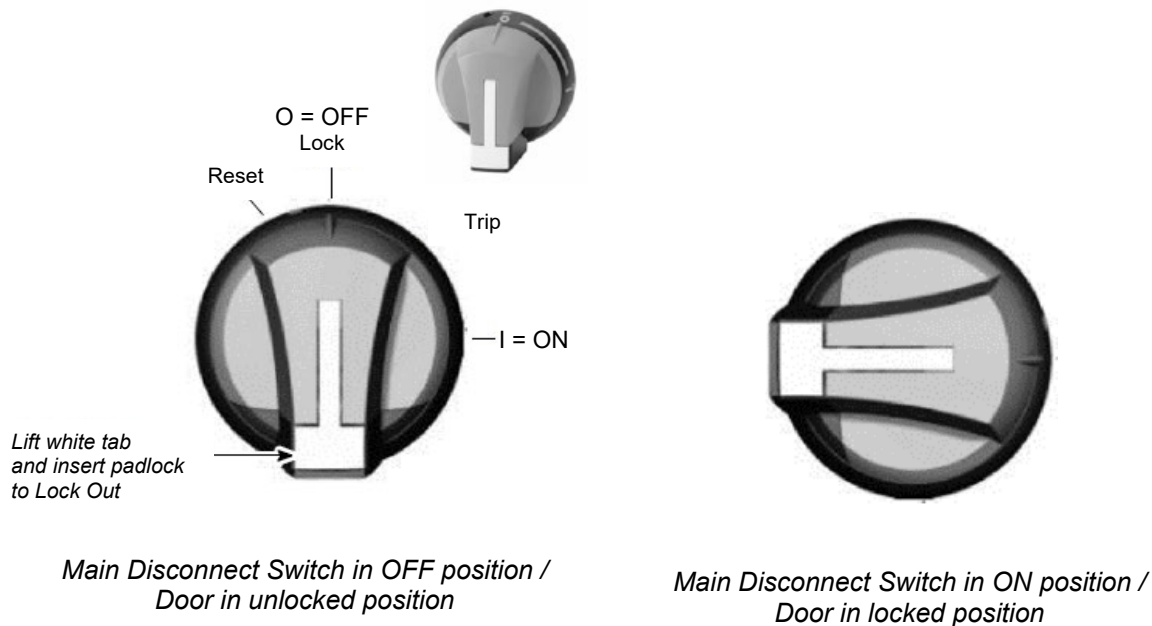

4.3 Installation

After the Melter has been properly positioned, the following general sequence should be followed for installation:

1. Make sure that incoming line power to the Melter and that the unit's main disconnect switch are turned OFF.



DANGER – HIGH VOLTAGE

**Disconnect and lock out input power to the application system, using the safety lock out tab illustrated above, before starting any installation procedures.
Make sure there is no electrical power on the leads you will be connecting.**

2. Within the panel box assembly: connect 3 electrical leads with the appropriate voltage to the main circuit breaker and connect one electrical lead to the ground (PE) terminal (see diagram following).

400V Melters only: In addition to above, connect one lead to the neutral terminal.





CAUTION: Grounding conductors never carry electrical current. The use of a neutral conducting wire as earth ground is incorrect and may cause damage to the controller.

- At installation, the customer must make the following terminal connections into the Melter's main power (ON/OFF) switch and modules. The modules do not need to be removed from the Melter in order to make connections.

Refer to the detailed layout drawings of the components in Ch. 7 and/or the schematics in Ch. 11, if needed.

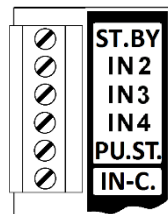
4.4 Customer Terminal Connections

Terminal	Circuit	Location
Required connections for 240VAC, 3 PH Delta Melter:		
--	Input Power from Main Power 240VAC	Main ON/OFF Switch / L1, L2, L3
PE	Ground	Ground Lug
Required connections for 400VAC, 3 phase, WYE Melter:		
--	Input Power from Main Power, 400 VAC	Main ON/OFF Switch/ L1, L2, L3
N	Neutral, 400 VAC	Terminal on Main Switch
PE	Ground	Ground Lug
Non-essential connections; connect if feature is installed:		
RELAY OUTPUT 1	Ready Output Signal (contact closes when ready)	Terminal Block
RELAY OUTPUT 2	Alarm Output Signal (contact opens when alarm)	Terminal Block
RELAY OUTPUT 3	Hopper Low Level Signal (contact closes when glue level is low)	Terminal Block
ST.BY IN2 IN3 IN4 PU.ST. IN-C.	Standby Input Recipe Selection 1 Recipe Selection 2 Reserved External Pump Start/Stop (activate to start pump) Common for Inputs	V6 BASE Module, bottom side: 
LINE COM	Line Speed Tracking Voltage (0-10V)	V6 BASE Module, bottom side: 
G+l or L+l	Line Speed Tracking Signal with Signal Isolator (option)	Terminal Block

4.5 Customer Signal Exchange Interfaces

Signal	M-Unit Terminal Block
Motor Start 1	EN1A/EN1B
Motor Start 2	EN2A/EN2B
Motor Start 3	EN3A/EN3B
Motor Start 4	EN4A/EN4B
External Standby	STBY1/STBY2
Line Speed 0-10V (Motor 1/Master)	SP1A/SP1B
Line Speed 0-10V (Motor 2)	SPR/SPRE (Reserve not connected)
Line Speed 0-10V (Motor 3)	SPR/SPRE (Reserve not connected)
Line Speed 0-10V (Motor 4)	SPR/SPRE (Reserve not connected)
Line Speed 0-10V (Motor 5)	SPR/SPRE (Reserve not connected)
Line Speed 0-10V (Motor 6)	SPR/SPRE (Reserve not connected)
Ready	RDY1/RDY2
Alarm	AL1/AL2
Level Control (Low Level)	LL1/LL2

4.6 Module & Printed Circuit Board Location Diagram

The V6 modules and printed circuit boards (PCBs) are located within the main panel box assembly. All units have layouts similar to the one shown below.

Note for Dual (split) Hopper Models: there are two V6 Module racks in the panel box. The V6 Base Module #1 controls Hopper #1 and the V6 Base Module #2 controls Hopper #2.

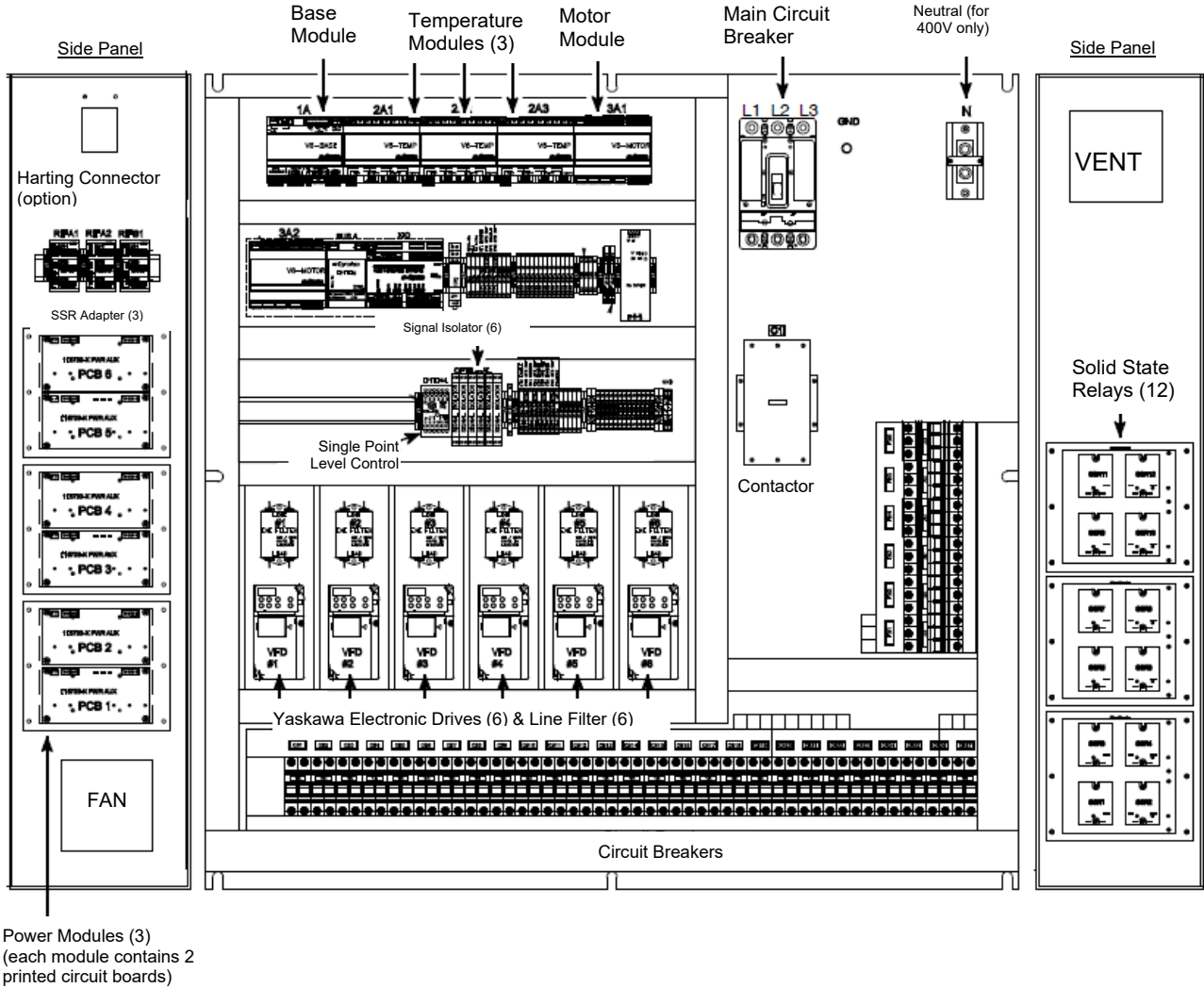

Typical Panel Box Layout with Options (Single Hopper model shown)

4. The adhesive hoses are connected at the rear cover (see illustration on next page). Each hose is connected at both an adhesive port and an electrical connect. Make your electrical hose connections at the numbered connects above the filter manifolds. Route hoses so that there is at least an eight-inch radius at any bend. Do not hang hoses without proper support. Do not crimp, clamp, squeeze or tie hoses.

Two feed hose adhesive ports are located near the center of each filter manifold. When making hose connections, use the numbered guides shown on the illustration to coordinate; i.e. when using one hose, make your hookup to electrical connection #F1 and adhesive port #F1. When using two heads/ hoses, hookup hose/ head #1 to electrical connection #F1 and adhesive port #F1, then hookup hose/ head #2 to electrical connection #F2 and adhesive port #F2, etc.

5. Auxiliary electrical connects (A1, A2, etc.) are provided for customer's use, as needed.
6. Connect (optional) PSI transducers at the PSI ports labeled on the filter manifold. Position them from left to right across the manifolds as shown in the lower illustration on page 3-6. Transducers measuring adhesive pressure before it enters the filter use the ports stamped "Pre-PSI" and transducers measuring pressure after the filter use the ports stamped "Post PSI". Transducers must be wired into the BASE/Motor-Module.

Units not using transducers may use either a PSI port or a feed hose port to mount a (optional) pressure gauge. If all ports are in use, the pressure gauge may be installed in line with a hose.

Refer to the hose and applicator manuals for further details on these items.

4.7 Electrical Connections and Filter Manifold Arrangement for maximum Head/ Hose Configuration

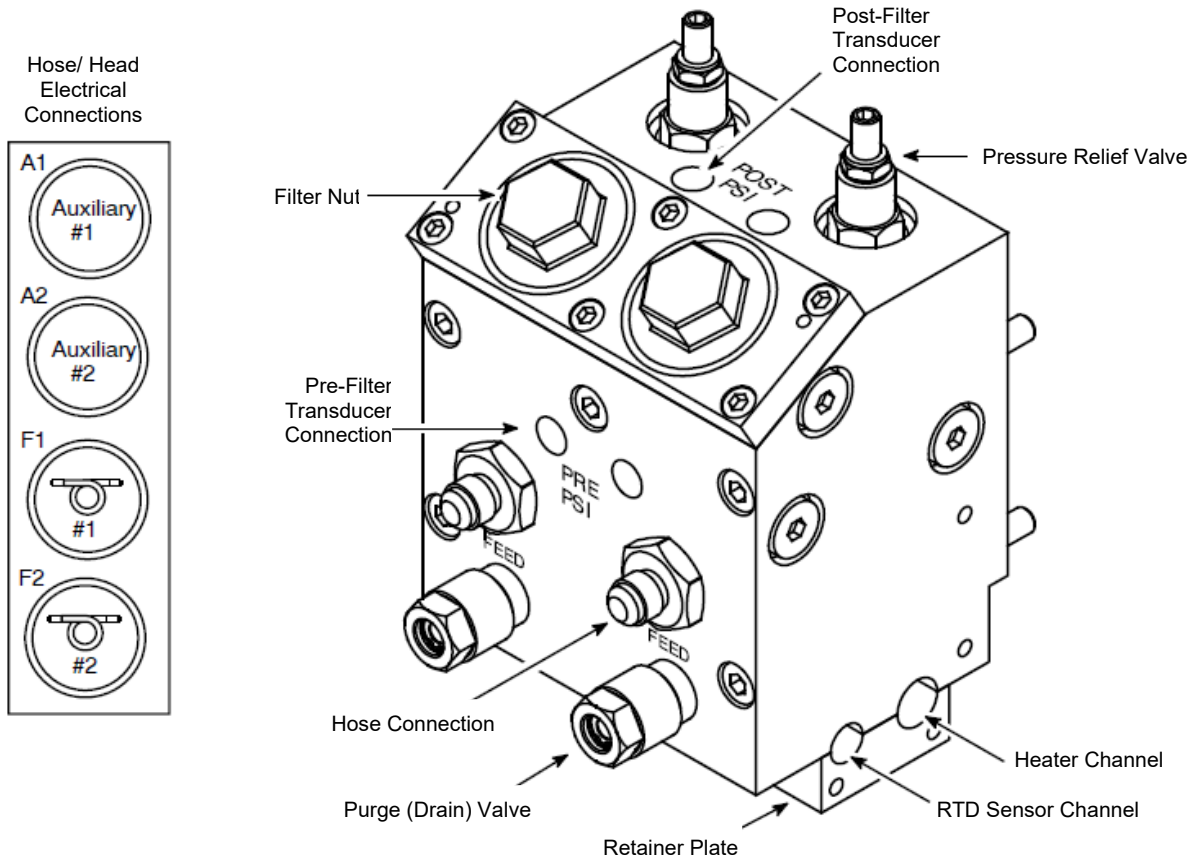

Hose/ Head Electrical and Adhesive Connections

Electrical Connections F1 thru F12 are for Head/ Hoses
Electrical Connections A1 thru A12 are for Auxiliaries

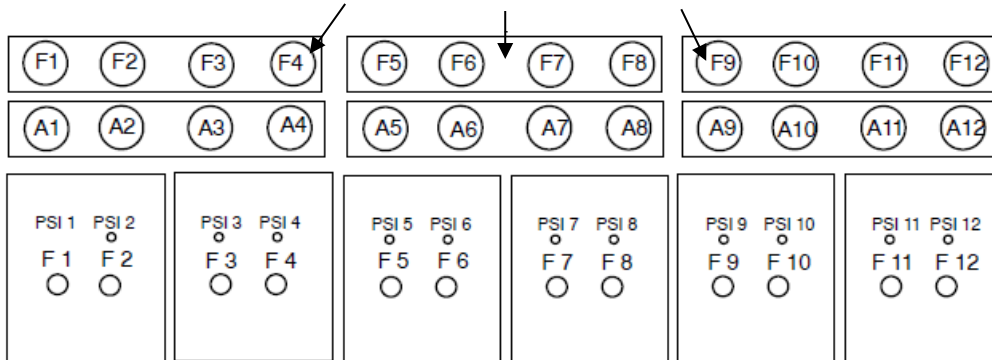

Adhesive supplied by motor/pump #1 Adhesive supplied by motor/pump #2 Adhesive supplied by motor/pump #3 Adhesive supplied by motor/pump #4 Adhesive supplied by motor/pump #5 Adhesive supplied by motor/pump #6

Up to six Filter manifolds with up to 24 Adhesive Ports

Note:

Always connect Feed Hose #1 (F1) to Feed Electrical Connect #1 (F1), Auxiliary #1 (A1) to Auxiliary Electrical Connect #1 (A1), etc. as described on previous page.

Dynamelt M210: Electrical Connection and Filter Manifold Arrangement for Maximum Head/ Hose Configuration

4.8 Quality of Compressed Air



CAUTION

- In any case, the air has to be clean and dry!
- The min. requirement for compressed air supply to solenoids to control automatic Applicators is ISO 8573-1:2010 **class 2:4:3**.
We recommend installing the ITW Dynatec's Air Control Kit PN 100055.
- The min. requirement for compressed air supply to solenoids to control Adhesive Supply Unit is ISO 8573-1:2010 **class 7:4:3**.

Compressed air quality classes according to ISO 8573-1:2010 **class 7:4:3**:

ISO 8573-1: 2010	Solid particles			Mass concentration mg/m ³	Water		Oil
	Maximum number of particles per m ³				Vapor pressure dew point °C	Liquid g/m ³	
Class	0.1-0.5 µm	0.5-1 µm	1-5 µm				
0	As stipulated by the equipment user, stricter requirements than class 1.						
1	≤ 20,000	≤ 400	≤ 10	-	≤ -70	-	0.01
2	≤ 400,000	≤ 6,000	≤ 100	-	≤ -40	-	0.1
3	-	≤ 90,000	≤ 1,000	-	≤ -20	-	1
4	-	-	≤ 10,000	-	≤ +3	-	5
5	-	-	≤ 100,000	-	≤ +7	-	-
6	-	-	-	≤ 5	≤ +10	-	-
7	-	-	-	5-10	-	≤ 0.5	-
8	-	-	-	-	-	0.5 - 5	-
9	-	-	-	-	-	5 - 10	-
X	-	-	-	> 10	-	> 10	> 10

4.9 Adding Adhesive

The adhesive level in the melt tank should be maintained at 13mm to 100mm (1/2" to 4") from the top of the hopper. Where applications demand a high output volume of adhesive, add small amounts of adhesive frequently. Adding large amounts of adhesive to an almost empty hopper will lower the temperature of the adhesive in the hopper and may cause the Melter to fall below its READY setpoint.

4.10 Changing the Adhesive Formula

If a different adhesive formulation from the one being currently used is needed, the system will have to be flushed if the two formulations are incompatible. See Chapter 6 of this manual for the proper flushing procedure. When in doubt about adhesive compatibility, flush your system.

4.11 Field Installation of Controller Options

Customers who choose to modify their adhesive supply unit with ITW Dynatec manufactured options should assure that only qualified technicians perform such installations. The installation of options that require specific procedures and/ or calibration are outlined in this chapter.

Before controller options are installed, always turn the controller's main power switch OFF. In most cases, turning the controller OFF will assure that the controller will retain its programmed parameters and configuration. Re-booting is not necessary.

4.12 Adjusting the Pressure Relief Valve

The function of the pressure relief valve is to protect the gear pump(s) and the pump drive components from overload and to protect other components from potentially damaging pressure levels. The system will allow pressures up to 1000 psi (70 bar), however, typical factory settings are 500 psi (35 bar).



WARNING! HIGH PRESSURE, HOT ADHESIVE!

NOTE: The following procedure will require the hot melt adhesive to be at a high temperature and the application system to have substantial pressure. Safety glasses, insulated gloves and long-sleeved protective clothing must be worn to prevent the possibility of serious injury from the molten adhesive. Refer to Chapter 2 and the section entitled “SAFETY PRECAUTIONS” for further details and First Aid information.

To Adjust Pressure Relief:

Note: This adjustment should be done with a melt pressure gauge or a pressure transducer installed. Failure to use proper equipment can result in excessive pressure levels.

The pressure relief valves are located on the filter manifolds, which are located under the rear manifold cover(s), near where the hoses connect to the Melter.

1. Turn the application system ON and raise the temperatures of all components to normal operating temperatures.

Note: Position a heat-resistant bucket or other waste receptacle under the applicator(s) so that adhesive will be collected during the adjustment procedure.

2. At the controller, set the motor speed to “0” so that the gear motor is not turning.

Note: If using a single pump or if using a dual pump with both output streams combined into one, adjust one of the pressure relief valves fully clockwise to close it off and use the other valve to adjust that pump’s pressure setting.

If using a dual pump with separate glue streams, set the pressure of each stream with its respective pressure relief valve.

Reference Note #7 on the Filter manifold drawing (Ch.10) regarding the plug that separates the two pressure chambers, if using a dual pump. This plug must be removed if combining dual streams into one or if using a single output pump.

3. The pressure relief valve’s adjustment screw is at the top of the valve (see diagram). Turn the adjustment screw counterclockwise until it stops.
4. At the controller, turn the motor ON to its maximum operating speed.

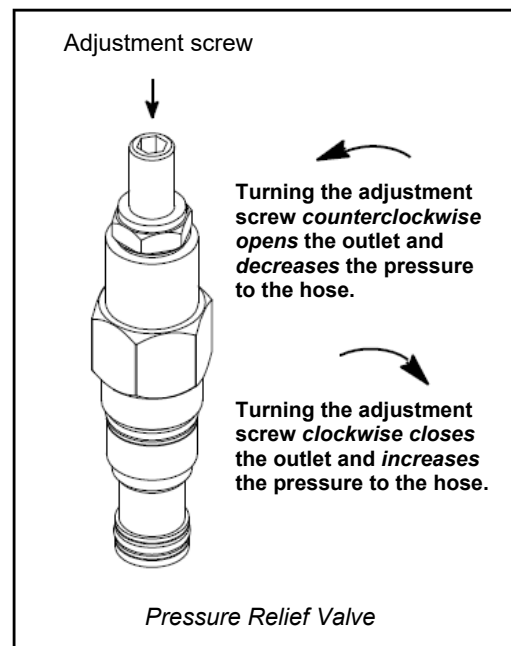

5. Actuate (open) the valves on the applicator(s) in order to fill them with adhesive and purge air from the system.
6. Close the valves (those opened in the last step) to stop the flow of adhesive.
7. Using a wrench, turn the adjustment screw clockwise to increase the pressure to the applicator(s).



CAUTION: Approach desired pressure with caution. Be aware that the higher the adjusted pressure, the more sensitive the adjustment is (i.e., at higher pressures, smaller adjustments to the screw will make larger changes to actual pressure).

8. After desired pressure is achieved, stop turning the adjustment screw.
9. While the motor is operating at maximum speed and the applicator's solenoids are activated, observe the adhesive flow from the applicator(s).
10. Reduce the motor speed, in increments of about 10%, until the adhesive flow begins to decrease.

Note: Though the speed of the motor is reduced, there will be no change in the amount of adhesive flow coming out of the applicator. This is because the pressure relief is designed to allow only a maximum adhesive pressure regardless of the motor speed past a certain point.

Then, increase motor speed in smaller increments (1 to 5%) until adhesive flow returns to the desired amount.

Note: This is the optimum point of operation for the motor, pump and pressure relief. It will also facilitate the best system performance and reduce wear on these components.

The application system is now adjusted for normal operation.

4.13 Level Control, Capacitive, Sensor with Amplifier

The level control device informs the Melter's operator, via a "Level Low" or "Level High" message on the controller's System Status display, that the Melter's hopper needs to be refilled or that it is overfull. It may also be wired to stop production.

The capacitive sensor is mounted in the hopper. The sensor cable is plugged into the amplifier.
DO NOT CUT the sensor cable.

Adjustment of the Single-Point Level Control, PN 810235

The single point level control monitors either a low or a high adhesive level.

To adjust the adhesive level control's sensitivity, access the control's amplifier, located inside the panel box assembly. On the amplifier (diagrammed below) is a calibration potentiometer (sensitivity adjustment).

Turn the potentiometer clockwise to increase sensitivity (or counterclockwise to decrease). Once calibrated, the yellow LED will light to indicate the presence of adhesive. When adhesive falls below the LED, the light will go out and the alarm will activate.

Use of Two-Level Controls in One Hopper:

Two single-point level controls can work together to maintain a range of adhesive in the Melter's hopper. In this application, one level control's sensor is mounted at the level of high adhesive and the other is mounted at the low level. Each amplifier requires its own calibration.

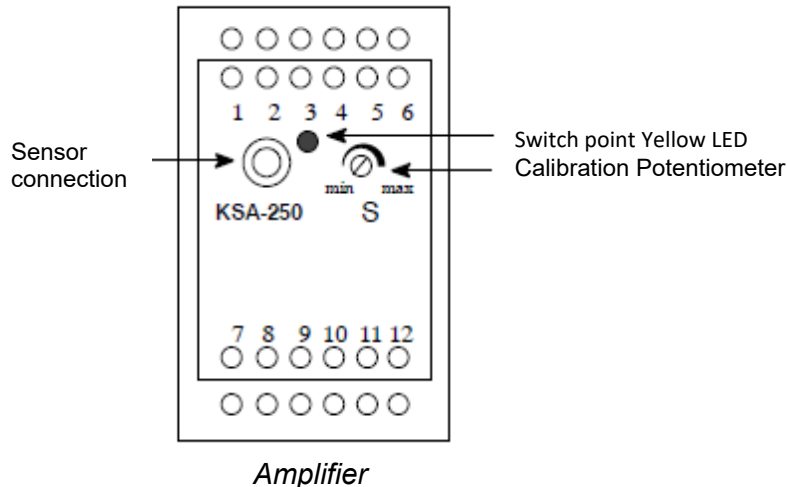

4.14 Typical Start-Up and Shut Down of the Application System Using the Touch Screen

The following simplified sequence assumes that the DynaControl Controller has been programmed.

Start Up Procedures

1. Fill the Melter's hopper with clean hot-melt adhesive to within a couple of centimeters (inches) of the top of the hopper. Close the hopper lid immediately to prevent contaminants from falling in. (Cover your bulk supply of adhesive to prevent contaminants also.)
2. Switch ON the Main Disconnect (the circuit breaker located on the panel box).
3. The Controller and the Touch Panel will start automatically. All system heaters go ON unless they have previously been de-activated (in which case they will be turned OFF) or if heating priorities have been set.
4. Allow adequate time (approximately 20- 30 min.) for the adhesive to melt and the temperatures of the temperature zones to stabilize. Observe the Status Line display at the Main Screen to see when "Not Ready" changes to "Ready".
5. When temperatures are ready, the pump and motor are enabled to pump adhesive.
6. At the Pump Overview Screen, select Auto or Manual Mode for each pump.

a. If Pump is in Auto Mode, select either Pump Control in Linear Line Speed or Pump Control, Pressure Control.

To select Pump Control in Linear Line Speed: Adhesive will begin to pump when the production line begins to operate.

- i. Select the pump for programming under the Settings column on the Pump Overview Screen.
- ii. Select Linear Line Speed in the Current Pump Mode menu. Press BACK.
- iii. Set the minimum and maximum setpoint value (RPM). The pump speed is controlled via a 0-10VDC signal provided by an external device (pattern control equipment or parent machine input). The minimum speed is necessary to keep the pump turning in order to maintain a minimum amount of adhesive pressure through the hose and applicator head.
- iv. Select the next pump (if applicable) under the Settings column on the Pump Overview Screen. Repeat steps i through iii until all pumps in the system are programmed.

To select Pump Control, Pressure Control: Adhesive will begin to pump when the pressure setpoint is reached.

- i. Select the pump for programming under the Settings column on the Pump Overview Screen.
- ii. Select Pressure Control on the Current Pump Mode menu. Press BACK.
- iii. Set the minimum and maximum setpoint value (RPM), the pressure setpoint value and the switch point value. The pump speed is controlled via the pressure signal provided by a pressure sensor.
- iv. Select the next pump (if applicable) under the Settings column on the Pump Overview Screen. Repeat steps i thru iii until all pumps in the system are programmed.

b. If Pump is in Manual Mode:

- i. Select the pump for programming under the Settings column on the Pump Overview Screen.
- ii. Set the manual setpoint value (RPM) under Manual Mode Settings.

- iii. Select the next pump (if applicable) under the Settings column on the Pump Overview Screen. Repeat steps i thru ii until all pumps in the system are programmed.

Shut Down Procedures

At the pump screen:

1. If Pump is in Auto Mode:

- a. Press STOP or ALL PUMPS STOP.
- b. Turn OFF the Main Disconnect Switch.

2. If Pump is in Manual Mode:

- a. Press STOP or ALL PUMPS STOP.
- b. Turn OFF the Main Disconnect Switch.

3. If the Scheduler is in use:

Turn OFF the unit with the Control Switch On/Off (i.e., on the Main Screen, press the Control button. Then, at the Control Switch/ Standby Screen, press On/Off).

Note: If the Scheduler is not in operation, use the Main Disconnect Switch to turn the unit OFF to avoid unexpected Melter activation in the event of a power outage.

4.15 Storage and Disposal of the DYNAMELT M Application System

Temporary Storage of the Unit

1. Flush the adhesive application system with flushing fluid (PN L15653), following the instructions detailed in chapter 6 of this manual.
2. Clean or replace both the outlet filter and the filter and shutoff assembly, following instructions detailed in chapter 6.
3. Shut OFF all pressure and power sources.
4. Release residual air pressure (if applicable).
5. Remove all residual adhesive and wipe components clean.
6. Remove all air lines (if applicable) and all power supply cables.
7. Pack the unit in a corrosion-proof manner.
8. Store the unit in such a way that it is protected from damage.

Disposal of the Unit

1. Shut OFF all pressure and power sources.
2. Release residual air pressure (if applicable).
3. Remove all residual adhesive.
4. Remove all air and adhesive hoses and all power supply cables.
5. Dismantle all components and sort into mechanical and electrical components.
6. Arrange for all components to be recycled.

Chapter 5

DynaControl V6 Controller

Rev.5.21



CAUTION: DO NOT damage the HMI's touch panel with sharp-edged tools.

CAUTION: DO NOT damage the touch panel by getting it wet.

CAUTION: Keep the touch panel clean.

5.1 Controller Set-Up

5.1.1 Software & Hardware Versions

The software & hardware versions of your controller and V6 modules are listed on the controller's System Info Screen. At the HMI's Main Screen, press the Settings button. On the Settings Screen, press the System Info button.

5.1.2 Temperature Control Functions in General

The DynaControl microprocessor-based proportional temperature control in the Melter performs a number of functions that help to maintain adhesive setpoints in all temperature zones of the DYNAMELT system. It maintains permanent system values such as the maximum temperature setpoint. It enables the user to program temperature settings and heater on/off sequencing that are appropriate to a specific application. It displays all programmed values, and it includes self-diagnostic malfunction alerts and failure alarms.

Note: Some DynaControl functions are direct temperature conversions between degrees Celsius and Fahrenheit. Other parameters are independently selected values.

5.1.3 Defining DynaControl Temperature Control Terms

Adhesive Temperature Control Range

The temperature limits within which the Melter, hoses and applicators may be programmed and maintained.

Default Settings

The factory-set programmable system values that will be in effect if the user does not enter new values. The controller will revert to its defaults whenever it is reset.

EtherNet Serial Communication

A bi-directional data transfer connection to a remote PLC which enables system parameters to be monitored and/ or controlled from the remote station.

Faults/ Alarms

Controller alarms which indicate that the programmed over-temperature values have been exceeded for one or more hopper, hose or head zones or that a zone temperature has fallen beneath its hi-lo tolerance. Alarms may also indicate an open or short-circuited sensor.

Heating Priority

The heating sequence which allows the slower-heating hopper to reach operating temperature without unnecessary use of electricity for faster-heating hoses and applicators. Heating priority is the time period during which the hoses and applicators remain OFF while the hopper (and optional drop-in grids) heat up. Hoses and applicators may be independently programmed. If hopper temperature is above ready temperature when the Melter is turned ON, the hose and applicator priority sequence is bypassed and they will be turned ON. The heating priority is restored after Standby is turned from ON to OFF. Priority heating is not needed for most applications.

Power Modules & Power PCBs

Each power module consists of two printed circuit boards (PCBs). They provide power to all the temperature zones in the Melter's system. The standard unit's hopper, hoses and applicators are controlled by the Power PCBs. Additional hoses and applicators are controlled by the PCB(s) on additional power modules, if required.

Microprocessor-based Proportional Temperature Control

The built-in control system that controls, monitors and displays all system temperatures.

Over-Temperature Setpoint

The programmable temperatures that will cause alarms to occur when those temperatures are exceeded. Power is not disconnected; the READY contact opens and the alarm contact opens. If an external alarm has been connected, it will activate. The over-temp setpoint is the upper limit of the ready temperature range of each zone.

Pump Enable Temperature

The pump enable temperature protects the pump, pump shaft, motor and motor control board from damage by not allowing the pump to activate until a low limit (the programmed pump enable temperature) is achieved. The pump enable temperature is independent from the zone temperature setpoints. This feature serves as a redundant safety measure.

RTD Sensors

The standard Dynamelt system uses 100-ohm platinum resistance temperature detector sensors for all temperature controls. As an option, the unit can be configured for 120-ohm nickel sensors.

Ramp Compensation

A feature of the touch panel HMI. Programmed parameters automatically regulate the amount of adhesive applied as production speeds accelerate and decelerate.

Recipe

A program recipe is a set of temperature setpoints and parameters which the user has programmed and wishes to store in the controller for future use.

Scheduler

The Scheduler enables the controller to provide scheduling of ON and OFF times of the Dynamelt Melter system by the use of timers. Up to three Scheduler timers may be programmed. The operator may program ON and OFF heating cycles which coincide with his production schedule through the work week. The Scheduler helps conserve electricity usage and also serves as an additional safety feature.

Setpoint

A programmed temperature that has been selected for each of the temperature zones.

Setpoint Limitation

This is a universal maximum temperature for all zones. The programmer cannot program a temperature setpoint higher than the setpoint limitation. If the actual temperature of any zone climbs higher than the setpoint limitation, all heaters will shut down.

Standby Condition

The system condition where the Melter, hose and head temperatures are maintained at predetermined reduced temperature values. Standby temperatures are set lower than setpoint temperatures in order to reduce adhesive degradation and energy consumption when the system is temporarily inactive, and to permit rapid system warm-up when run condition is selected. When standby mode is activated, the controller will display STANDBY.

Temperature Alarm Hysteresis

This is a second, smaller, temperature range and alarm limit programmed in addition to the Temperature Alarm Window which allows the unit to remain in Ready condition as temperatures stabilize after start-up. The Temperature Alarm Hysteresis is a deviation (+/-) from the Temperature Alarm Window.

Temperature Alarm Window

This is the programmable temperature range which allows the unit to go into Ready condition. The Temperature Alarm Window is a deviation (+/-) from the setpoint. The setpoint minus the deviation is the low limit of the window, and the setpoint plus the deviation is the high limit of the window. The Temperature Alarm Window (+/- the Temperature Alarm Hysteresis, if programmed) will trigger high and low temperature alarms when zone temperatures rise or fall outside of the window.

Temperature Zone Enable

The temperature zone enable allows the operator to disable unused temperature zones in such a way that they do not appear on the controller's display and heating is switched OFF.

Temperature Zone Offset

Temperature zone offsets are mathematical factors which compensate for differences in temperature within components. Each temperature zone may be programmed with an offset, if desired. Standard equipment does not usually require temperature offsets.

V6 Base Module

The main control module of the system. It controls and communicates with the temperature control module, the operator interface and all auxiliary modules and I/O devices.

V6 BUS Communication Module

The module which allows remote communication. Several communication protocols (EtherNet, EtherCat, Profibus, etc.) can be adapted by the BUS Module.

V6 Temperature Module

Monitors temperature signals from all heated zones and provides control signals to the Power and Auxiliary PCBs (modules).

5.1.4 Error Indication Faults & Alarms

If a fault/ alarm occurs, the Acknowledge button (on the Main Screen) and the temperature zone will be highlighted in red. The controller will turn off the internal power to the heaters and an appropriate alarm indication will appear in the status line of the controller's display.

The operator must either turn Off the indicated temperature zone(s) or troubleshoot to correct the problem. Then press the Acknowledge button in order to turn on the main contactor and reset the error. If more than one alarm condition occurs simultaneously, the alarms will be displayed sequentially, and each alarm must be acknowledged.

When an alarm occurs, the current display will be interrupted only if a sensor (or a motor drive) failure has occurred. When the actual temperature exceeds the setpoint limitation (plus a tolerance) the over-temperature alarm is displayed, and main power is switched Off.

5.1.5 Error Alarms in Status Line

Among the Faults and Alarms that may be displayed on the controller's status line are:
RTD Fault: a hopper, hose or applicator head RTD sensor has an open circuit.

Temperature Alarm:

1. a temperature zone has exceeded its selected over-temperature setpoint, (which is the setpoint plus the Temperature Alarm Window and Temperature Alarm Hysteresis), or
 2. a temperature zone is below its selected under-temperature setpoint (which is the setpoint minus the Temperature Alarm Window and the Temperature Alarm Hysteresis).
- Drive Failure: a motor drive (frequency converter) has a fault.
 - Minimum Level: the adhesive level has dropped below the level sensor and the hopper is empty.
 - Feedback Failure Motor #: (optional) speed monitor pump addressed.
 - Overtemperature: hardware over-temperature indication.
 - Communication Error: there is a communication error between the touch panel and controller.
 - Parameter CRC Error: parameter memory has been lost. Call ITW Dynatec Technical Service.
 - Other Faults or Alarms: call ITW Dynatec Technical Service.

5.1.6 Controller's Log Book

The controller's Log Book Screen provides a list of the last 100 controller alarms, faults and events.

To go to the Log Book, press the Settings button on the Main Screen. Then press the Log Book button on the Settings Screen.



WARNING USE OF SCHEDULER FEATURE

The controller's Scheduler feature allows automatic start-up and shut-down of the unit's heating and rotating components, which may present an unexpected hazard to those unfamiliar with it. Users, service technicians and others in the vicinity of the machine should be made aware of this possibility in order to mitigate the risk of injury.

5.1.7 Optional System Status Lights

This tri-color stack light eases remote monitoring of the system's status. The lower, white light illuminates when the system is turned ON. The middle, green light indicates that the system has warmed up to temperature setpoints ("ready"). The upper, red light illuminates only in an alarm condition and is accompanied by an audible alarm. The audible alarm is housed within the upper (black) section of the stack.

The status lights may be wired to indicate either high/low temperature, low adhesive level or open/short sensor. See Chapter 11 for wiring diagram.

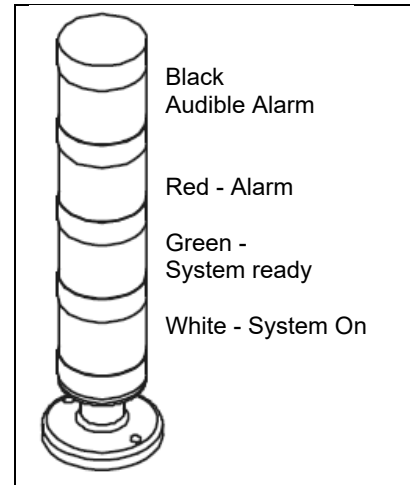

5.1.8 Settings for a Typical Operation

Note: The values given here are approximate settings for a typical packaging operation. The values you choose will be based on the type of equipment and adhesive you are using and the nature of your particular operation.

If Application Temperature is 177°C (350°F):

Hose and head temperature: 177°C (350°F).

Hopper setpoint temperature: 163°C (325°F).

Hi/ Lo limit deviation: 12°C (20°F).

Melter operating range: 149°C to 177°C (300°F to 350°F).

Standby condition temperature (deviation): 30°C (50°F).

Hopper over-temperature setpoint: 177°C (350°F)

Mechanical thermostat (for the hopper) over-temperature: 233°C (450°F)

For most operations, temperature fluctuations will be very small and of short duration. For these reasons, the settings above are recommended.

5.1.9 Helpful Tips for the User

When the Melter is turned ON, all temperature setpoints and other operating parameters will be exactly where they were when the Melter was turned off.

When the Melter is turned ON, all system heaters go ON if the automatic heater startup is enabled and if setpoints are programmed unless sequential heat-ups have been set.

However, if hopper temperature is above ready temperature when the Melter is turned ON, all hose and head sequential heat-ups will be bypassed and hoses and heads will be turned ON.

If the system is turned OFF and then ON again, the standby condition will be disabled.

5.2 Security advice



CAUTION

- Do not damage Touch Panel with sharp edged tools or similar!
- Do not besprinkle Touch Panel!
- Keep the Touch Panel always clean!

The Controller and the Touch Panel start automatically when switching on the main switch and pressing the button „Controller ON“.

The Touch Panel is self-explanatory.

- Press the particular function field and the appropriate function will be activated.
- Press the desired function and the value can be entered or changed.

All settings and controller can be done using the Touch Panel; e.g. for

- temperatures,
- times,
- speed, etc.

5.3 Program Your System's Parameters

- Program the controller parameters to meet the specific temperature requirements of your production. Setpoints for each temperature zone must be programmed as well as a standby temperature, pump enable temperature, temperature alarm window and temperature alarm hysteresis.
- Choices must be made for recipe (program) selection, pump (or motor) conditions and heating priority. If desired, temperature zone offsets and/ or a temperature zone enable may be selected.

5.4 Numeric Entry Keypad

- Use the numeric entry keypad to enter or change numeric parameters (values).
- In the top window, the temperature zone name and its setpoint value will be displayed.

This is a typical example of the numeric entry keypad:

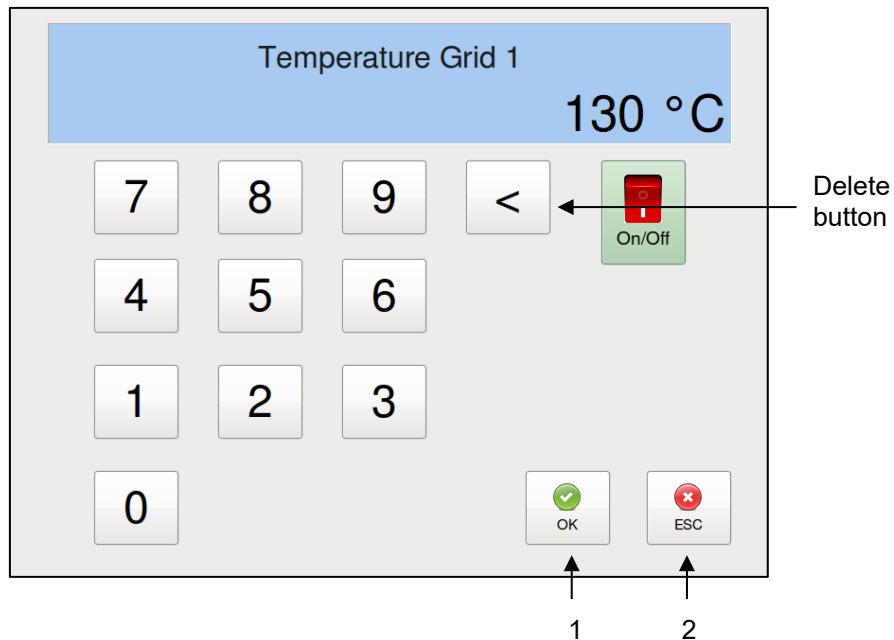

Item	Description
1	By pressing the OK button, the entered values will be confirmed and stored in the controller. The numeric entry keypad closes, and you will return to the previous screen.
2	By pressing the ESC button any entered but not yet confirmed values will be discarded and you will return to the previous screen.

5.5 Alphabetic Entry Keypad

- Use the alphabetic keypad to enter or change text, e.g. temperature zone names.
- In the top window, the temperature zone name will be displayed.

This is a typical example of an alphabetic keypad:

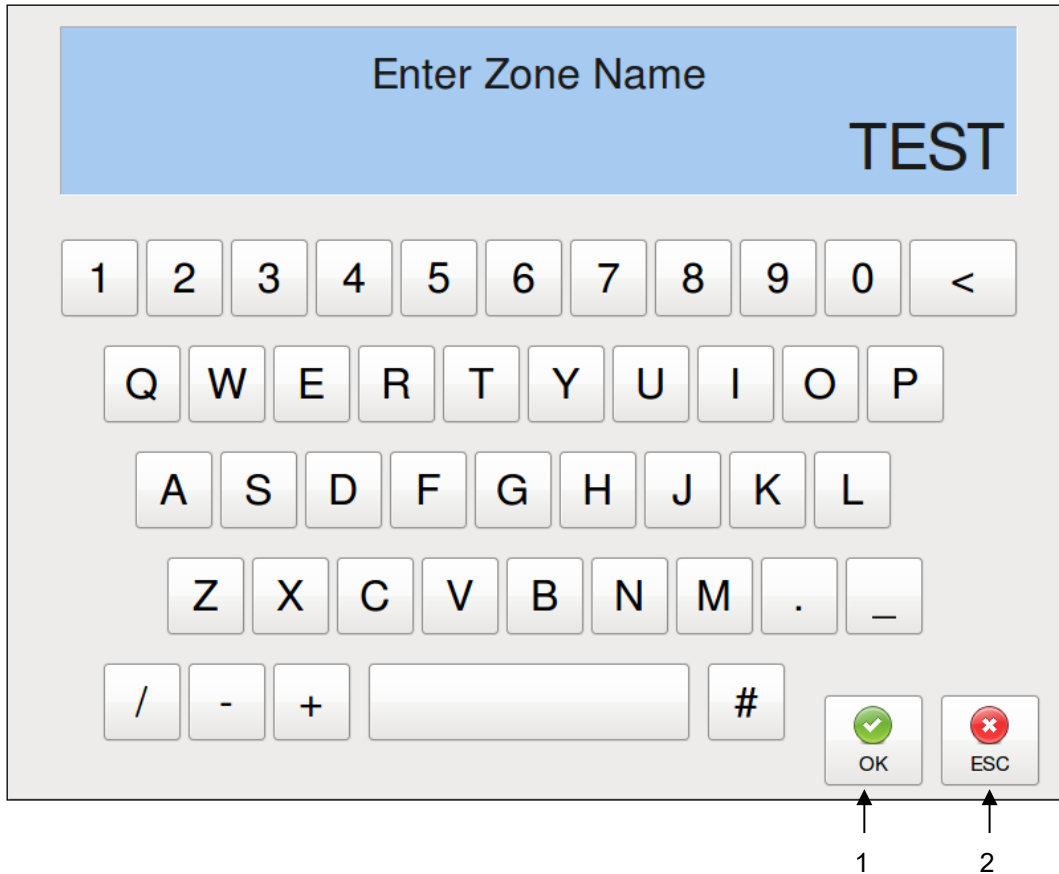

Item	Description
1	By pressing the OK button, the entered text will be confirmed and stored in the controller. The alphabetic entry keypad closes, and you will return to the previous screen.
2	By pressing the ESC button any entered but not yet confirmed text will be discarded and you will return to the previous screen.

5.6 Main Screen

- The Main Screen is displayed automatically when the unit is switched ON.
- The Main Screen provides a comprehensive overview of the status of each of the temperature zones and the system as a whole. It gives the status and speed of the pump, along with any adhesive pressures and level status.





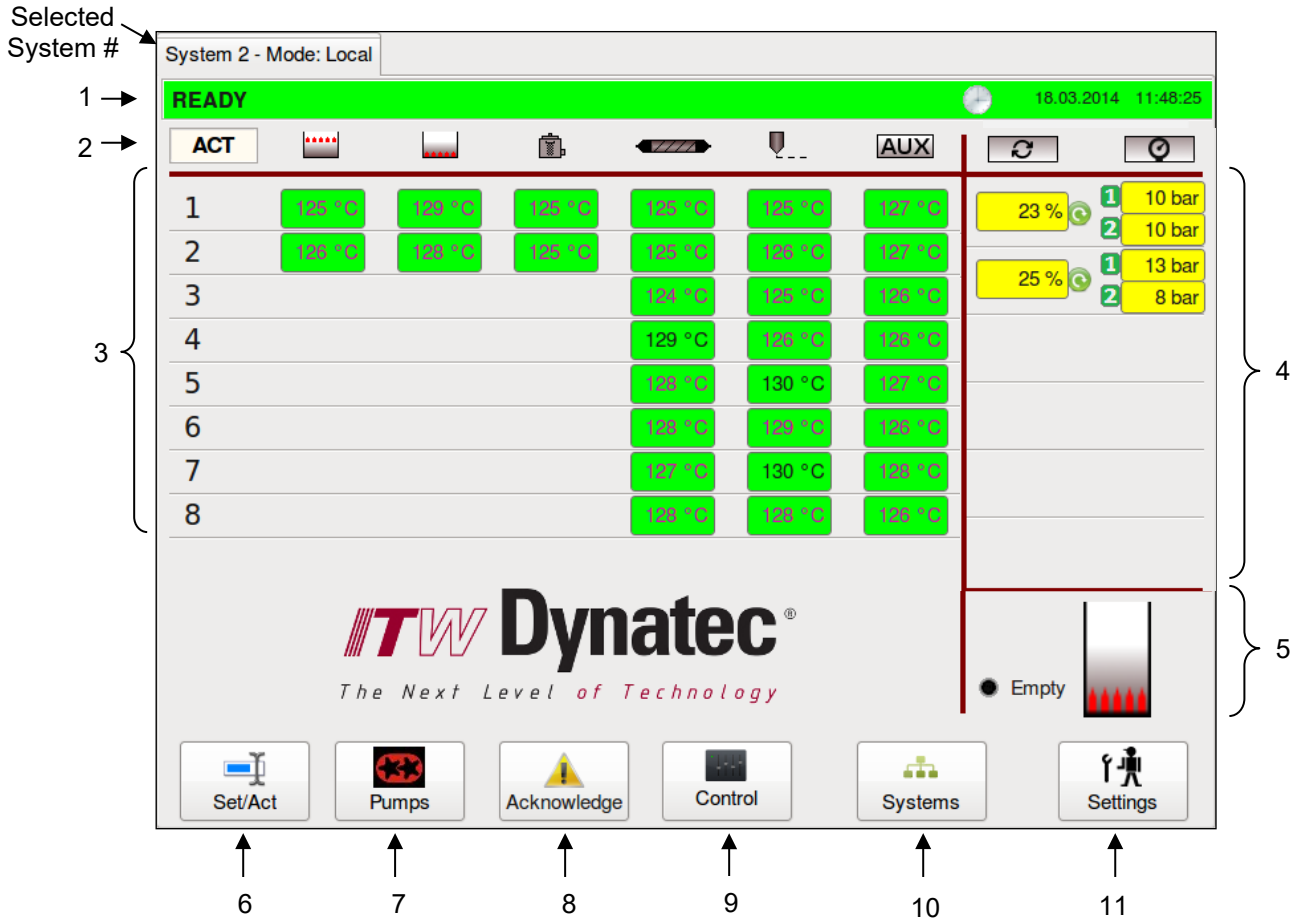



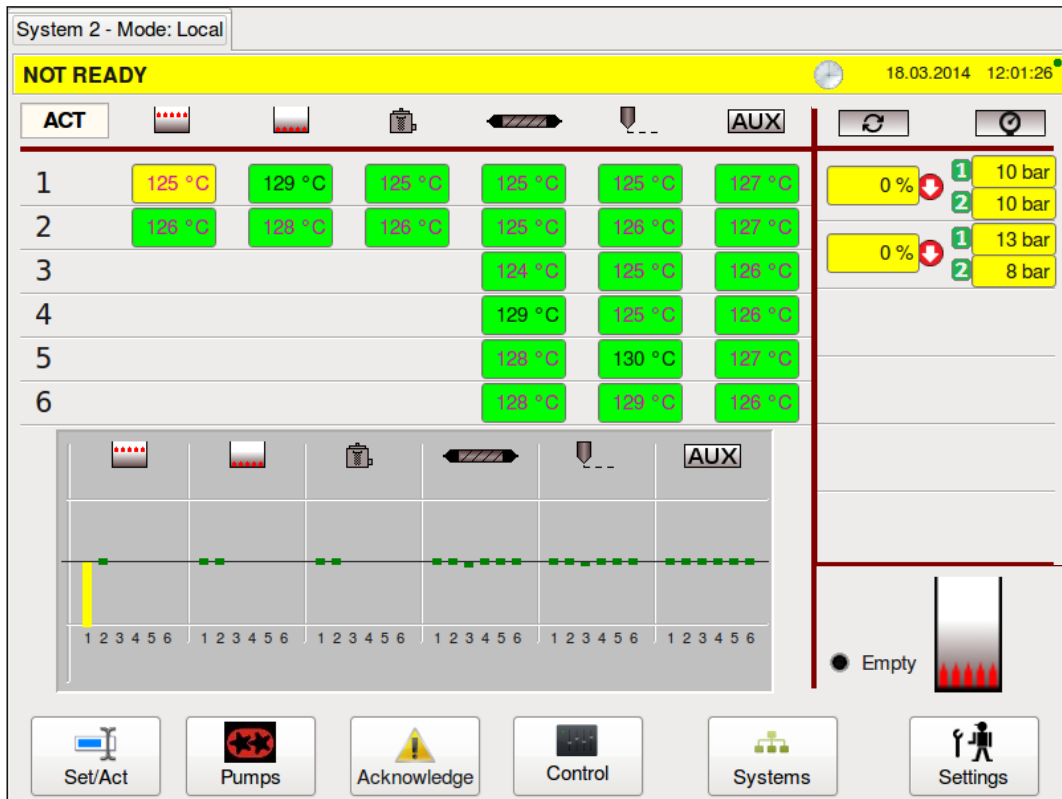
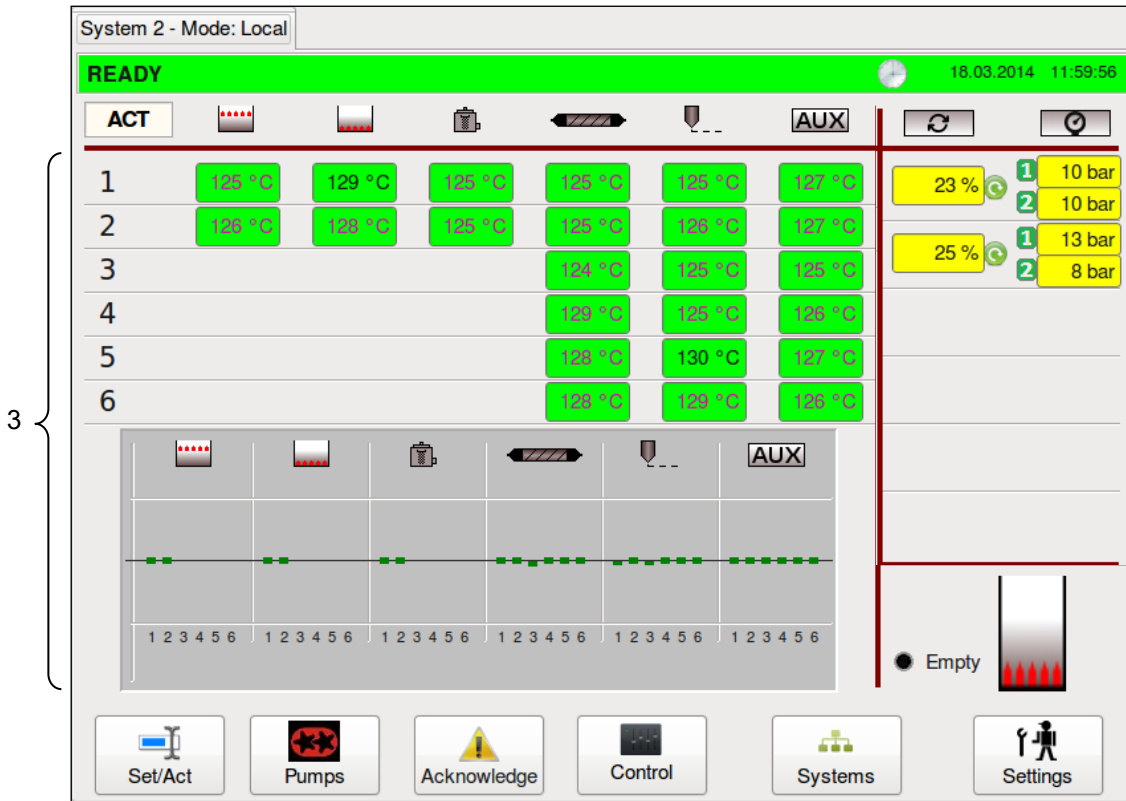

NOTE: The screens in this manual are partially sample screens!





Main Screen, if seven or more zones in any column are activated:



Main Screen, if six or fewer zones in any column are activated:

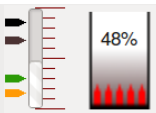

Item	Description
1	<p>Status Line Display of the actual status of the unit:</p> <ul style="list-style-type: none"> • READY = All zones are within their setpoint temperatures and the unit is ready for operation. • RUNNING = All zones are within their setpoint temperatures and the unit/pump is running. • NOT READY = At least one zone has not yet reached its setpoint temperature or has fallen below its set point or it is lower than the set global release temperature. • STANDBY = Standby temperature is activated. • ALARM = Alarms or faults are active. <p>The status line is highlighted <u>green</u> when the system is READY or RUNNING, <u>yellow</u> when NOT READY, <u>grey</u> when in STANDBY and <u>red</u> when in ALARM condition.</p> <p>The status line along with “Systems” button is in orange color if a non-visible system goes into Alarm condition (if several systems are controlled by the HMI).</p> <p>The „clock“  icon appears if a timer is activated under “Time & Scheduler” screen and disappears if the timer is deactivated.</p> <p>Display of the actual date and time are on the right side of the screen. Depending on the selection of the unit of temperature and pressure (°C and bar or °F and psi) made under Unit & Date Selection, the appearance of the date display is affected also. With the C/bar selection, the date is displayed as ‘day.month.year’ while in F/psi mode, the date is displayed as ‘month/day/year’. The time is displayed as hour.minutes.seconds (i.e., 11:48:25 pm).</p> <p>By pressing the status line you go to the Log Book screen.</p>
2	<p>Icon Line ACT / SET: Indicates if the temperature values shown on the display are Actual or Setpoint values. The Actual values will be displayed during production. By pressing the Set/Act button, the Set values can be displayed and edited. The display returns automatically to the Actual values after about 15 seconds if there is no activity.</p> <p>The icons:</p> <ul style="list-style-type: none">  Pre-Melt Grid  Hopper  Filter manifold  Hose  Applicator  Auxiliary components  Pump RPM  Pressures  Decentralized pumps (e.g. Applicator, Metering Station:  A plausible limit value of Input Pressure (a minimum pressure of not less than 2 bar is recommended) has to be entered to avoid a dry run of the pumps; otherwise the pump can be damaged. See point “Extended Pump Mode Settings Screen, Linear Line Speed, Pressure Control”. <p>The appropriate actual values (temperature, pump rpm, pressures) are displayed under the icons.</p>

Item	Description
3	<ul style="list-style-type: none"> The actual values of the temperature zones are displayed in columns under the icons. Zone status is indicated by color: the zone field is colored green when the zone reaches setpoint, yellow while the zone is heating up, grey if it has been temporarily switched off and red if in alarm. When all zones have reached their setpoint values, READY will be displayed in the status line. If zones are still heating up and have not yet reached their setpoint values, NOT READY will be displayed in the status line. If six or fewer zones in any column are activated, the temperature status of each zone is shown by a bar-graph indicating if the temperature zone is inside its setpoint window (green) or outside (yellow). The bar-graph indication disappears if more than six zones are activated.
4	<p>The appropriate actual values (pump rpm, pressures) are displayed under the icons.</p> <p> Primary pressure: If the system is equipped with a (primary) pressure sensor, the appropriate primary pressure transducer input will be displayed with number 1. The primary pressure input can be controlled via the Pressure Set Point in Pump Control/ Pressure Control Screen.</p> <p> Secondary pressure: If a second pressure sensor is equipped (usually in combination with dual pump outlets), the appropriate pressure transducer input will be displayed with number 2. The secondary pressure input is just a readout function.</p> <p>  Pressure Discrepancy Alarm: If the display fields are highlighted red, it indicates that the (optional) pressure discrepancy has detected an excessive difference between the primary and secondary pressure. See point "Extended Pump Mode Settings Screen, Linear Line Speed, Pressure Control" for further information.</p>
5	<p> If an optional digital level sensor is built-in, Hopper Empty status will be indicated when adhesive drops below the level sensor.</p> <p> If an optional analog probe used the status bar will display the adhesive level along with a percentage of hopper volume.</p>
6	<p>Set/Act Button By pressing Set, values may be displayed and edited. The display will automatically return to actual values after about 15 seconds, if there is no display activity.</p>
7	<p>Pumps Button Press to go to the Pump Overview screen.</p>
8	<p>Acknowledge Button Press to acknowledge an error or alarm.</p>
9	<p>Control Button Press to go to the Control screen.</p>
10	<p>Systems Button Press to go to the Systems screen, if several systems are controlled by the HMI.</p>
11	<p>Settings Button Press to go to the Settings screen.</p>

5.7 Temperature Zones Set Screen

- To go to this screen, press the Set/Act button on the Main Screen.
- The Set screen allows you to program the setpoint temperature for each activated zone. Each zone requires a temperature setpoint.
- When a temperature zone is not used, it can be de-activated (turned OFF) on the Heating Priority screen. A zone that is turned Off no longer heats and is not monitored by the controller for over or under temperatures.

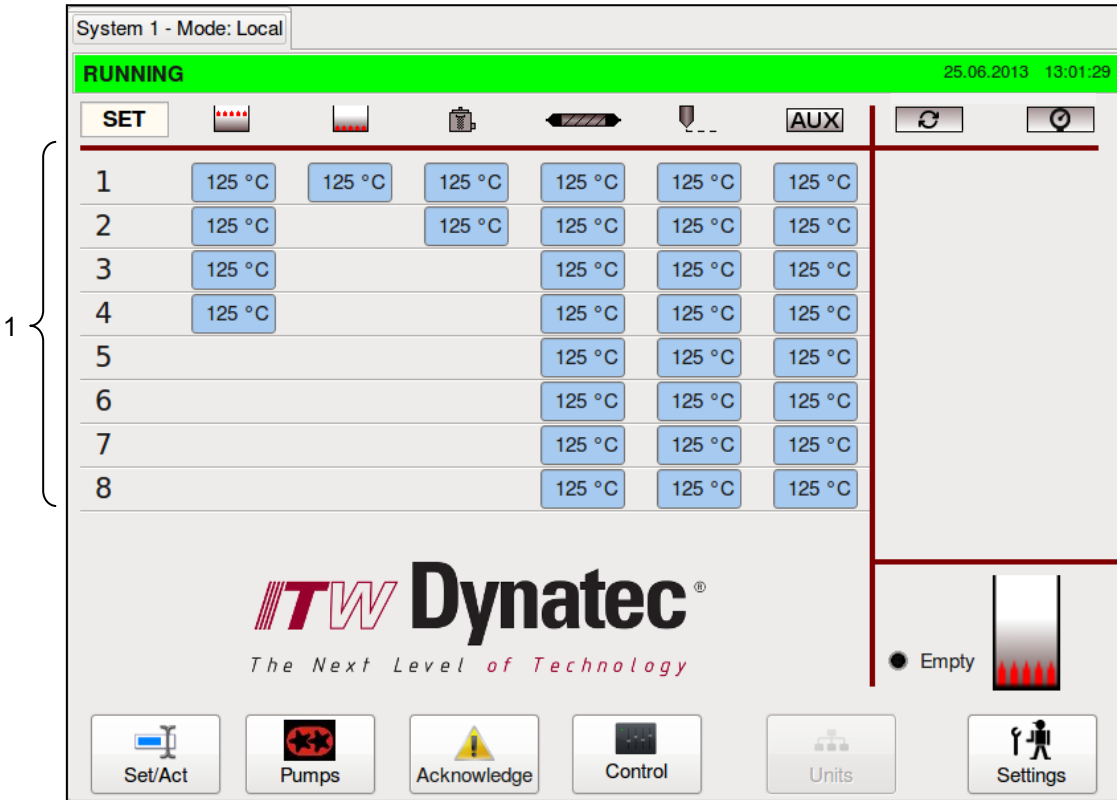

Item	Description
1	<p>Set values</p> <ul style="list-style-type: none"> • Display of the temperature setpoint values. • To edit values: Touch a zone input box and a numeric entry keypad will appear. Enter your new setpoint value and confirm by pressing OK. NOTE: Must be below the maximum setpoint value listed below. • The Set values are displayed for about 15 seconds and, if there is no display activity, the display returns automatically to the Actual values. • The maximum setpoint value is 218°C (424°F).

- See next page for Zone On/Off Switch on the Numeric Entry Keypad.

5.7.1 Zone On/Off Switch on the Numeric Entry Keypad

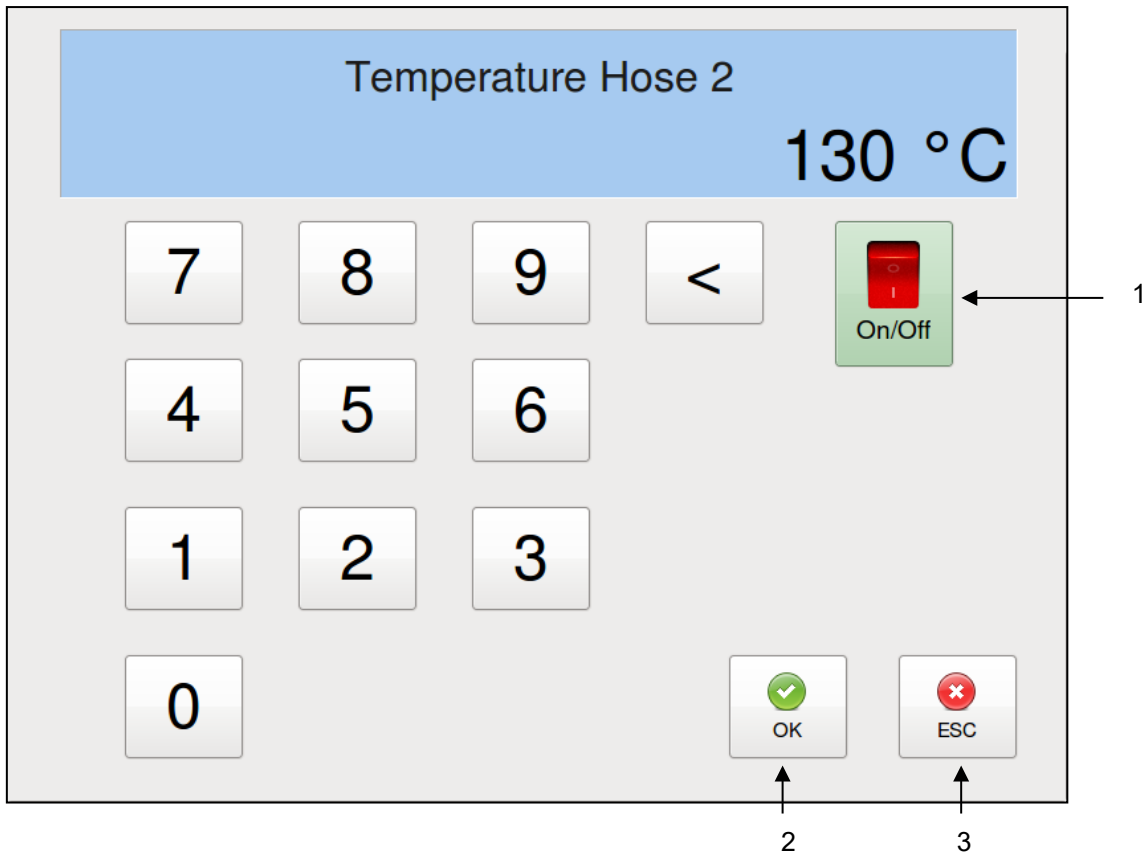

Item	Description
1	<p>Zone On/Off Switch</p> <ul style="list-style-type: none"> Zones can be activated/ deactivated temporarily. A system with a hopper zone off or pump/motor zone off will put the system in NOT READY state which does not let the motors run. The switch is colored light green if ON and light red if OFF.
2	By pressing the OK button, the entered values will be confirmed and stored in the controller. The numeric entry keypad closes, and you will return to the previous screen.
3	By pressing the ESC button any entered but not yet confirmed values will be discarded and you will return to the previous screen.

5.8 Pump Overview Screen

- To go to this screen, press the Pumps button on the Main Screen.
- While on the Pump Overview Screen, all changes are immediate (you do not need to confirm).
- The Pump Overview Screen allows you to program the pump mode (Manual, Stop or Automatic). Each pump in the system must be programmed with a Pump Mode.
- Decentralized pumps (e.g. Applicator, Metering Station:  A plausible limit value of Input Pressure (a minimum pressure of not less than 2 bar is recommended) has to be entered to avoid a dry run of the pumps; otherwise the pump can be damaged. See point “Extended Pump Mode Settings Screen, Linear Line Speed, Pressure Control” on next pages.

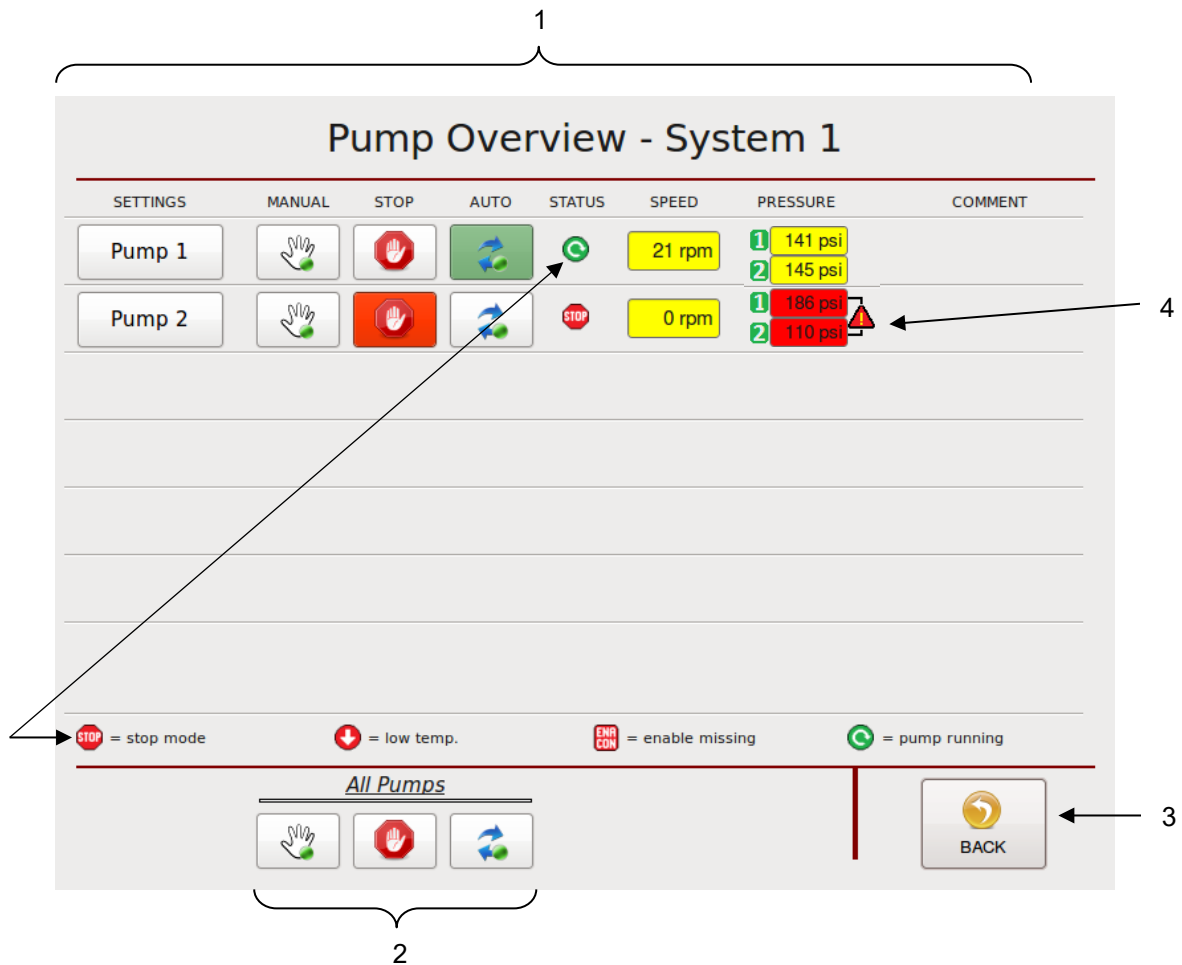

Item	Description
1	<p>Pump Overview</p> <ul style="list-style-type: none"> • SETTINGS: Press Pump 1, Pump 2, etc. to go to the appropriate Pump Control screen. • MANUAL: The pump speed is adjusted manually by the operator. When selected the MANUAL icon is highlighted green. • STOP: The pump is stopped, until AUTO or MANUAL is selected. When selected, the STOP icon is highlighted red. • AUTO: The pump speed is controlled via a 0–10VDC signal that is provided by an external device (pattern control equipment or parent machine input). When selected, the AUTO icon is highlighted green. Auto operating parameters for each Pump must be set on the Pump Control Screen. • STATUS: Indicates the pump status. <i>See icons line/description at the bottom of the screen.</i> <ul style="list-style-type: none"> - Stop Mode = Pump is stopped. - Low Temp. = Melter has not reached setpoint temperature. - Enable Missing = Pump enable signal is missing from customer contact. - Pump Running = Pump is running. • RPM: The actual (calculated) RPM of each pump will be displayed. • PRESSURE: The pressure for each pump (if available) will be displayed. See explanation under Main Screen point 4. • COMMENT = The entered pump name will be displayed.
2	<p>All Pumps Buttons</p> <p>Press one of the All Pumps buttons (either MANUAL, STOP or AUTO) to set all pumps to the desired function at one time.</p>
3	<p>BACK Button</p> <p>Press to return to the previous screen.</p>
4	<p>Pressure Discrepancy Alarm:</p> <p>If the display fields are highlighted red, it indicates that the (optional) pressure discrepancy has detected an excessive difference between the primary and secondary pressure. See point “Extended Pump Mode Settings Screen, Linear Line Speed, Pressure Control” for further information.</p>

5.8.1 Pump Control Screen/ Linear Line Speed

- To go to this screen, press the Pump 2 field on the Pump Overview screen (to go to the Pump 1, etc. Control screen, press the corresponding field). Then press the Settings button, select Linear Line Speed in the Current Pump Mode menu on the Extended Pump Mode Settings screen and then press the BACK button.
- The Pump Control Linear Line Speed screen allows you to program the Auto Mode Settings (Setpoint minimum/maximum RPM at 0–10VDC external signal control) and Manual Mode Settings (Manual Setpoint RPM).

Pump 2 Example:

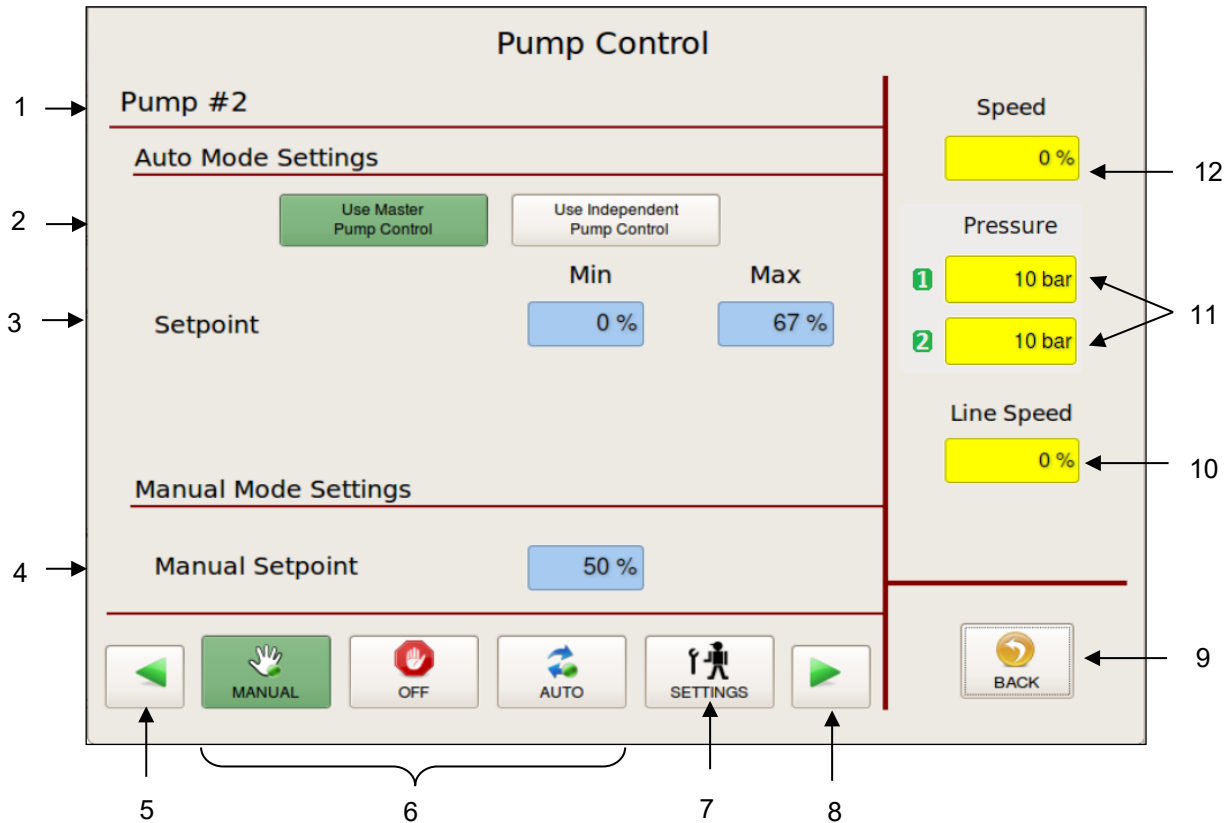

Item	Description
1	Pump #2 is the selected pump. All the settings and speeds displayed on this screen correspond to Pump #2.
2	Auto Mode Settings Press the according switch for pump control. The activated switch is highlighted green. <ul style="list-style-type: none"> • Use Master Pump Control: The selected pump will use the START/STOP signal and the 0-10V speed signal that pump #1 uses. • Use Independent Pump Control: The selected pump will use its own START/STOP signal and 0-10V speed signal.
3	Auto Mode Settings Setpoint The minimum and maximum setpoint values of the pump are displayed. The programmable range is 0 to 90 rpm or 0 to 100%. By pressing the input field, you can edit the RPM or % values.
4	Manual Mode Settings Manual Setpoint The manual setpoint value of the pump is displayed. By pressing the input field, you can edit the value.

Item	Description
5	Press the arrow icon to go to the previous pump screen (i.e., Pump 1, etc.).
6	<p>Set the pump to the desired mode by pressing MANUAL, OFF (STOP) or AUTO.</p> <ul style="list-style-type: none"> MANUAL: The pump speed is adjusted manually by the operator. If MANUAL is selected the icon is highlighted green. OFF (STOP): The pump is stopped, until AUTO or MANUAL is selected. If OFF is selected the icon is highlighted red. AUTO: The pump speed is controlled via a 0–10VDC signal that is provided by an external device (pattern control equipment or parent machine input). If AUTO is selected the icon is highlighted green. <p>A minimum speed is necessary to keep the pump turning in order to maintain a minimum amount of adhesive pressure through the hose and applicator head. For instance, if the input signal is 10VDC at 100 meters per minute and the pump percentage of full speed is 100% (maximum speed), but the system is putting out too much adhesive, adjusting the MAX pump percentage to 50 will cause the pump to slow down over the parent machine's entire speed range and adhesive output will be decreased.</p>
7	<p>Settings Button Press this button to go to the Extended Pump Mode Settings screen where you can select the Current Pump Mode "Linear Line Speed" or "Pressure Control" and you can go to the "Automatic Ramp Compensation" screen.</p>
8	Press the arrow icon to go to the next pump screen (i.e., Pump 3, etc.).
9	<p>BACK Button Press to return to the previous screen.</p>
10	LINE SPEED: The actual (or calculated) line speed is displayed.
11	PRESSURE: The actual pressures are displayed. See explanation under Main Screen point 4.
12	SPEED: The actual (or calculated) pump speed is displayed.

5.8.2 Extended Pump Mode Settings Screen, Linear Line Speed, Pressure Control

- To go to this screen, press the Settings button on the Pump Control screen.
- The Extended Pump Mode Settings screen allows you to select the Current Pump Mode and to go to the Automatic Ramp Compensation (ARC) screen.

System 1 Pump 2 Example:

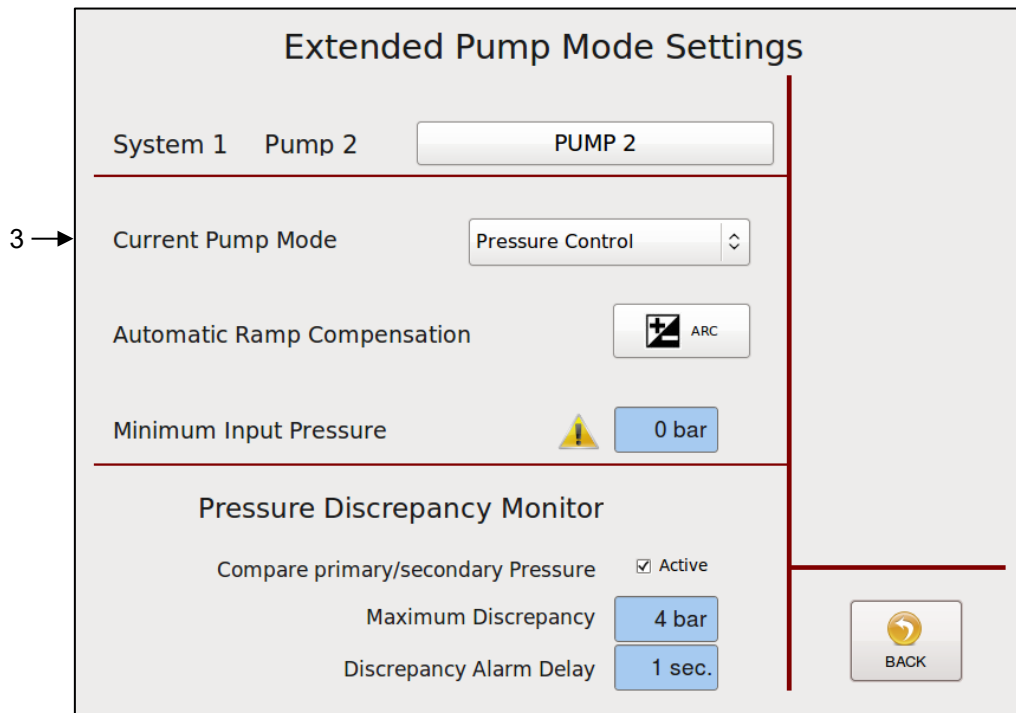
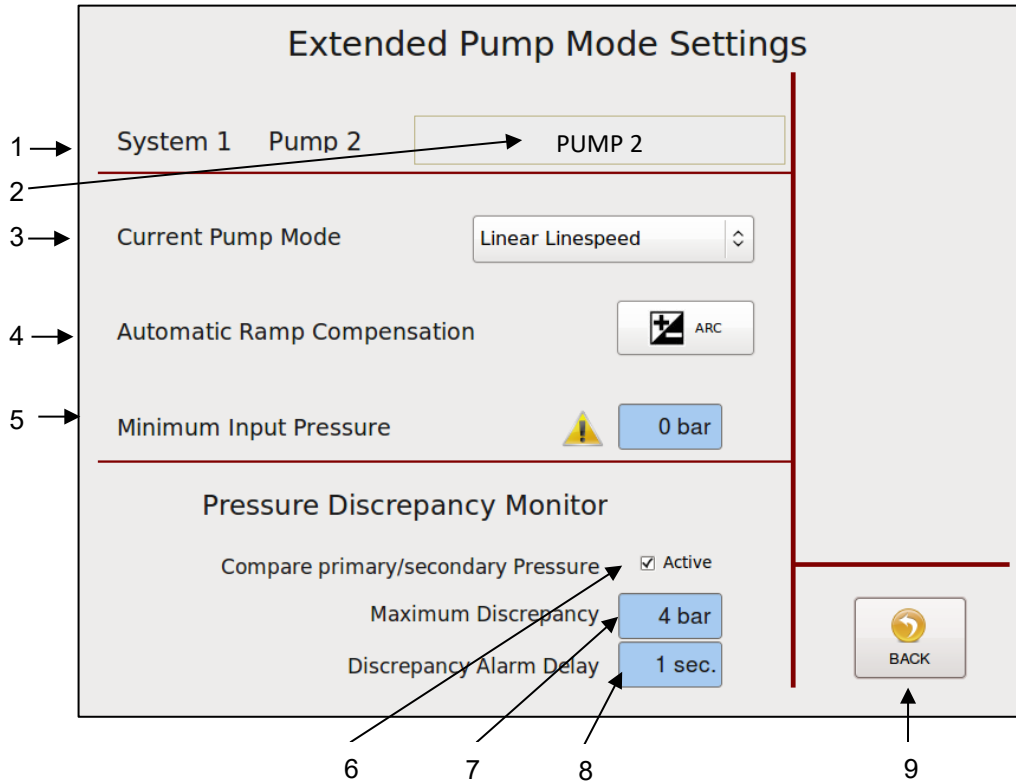

Item	Description
1	System 1 Pump 1 is selected.
2	Pump Name Touch the input box and an Alphabetic Entry Keypad will appear. Enter your desired pump name and confirm by pressing OK. The entered pump name will be displayed on the Pump Overview Screen.
3	Current Pump Mode Press Current Pump Mode to select "Linear Line Speed" or "Pressure Control". Then press the BACK button to go to the appropriate screen.
4	Automatic Ramp Compensation (ARC) Button Press to go to the Automatic Ramp Compensation screen.
5	Optional: Minimum Input Pressure <ul style="list-style-type: none"> This field appears only if the pump is configured for a minimum input pressure lock. The Minimum Input Pressure is a customer parametrizable value which has to be reached for the according pumps on decentralized pump (Applicator or Metering Station) to be released.  A plausible limit value of Input Pressure (a minimum pressure of not less than 2 bar is recommended) has to be entered to avoid a dry run of the pumps; otherwise the pump can be damaged.
6	Pressure Discrepancy Monitor Check this button if the pressure discrepancy has to be monitored.
7	Maximum Discrepancy This is the maximum allowed difference and adjustable between 1-17 bar (15-250 psi). If actual difference is larger, a discrepancy warning will be generated for reference only.
8	Discrepancy Alarm Delay A pressure discrepancy warning can be delayed. This way an excessive difference has to be present for a minimum time to cause a warning.
9	BACK Button Press to return to the previous screen.

5.8.3 Pump Control/ Pressure Control Screen

- To go to this screen, press the Pump 2 field on the Pump Overview screen (to get to the Pump 1, etc. Control screen, press the corresponding field). Then press the Settings button, select Pressure Control in the Current Pump Mode menu on the Extended Pump Mode Settings screen and then press the BACK button.
- If (optional) pressure sensors (transducers) are installed on the unit, the pumps can be pressure controlled. Pressure values (Bar/PSI) will be displayed on the Main Screen.
- A plausible limit value of Input Pressure (a minimum pressure of not less than 2 bar is recommended) has to be entered to avoid a dry run of the pumps; otherwise the pump can be damaged. See point “Extended Pump Mode Settings Screen, Linear Line Speed, Pressure Control” on previous pages.

Pump 2 Example:

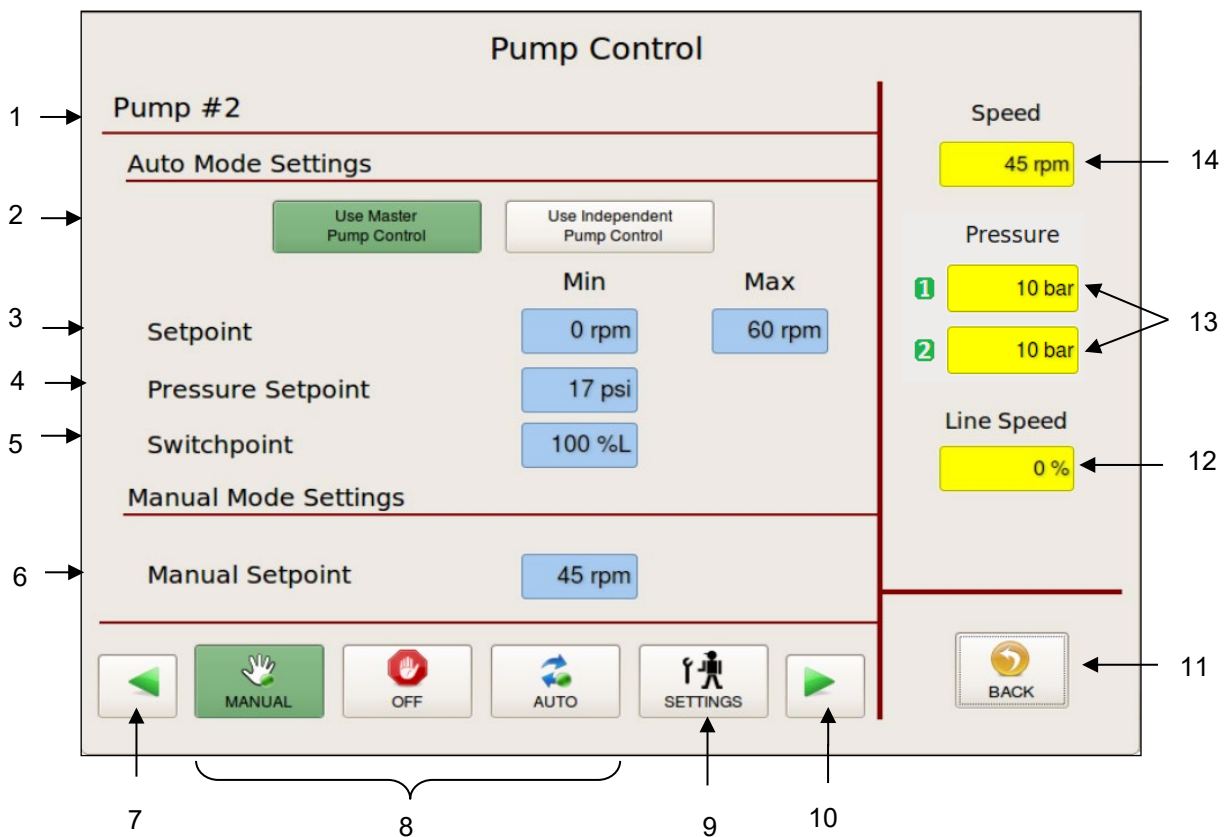

Item	Description
1	Pump #2 is the selected pump. All the settings and speeds displayed on this screen correspond to Pump #2.
2	Auto Mode Settings: Press the according switch for pump control. The activated switch is highlighted green. <ul style="list-style-type: none"> • Use Master Pump Control: The selected pump will use the START/STOP signal that pump #1 uses. • Use Independent Pump Control: The selected pump will use its own START/STOP signal.
3	Setpoint (if in Auto Mode only) The minimum and maximum setpoint RPM of the pump are displayed as programmed. Press the input field to edit the values.

Item	Description
4	<p>Pressure Setpoint (if in Auto Mode only) The pressure setpoint value (BAR/PSI) is displayed as programmed and it controls the primary pressure input (point 11). Press the input field to edit the value.</p>
5	<p>Switch Point (if in Auto Mode only) Switch Point is set at a percentage of line speed. In the example shown above, 10%L equals 10% of line speed. Below the Switch Point speed, the system runs in pressure control mode (PID control, in order to maintain the pressure set point). Above the Switch Point speed, the system runs in normal line speed following mode (utilizing the auto min and auto max parameters). The switch point value is displayed as programmed. Press the input field to edit the value.</p>
6	<p>Manual Setpoint (if in Manual Mode only) The manual setpoint RPM of the pump is displayed as programmed. Press the input field to edit the value.</p>
7	Press the arrow icon to go to the previous pump screen (i.e., Pump 1, etc.).
8	<p>Set the pump to the desired mode by pressing either MANUAL, OFF (STOP) or AUTO.</p> <ul style="list-style-type: none"> MANUAL: The pump speed is adjusted manually by the operator. If MANUAL is selected the icon is highlighted green. OFF (STOP): The pump is stopped, until AUTO or MANUAL is selected. If OFF is selected the icon is highlighted red. AUTO: The pump speed is controlled via a 0–10VDC signal that is provided by an external device (pattern control equipment or parent machine input). If AUTO is selected the icon is highlighted green. <p>A minimum speed is necessary to keep the pump turning in order to maintain a minimum amount of adhesive pressure through the hose and applicator head. For instance, if the input signal is 10VDC at 100 meters per minute and the pump percentage of full speed is 100% (maximum speed), but the system is putting out too much adhesive, adjusting the MAX pump percentage to 50 will cause the pump to slow down over the parent machine's entire speed range and adhesive output will be decreased.</p>
9	<p>Settings Button Press this button to go to the Extended Pump Mode Settings screen where you can select the Current Pump Mode "Linear Line Speed" or "Pressure Control" and you can go to the "Automatic Ramp Compensation" screen.</p>
10	Press the arrow icon to go to the next pump screen (i.e., Pump 3, etc.).
11	<p>BACK Button Press to return to the previous screen.</p>
12	LINE SPEED: The actual (or calculated) line speed is displayed.
13	<p>PRESSURE: The actual pressures are displayed. The primary pressure input can be controlled via the Pressure Set Point (point 3) set on this screen. The secondary pressure input is just a readout function. See explanation under Main Screen point 4.</p>
14	SPEED: The actual (or calculated) pump speed is displayed.

5.8.4 Automatic Ramp Compensation

- To go to this screen, press the Automatic Ramp Compensation button on the Extended Pump Mode Settings Linear Line Speed screen.
- The Automatic Ramp Compensation screen allows you to program parameters in order to compensate the adhesive amount when the speed of the main machine accelerates and decelerates.

With Linear Pump Control (Line Speed without Pressure PID Loop):

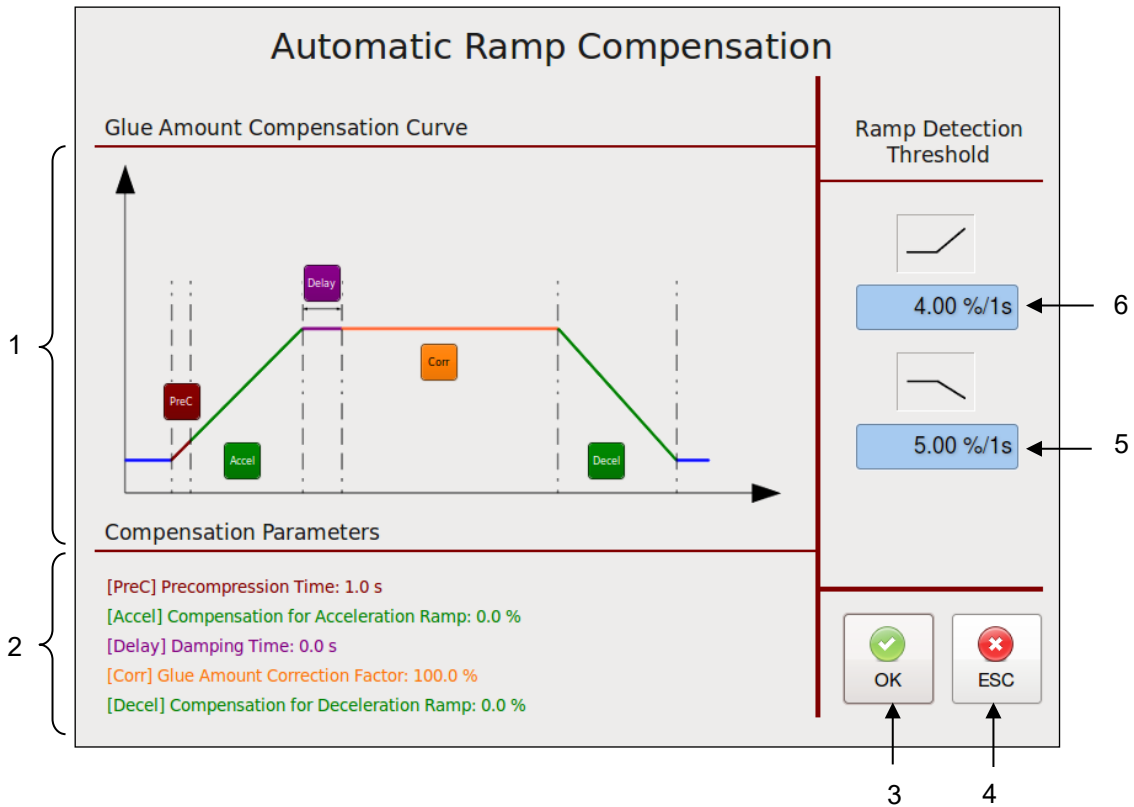

With Pressure Control PID Loop:

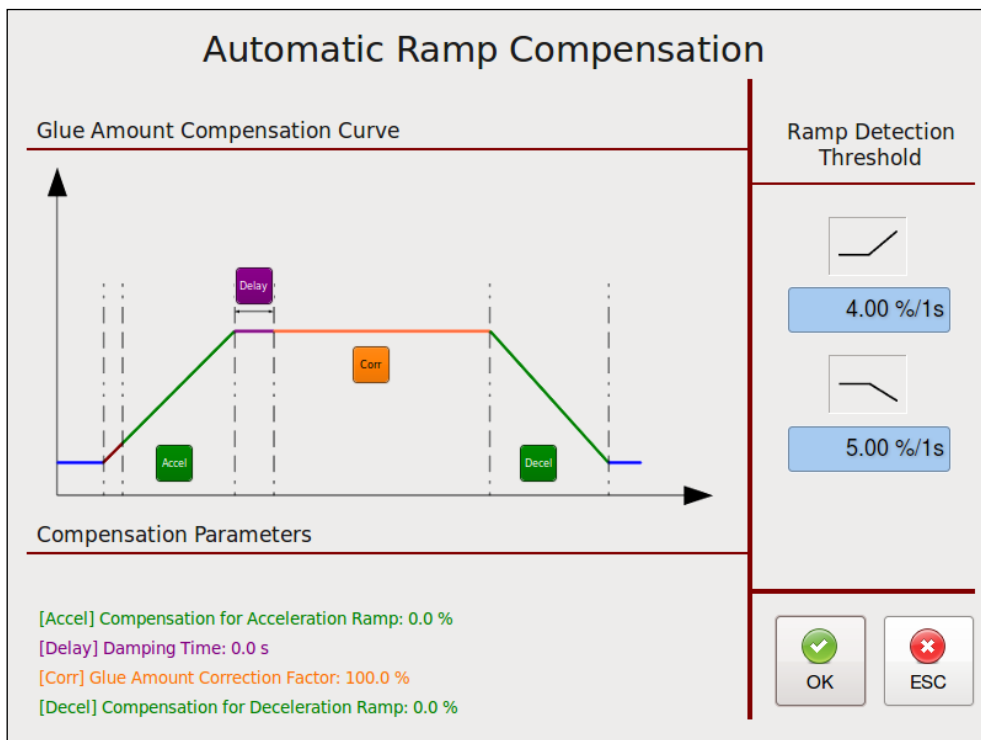

- Ramp Compensation allows tuning of adhesive amounts during acceleration and deceleration of main machine to reduce waste and increase machine efficiency by entering appropriate parameters.
- The colored parameters are related to the different phases of the main machine (see colored graph). A higher value will result in a higher compensation (more glue amount during acceleration, less glue amount during deceleration).
- After setting parameters by visibly checking the product result, further fine tuning might be necessary by checking products from the acceleration/deceleration ramp in a lab.

Item	Description
1	<p>Glue Amount Compensation Curve</p> <ul style="list-style-type: none"> • (PreC) Precompression Time in seconds: When using ramp compensation without pressure control loop, this defines the time the system will pre-compress at 75% pump speed before adhesive application. • (Accel) Compensation for Acceleration Ramp in % or rpm: This is the added percentage or rpm of pump speed to compensate the main machine acceleration ramp. • (Delay) Damping Time in seconds: within this time the compensation is reduced to the normal application rate in order to prevent an elastic impact. • (Corr) Glue Amount Correction Factor in %: Allows an adjustment of pump speed if a speed correction is required due to measured deviations of the adhesive amount. • (Decel) Compensation for Deceleration Ramp: This is the subtracted percentage or rpm of pump speed to compensate the main machine deceleration ramp. <p>By pressing the appropriate button, you can edit the value by means of numeric entry keypad.</p>
2	<p>Compensation Parameters</p> <p>The compensation parameters values currently in use are displayed.</p>
3	Press the OK button to confirm your entered values and return to the previous screen.
4	Press the ESC button to discard any non-confirmed values and return to the previous screen.
5	<p>Ramp Detection Threshold for deceleration in %/1s</p> <p>A main machine deceleration phase is automatically detected when its speed change lies above the given value.</p> <p>By pressing the input field, you can edit the value by means of numeric entry keypad.</p>
6	<p>Ramp Detection Threshold for acceleration in %/1s</p> <p>A main machine acceleration phase is automatically detected when its speed change lies above the given value.</p> <p>By pressing the input field, you can edit the value by means of numeric entry keypad.</p>

5.9 Control Switch On/Off and Standby Switch

- To go to this screen, press the Control button on the Main Screen.
- This screen allows you to turn the system On or Off and to activate/deactivate standby condition.

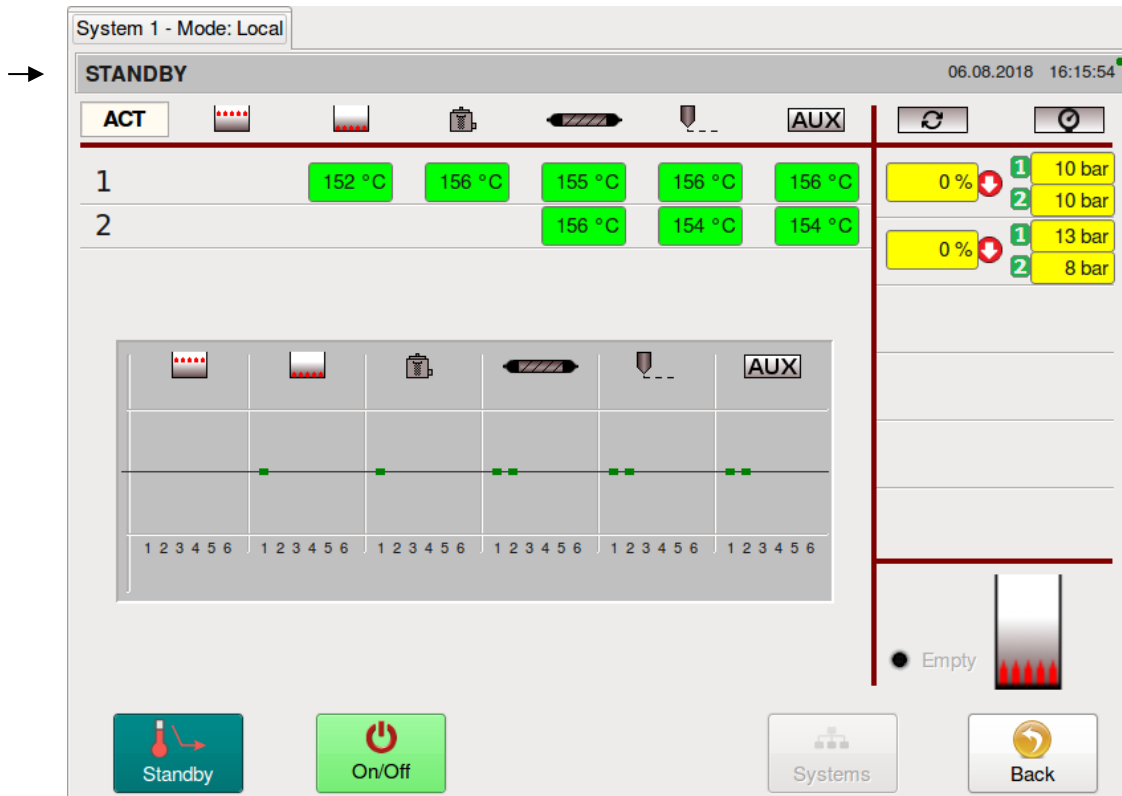

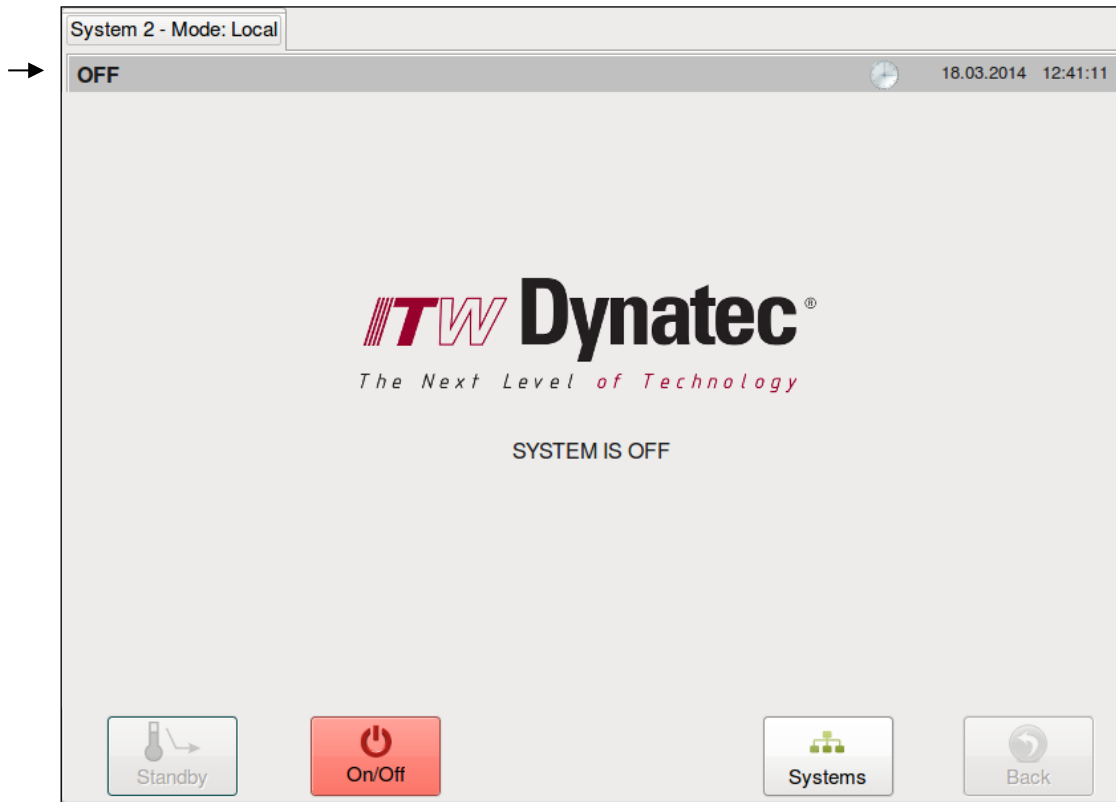

Item	Description
1	<p>Standby Switch</p> <ul style="list-style-type: none"> Press the Standby switch to activate or deactivate the standby condition. When Standby is activated, the button will be highlighted blue. When Standby is activated, all zone temperatures will be set to the standby value (programmed on the General Settings Screen) and all pumps will be disabled.
2	<p>On/Off Switch</p> <p>Press the On/Off button to toggle the system On or Off. When the system is On, the button will be highlighted green. When the system is Off, the button will be highlighted red.</p>
3	<p>BACK Button</p> <p>Press to return to the previous screen.</p>

5.10 Systems Screen

- To go to this screen, press the Systems button on the Main Screen.
- This screen displays all attached systems and allows you to select the desired system to control it.

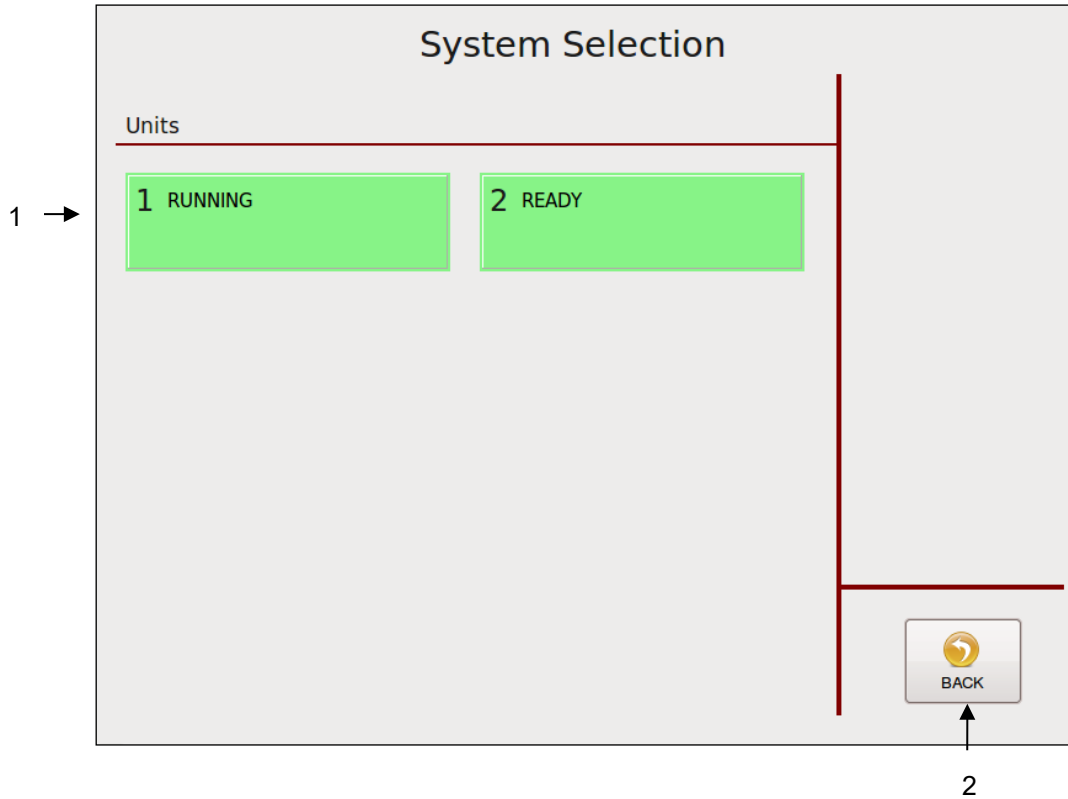

- For example: System #2 is selected. The system # will be indicated over the Status Line.

System #	Temp 1 (°C)	Temp 2 (°C)	Temp 3 (°C)	Temp 4 (°C)	Temp 5 (°C)	Temp 6 (°C)	Pressure (bar)
1	125	128	125	129	126	127	10
2	126	126	125	125	126	127	10
3				134	135	136	13
4				129	130	130	8
5				129	130	127	
6				128	129	125	
7				137	130	138	
8				128	128	128	

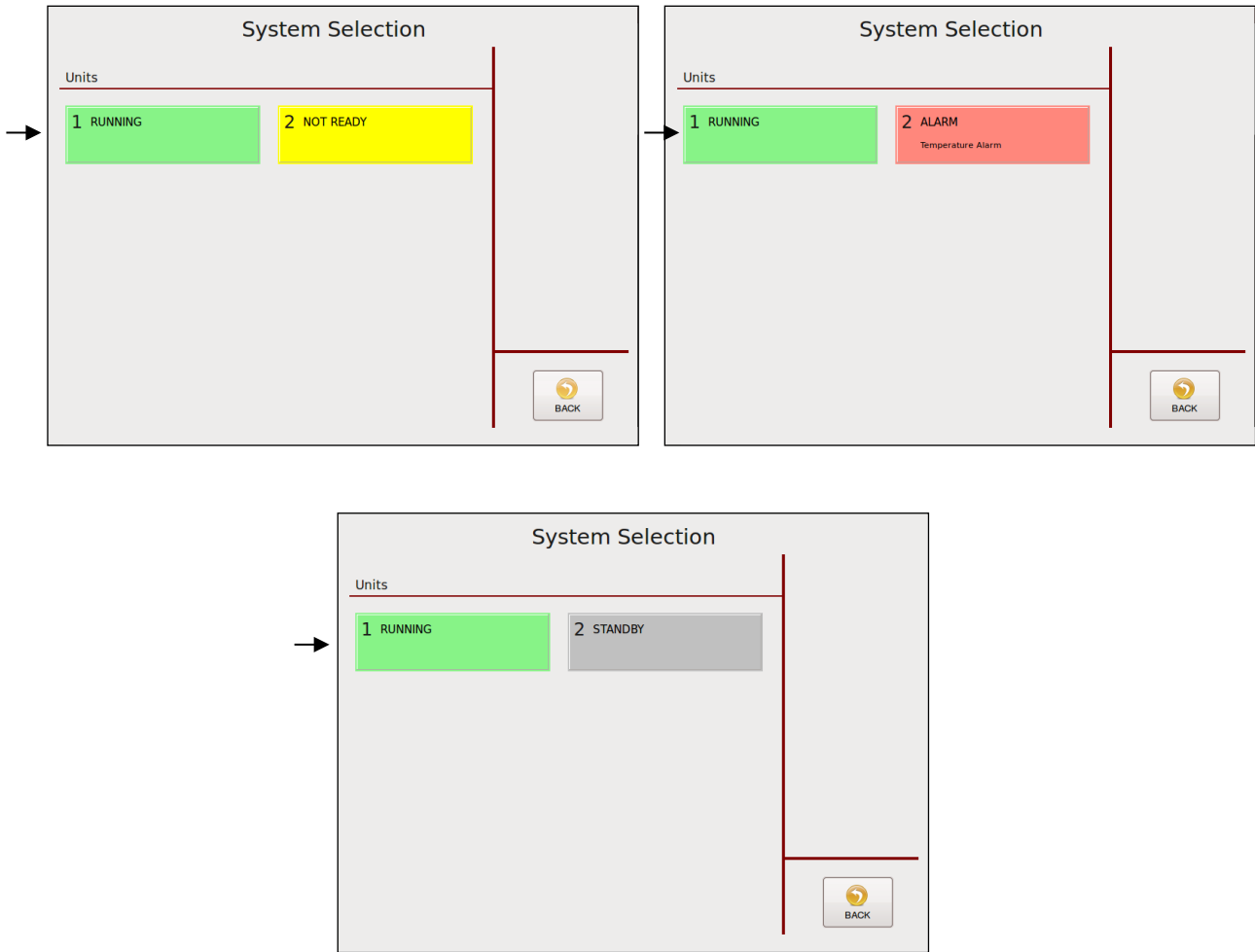

Item	Description
1	<p>System # Button</p> <ul style="list-style-type: none"> Each system is assigned with a number. Press the desired number to go to the appropriate system to control and to edit its parameters. The button is highlighted <u>green</u> when the system is RUNNING or READY, <u>yellow</u> when NOT READY, <u>grey</u> when in STANDBY and <u>red</u> when in ALARM condition.
2	<p>BACK Button</p> <p>Press to return to the previous screen.</p>

5.11 Settings Screen

- To go to this screen, press the Settings button on the Main Screen.
- This screen allows you to set the parameters displayed: Language, Temperature/ Pressure Units, Pump Setpoints, Heating Priority, Fieldbus, Recipes, Log Book, System Info (to see information about the controller and modules installed), Zone Configuration, General Settings (including Temperature Settings, Standby Settings, Level Control Settings, Pressure Calibration, Customer Zone Names and Support), XIO Settings, Time Scheduler and Security.

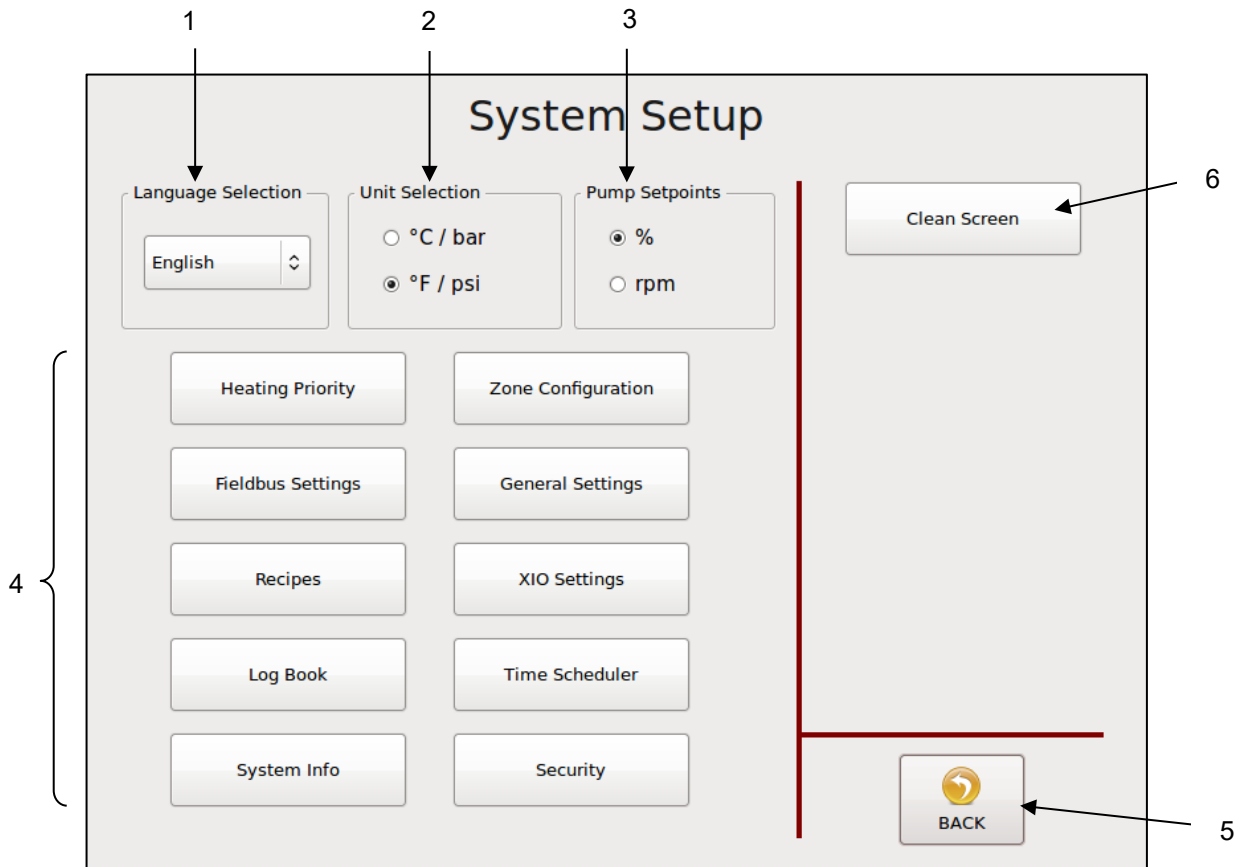

Item	Description
1	Language Selection Menu The current language is displayed. Press the button to select any language from the ones listed on the menu.
2	Unit & Date Selection Select the unit of temperature and pressure: choose either °C and bar or °F and psi. Depending on the selection made, the appearance of the date display is affected also. With the C/bar selection, the date is displayed as 'day.month.year' while in F/psi mode, the date is displayed as 'month/day/year'.
3	Pump Setpoints Select the pump speed setpoints either in RPM or % of production line speed.
4	All other Setting Buttons <ul style="list-style-type: none"> • To go to a desired screen, press the appropriate button. • On the following pages each screen is explained except XIO Settings. • XIO Settings: The screens used under XIO Settings are dependent from integrated equipment. See separate add-on at the end of this chapter.
5	BACK Button Press to return to the previous screen.
6	Clean Screen Button Press this button to clean the screen. Then, the functions of the Touch Panel will be switched off for 20 seconds.

5.11.1 Heating Priority Screen

- To go to this screen, press the Heating Priority button on the Settings Screen.
- This screen allows you to set a Heating Priority for each zone. Heating Priority allows the hopper zones to heat to their ready temperatures before the other zones begin heating. In this way, the larger mass of adhesive in the hopper zones (including the grid, hopper and filter manifold) gets a head start on the other zones (hoses, applicators and auxiliary zones).

Heating Priority Matrix Example:

Zone	Icon 1	Icon 2	Battery	Hose	Nozzle	AUX
1	PRIO 1 125°C	PRIO 1 129°C	PRIO 1 126°C	PRIO 2 125°C	PRIO 3 125°C	PRIO 3 127°C
2	PRIO 1 126°C	PRIO 1 127°C	PRIO 1 125°C	PRIO 2 125°C	PRIO 3 126°C	PRIO 3 127°C
3				PRIO 2 124°C	PRIO 3 125°C	PRIO 3 126°C
4				PRIO 2 129°C	PRIO 3 126°C	PRIO 3 126°C
5				PRIO 2 128°C	PRIO 3 130°C	PRIO 3 127°C
6				PRIO 2 128°C	PRIO 3 129°C	PRIO 3 127°C
7						
8						
9						
10						
11						
12						



Item	Description
1	Touch each zone field to select one of the following three Heating Priorities, or to switch the zone OFF: <ul style="list-style-type: none"> • PRIO1 = the zone will heat first. • PRIO2 = the zone will begin to heat after the PRIO1 zones have reached their setpoints. • PRIO3 = the zone will begin to heat after the PRIO2 zones have reached their setpoints. • OFF = the zone is OFF. It will not heat and it will not be displayed on the Main screen.
2	Press the OK button to confirm your entered values and return to the previous screen.
3	Press the ESC button to discard any non-confirmed values and return to the previous screen.
4	Press the Standard Sequence button to accept the following standard Heating Priorities: <ul style="list-style-type: none"> • PRIO1 = grid, hopper and filter manifold • PRIO2 = hoses • PRIO3 = applicators and other auxiliary components Press the OK button to confirm.
5	Press the Without Sequence button to assign all zones to PRIO1. With this setting, all zones will begin to heat after turning on the unit. Press the OK button to confirm.

5.11.2 Zone Configuration Screen

- To go to this screen, press the Zone Configuration button on the Settings Screen.
- This screen allows you to enter zone names and to set Offset Temperature and other Control Settings for each zone.

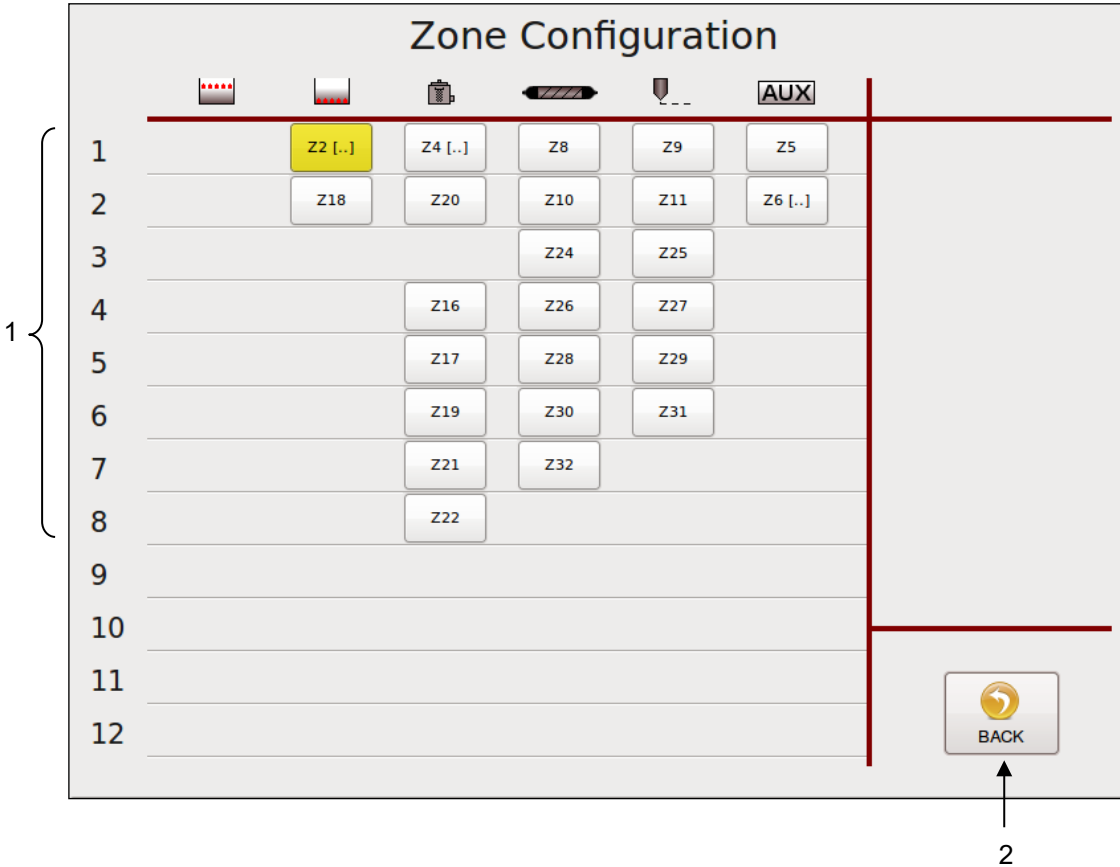
Zone Configuration Screen Example:





Item	Description
1	<ul style="list-style-type: none"> • Touch a zone input box to go to the Zone Settings. •  Zone is highlighted yellow if an Offset Temperature has been set for this zone. •  Square bracket is displayed if a custom zone name has been entered for this zone.
2	<p>BACK Button Press to return to the previous screen.</p>

5.11.3 Zone Settings

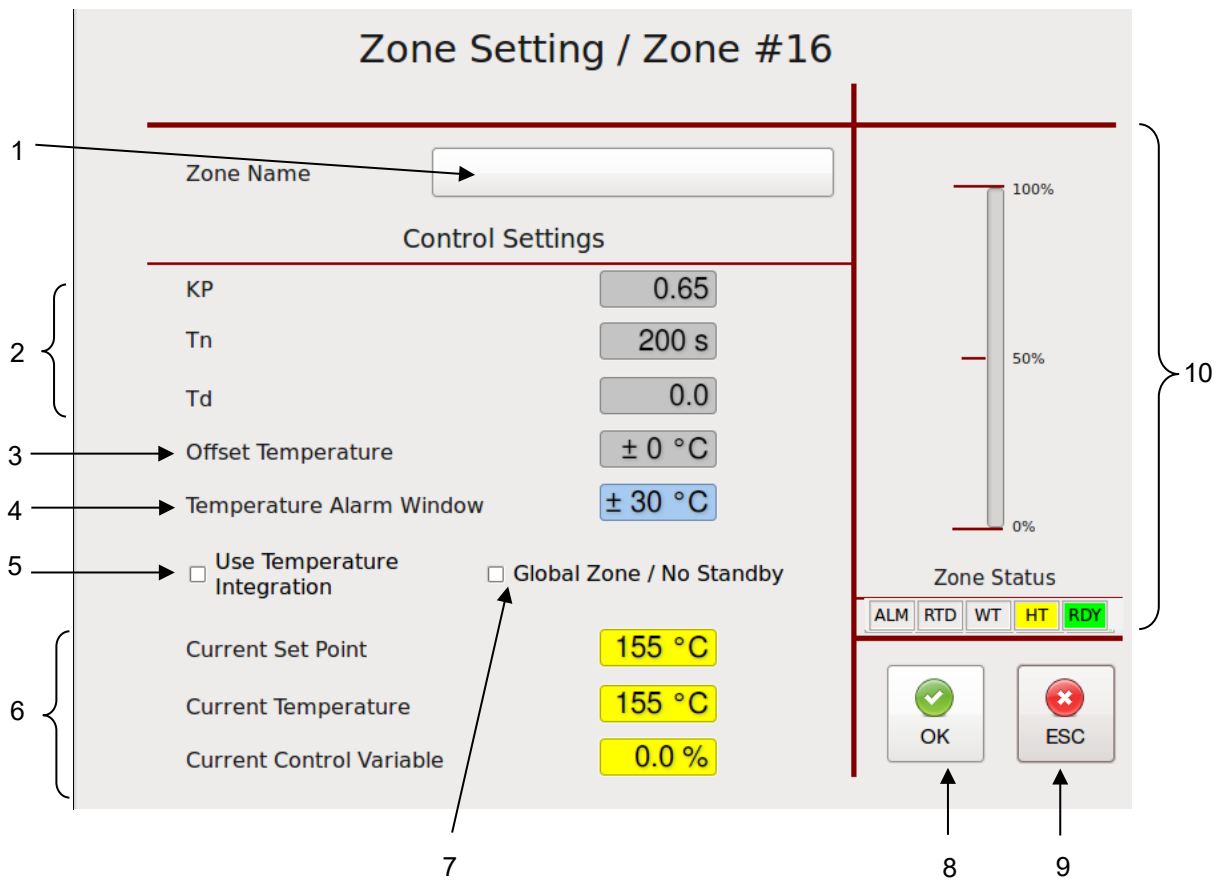
➤ To go to this screen, press a zone input box on the Zone Configuration Screen.



Item	Description
1	Zone Name Touch the input box and an Alphabetic Entry Keypad will appear. Enter your desired name and confirm by pressing OK.
2	Control Settings <ul style="list-style-type: none"> • KP, Tn and Td values allow access to the control parameters of PID Controller of the selected zone. • These values can be changed only by using a Maintenance password. See Security screen.
3	Offset Temperature <ul style="list-style-type: none"> • Temperature Offsets are mathematical factors which compensate for differences in temperature within components. Each temperature zone may be programmed with an offset, if desired. Standard equipment does not usually require temperature offsets. <p>Note: Entering a positive-numbered offset will raise the temperature reading of that zone. Since the controller attempts to equate setpoint and actual temperature, this lowers the actual temperature by the amount of the offset.</p> <p>For example: setpoint and actual temperature both equal 150°C (302°F). An offset of +10°C (+10°F) is programmed. Initially the display will read 160°C (312°F), but the controller will lower the output power until the actual temperature value is back to 150°C (302°F).</p> <ul style="list-style-type: none"> •  Warning icon is displayed if an Offset Temperature has been set for the zone. • This value can be changed only by using a Maintenance password. See Security screen.

Item	Description
4	<p>Temperature Alarm Window Here you can define a separate alarm window for this zone.</p> <p>If you do this, this will be indicated by an  in the General Settings / Temp Settings window.</p>
5	<p>Use Temperature Integration</p> <ul style="list-style-type: none"> • Depending on your Temp Module this function can be activated/ deactivated. • If you experience strong variations in actual temperature read-out, an integration function can be activated to eliminate EMC influence.
6	<p>These values are read-only.</p>
7	<p>Global Zone / No Standby The function is set individually for each zone. When this function is activated, the zone is defined as a "Global Zone". Global zones are not covered by the temperature reduction (standby) if the unit is switched to standby mode; i.e. even in standby mode, the "global zones" will continue to heat up to the set setpoint temperatures, while the other zones are reduced by the set standby difference.</p>
8	<p>Press the OK button to confirm your entered values and return to the previous screen.</p>
9	<p>Press the ESC button to discard any non-confirmed values and return to the previous screen.</p>
10	<p>Zone Status Zone status is indicated.</p> <ul style="list-style-type: none"> • ALM = is highlighted if zone has an alarm. • RTD = is highlighted if temperature sensor error occurs. • WT = is highlighted if zone is in wait status because of heating priority setting. • HT = is highlighted if zone is heating up. • RDY = is highlighted if zone ready (setpoint temperatures are reached). • Scale = Indication of Current Control Variable of the selected PID control zone.

5.11.4 Fieldbus Setup Screen

- To go to this screen, press the Fieldbus Settings button on the Settings Screen.
- When communicating to a parent machine which utilizes Profibus or EtherNet IP, the unit must have a Fieldbus Address to identify it. When there are additional units in a system, each unit must have its own unique Fieldbus Address.

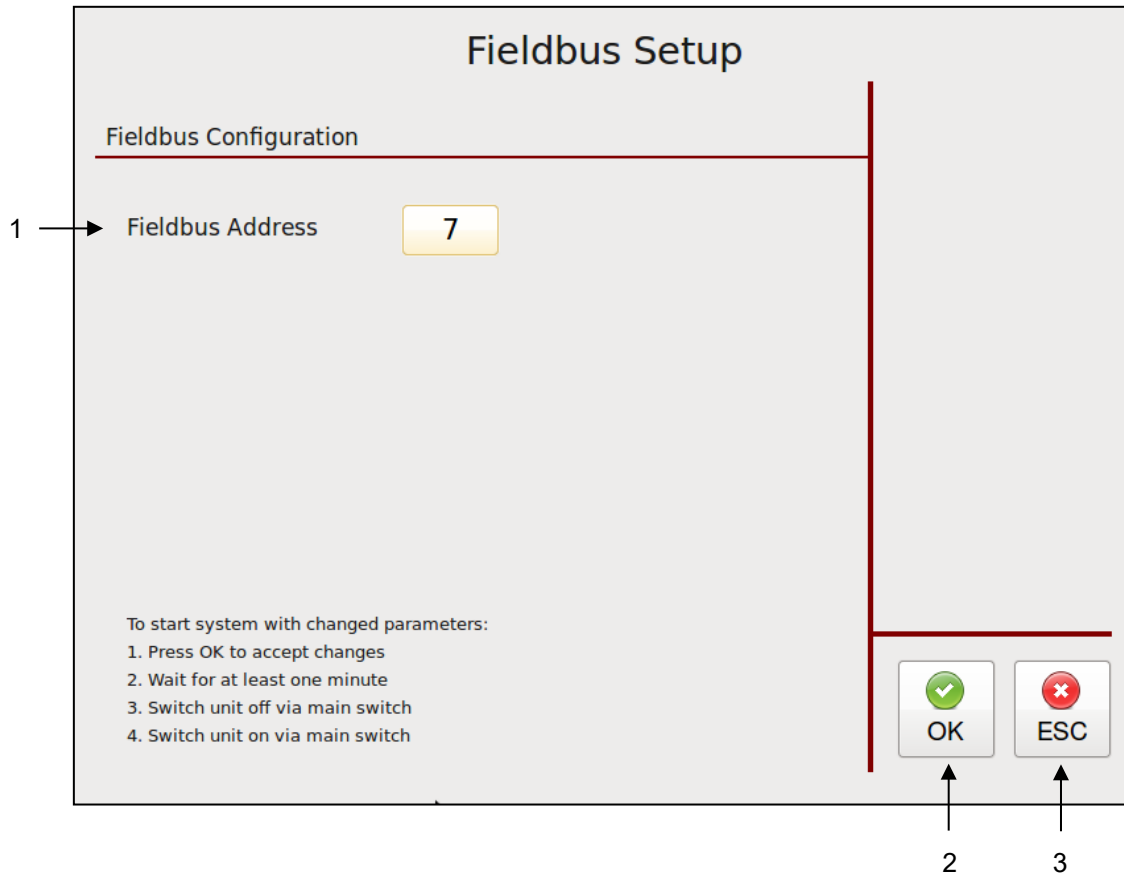

Item	Description
1	<p>Fieldbus Address Touch the input box and a numeric entry keypad will appear. Enter the Fieldbus Address of the unit. Confirm by pressing OK.</p> <p>After programming the Fieldbus Address, the system must be re-started. To re-start the system with changed parameters: 1. Press OK to accept changes. 2. Wait at least one minute. 3. Switch unit Off via the main switch. 4. Switch unit On via the main switch.</p>
2	Press the OK button to confirm your entered values and return to the previous screen.
3	Press the ESC button to discard any non-confirmed values and return to the previous screen.

5.11.5 General Settings Screen

- To go to this screen, press the General Settings button on the Settings Screen.
- This screen allows you to set the parameters shown across the screen's top line (Item #1, shown below).
- Select a desired parameter (Temperature, Standby, Level Control, Pressure Calibration or Customer Zone Names) by pressing its tab or by pressing the arrows at the bottom of the screen.

5.11.5.1 Temperature Settings

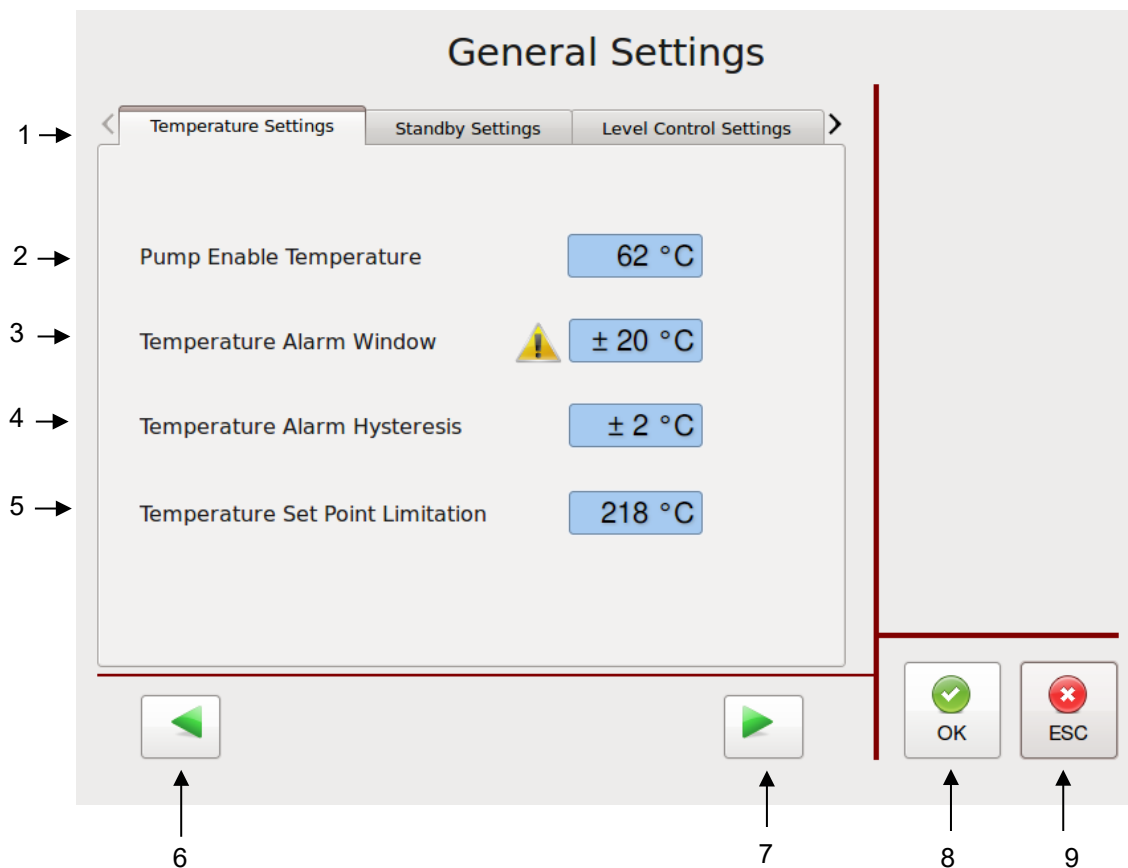

Item	Description
1	Parameter Selection tabs The Temperature Settings tab has been selected.
2	Pump Enable Temperature <ul style="list-style-type: none"> • The Pump Enable Temperature is a low-limit value (e.g. 100°C / 212°F) which protects the pump, pump shaft, motor and motor control module by preventing the pump from turning on until a minimum adhesive temperature is achieved. Caution should be taken to avoid setting this value too low because attempting to rotate the pump when the adhesive inside it is not molten will result in damage to the pump and, possibly, to the pump motor. The Pump Enable Temperature is independent from the temperature setpoints. The programmable range is 10-200 °C (50- 400°F). • Touch the input box and a numeric entry keypad will appear. Enter your desired Pump Enable Temperature value and confirm by pressing OK.

Item	Description
3	<p>Temperature Alarm Window</p> <ul style="list-style-type: none"> The displayed value is from zone 1.  This indicates that other zones have a different alarm window. <ul style="list-style-type: none"> This is the programmable temperature range which allows the unit to go into Ready condition. The Temperature Alarm Window is a deviation (e.g. $\pm 20^{\circ}\text{C}$ / 36°F) from the setpoint. The setpoint minus the deviation is the low limit of the window, and the setpoint plus the deviation is the high limit of the window. The programmable range is $0\text{-}50^{\circ}\text{C}$ ($0\text{-}90^{\circ}\text{F}$). The Temperature Alarm Window (\pm the Temperature Alarm Hysteresis, if programmed) will trigger high and low temperature alarms when zone temperatures rise or fall outside of the window. Touch the input box and a numeric entry keypad will appear. Enter your desired Temperature Alarm Window value and confirm by pressing OK.
4	<p>Temperature Alarm Hysteresis</p> <ul style="list-style-type: none"> This is a second, smaller, temperature range and alarm limit programmed in addition to the Temperature Alarm Window which allows the unit to remain in Ready condition as temperatures stabilize. The Temperature Alarm Hysteresis is a deviation (e.g. $\pm 2^{\circ}\text{C}$ / 3°F) from the Temperature Alarm Window. The Temperature Alarm Window minus the deviation is the low limit of the Temperature Alarm Hysteresis, and the Temperature Alarm Window plus the deviation is the high limit of the Temperature Alarm Hysteresis. The programmable range is $0\text{-}10^{\circ}\text{C}$ ($0\text{-}30^{\circ}\text{F}$). The Temperature Alarm Hysteresis will trigger high and low temperature alarms when those temperatures are exceeded. Touch the input box and a numeric entry keypad will appear. Enter your desired Temperature Alarm Hysteresis value and confirm by pressing OK.
5	<p>Temperature Set Point Limitation</p> <p>This is a by customer programmable maximum temperature set point limitation.</p>
6	Press the left-pointing arrow to go to the previous General Settings screen.
7	Press the right-pointing arrow to go to the next General Settings screen.
8	Press the OK button to confirm your entered values and return to the previous screen.
9	Press the ESC button to discard any non-confirmed values and return to the previous screen.

5.11.5.2 Standby Settings

➤ To go to this screen, press the General Settings button on the Settings Screen.

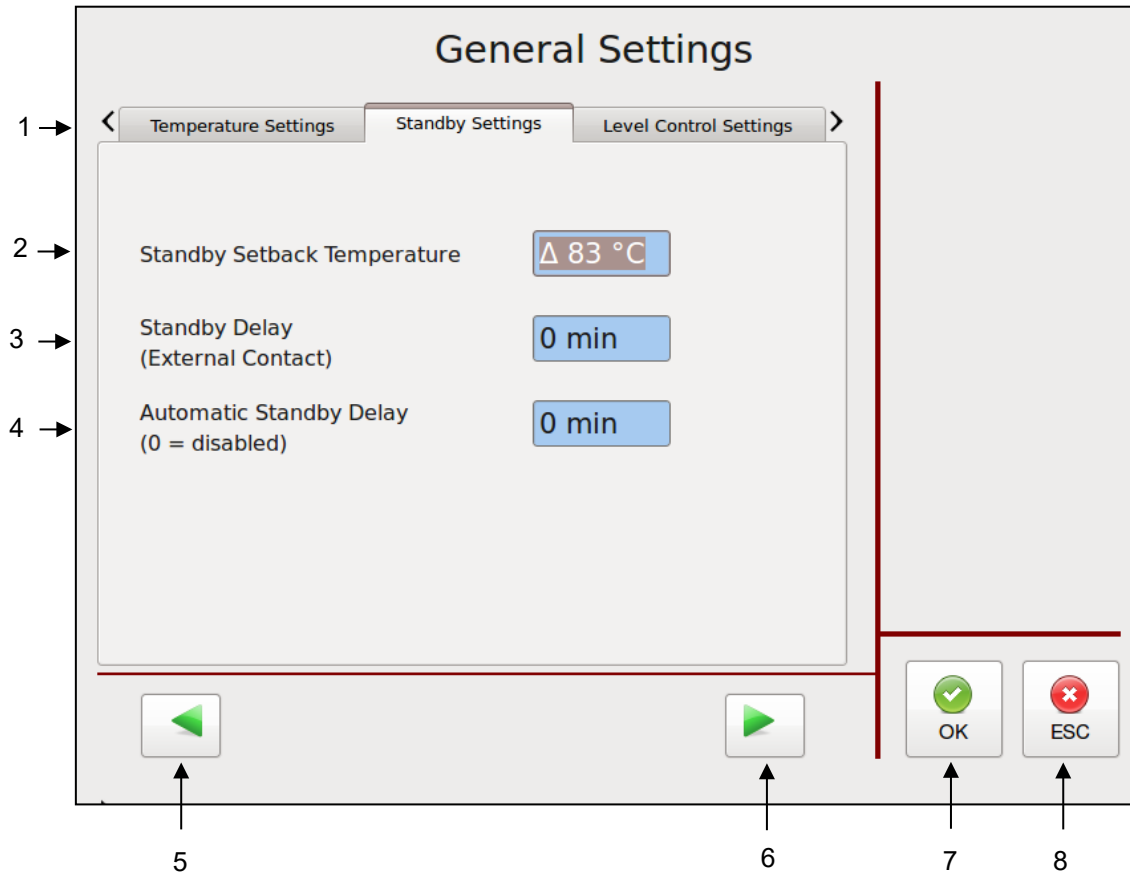

Item	Description
1	Parameter Selection tabs The Standby Settings tab has been selected.
2	Standby Setback Temperature <ul style="list-style-type: none"> This is the system condition where the hopper, hose and head temperatures are maintained at predetermined reduced temperature values. Standby Setback Temperatures are set lower than setpoint temperatures (e.g. 83°C / 149°F) in order to reduce adhesive degradation and energy consumption when the system is temporarily inactive, and to permit rapid system warm-up when run conditions are selected. When standby mode is activated, the controller will display STANDBY. The programmable range is 0-150 °C (0-270°F). Touch the input box and a numeric entry keypad will appear. Enter your desired Standby Setback Temperature value and confirm by pressing OK.
3	Standby Delay (External Contact) <ul style="list-style-type: none"> The Standby Delay is the programmed number of minutes until the unit goes into standby mode after activation by an external contact (for example: a PLC or an external switch). The programmable range is 0-150 minutes. Touch the input box and a numeric entry keypad will appear. Enter your desired Standby Delay value and confirm by pressing OK.
4	Automatic Standby Delay (0 = disabled) <ul style="list-style-type: none"> The Automatic Standby Delay is the programmed number of minutes until the unit goes into standby mode after the unit has heated-up and the pump is stopped (no adhesive feeding activity). The programmable range is 0-1440 minutes. Enter 0 to disable the feature. Touch the input box and a numeric entry keypad will appear. Enter your desired Automatic Standby Delay value and confirm by pressing OK.

<i>Item</i>	<i>Description</i>
5	Press the left-pointing arrow to go to the previous General Settings screen.
6	Press the right-pointing arrow to go to the next General Settings screen.
7	Press the OK button to confirm your entered values and return to the previous screen.
8	Press the ESC button to discard any non-confirmed values and return to the previous screen.

5.11.5.3 Level Control Settings

➤ To go to this screen, press the General Settings button on the Settings Screen.

If Digital Level Sensor is installed:

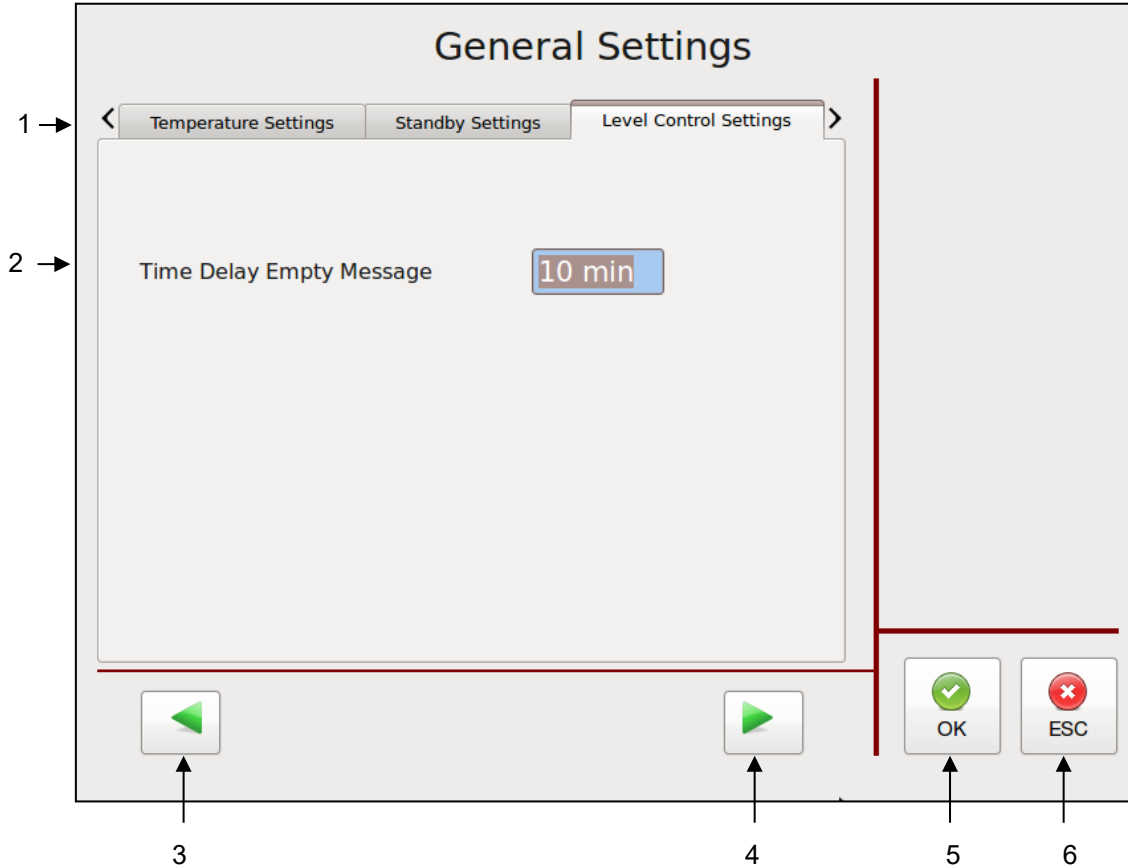

Item	Description
1	Parameter Selection tabs The Level Control Settings tab has been selected.
2	Time Delay Empty Message <ul style="list-style-type: none"> This is a programmable time delay for reappearance of the level control's Empty message. The level control device informs the operator via a "Minimum Level" message on the display that the hopper needs to be refilled. After expiration of the time delay, the message Minimum Level will be indicated on the display. The programmable range is 0-31 minutes. Touch a zone input box and a numeric entry keypad will appear and the values can be edited. Enter the value and confirm by pressing OK.
3	Press the left-pointing arrow to go to the previous General Settings screen.
4	Press the right-pointing arrow to go to the next General Settings screen.
5	Press the OK button to confirm your entered values and return to the previous screen.
6	Press the ESC button to discard any non-confirmed values and return to the previous screen.

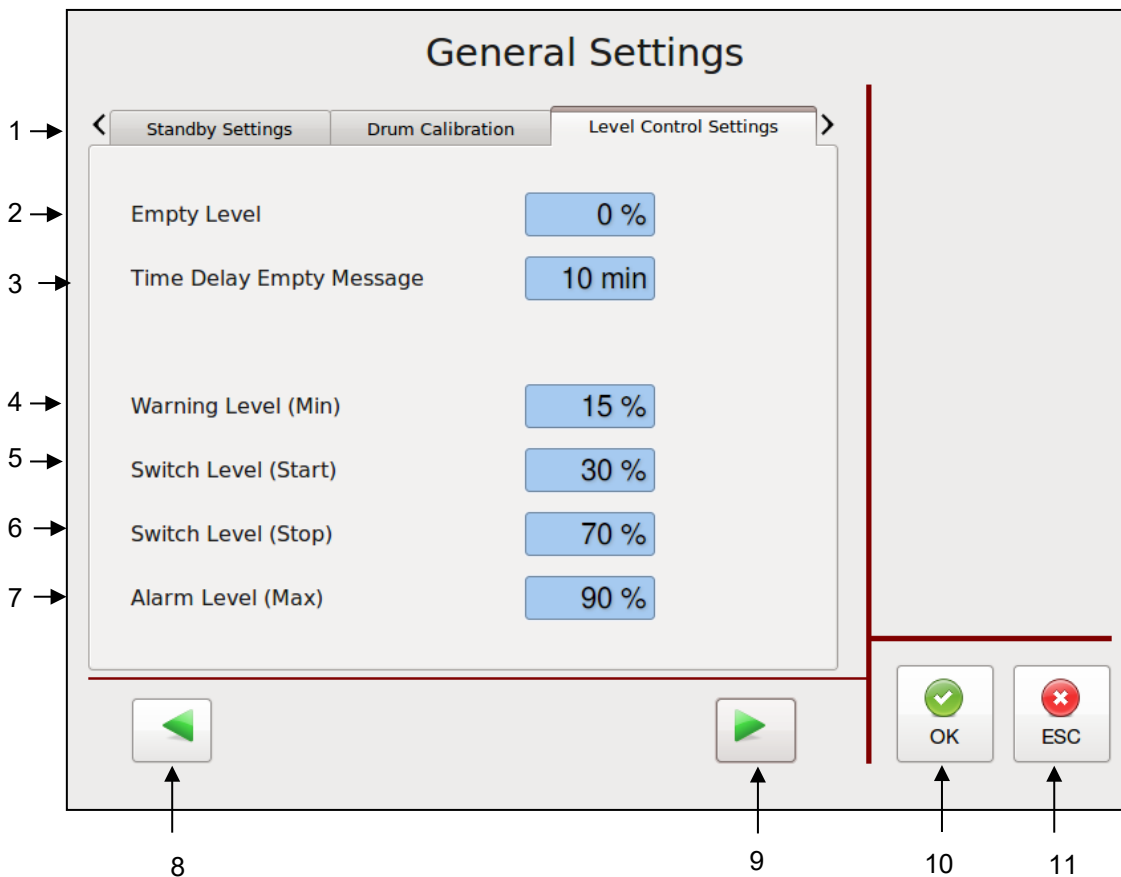
If Analog Level Sensor is installed:

Item	Description
1	Parameter Selection tabs The Level Control Settings tab has been selected.
2	Empty Level If fill level is lower than this parameter an empty message will be generated.
3	Time Delay Empty Message <ul style="list-style-type: none"> This is a programmable time delay for reappearance of the level control's Empty message. The level control device informs the operator via a "Minimum Level" message on the display that the hopper needs to be refilled. After expiration of the time delay, the message Minimum Level will be indicated on the display. The programmable range is 0-31 minutes. Touch a zone input box and a numeric entry keypad will appear and the values can be edited. Enter the value and confirm by pressing OK.
4	Warning Level (Min) Template-dependent parameter (not used in standard configuration).
5	Switch Level (Start) If system is configured as refiller control this parameter defines the refill start level.
6	Switch Level (Stop) If system is configured as refiller control this parameter defines the refill stop level.
7	Alarm Level (Max) Template-dependent parameter (not used in standard configuration).
8	Press the left-pointing arrow to go to the previous General Settings screen.
9	Press the right-pointing arrow to go to the next General Settings screen.
10	Press the OK button to confirm your entered values and return to the previous screen.
11	Press the ESC button to discard any non-confirmed values and return to the previous screen.

5.11.5.4 Pressure Zero Calibration

➤ To go to this screen, press the General Settings button on the Settings Screen.

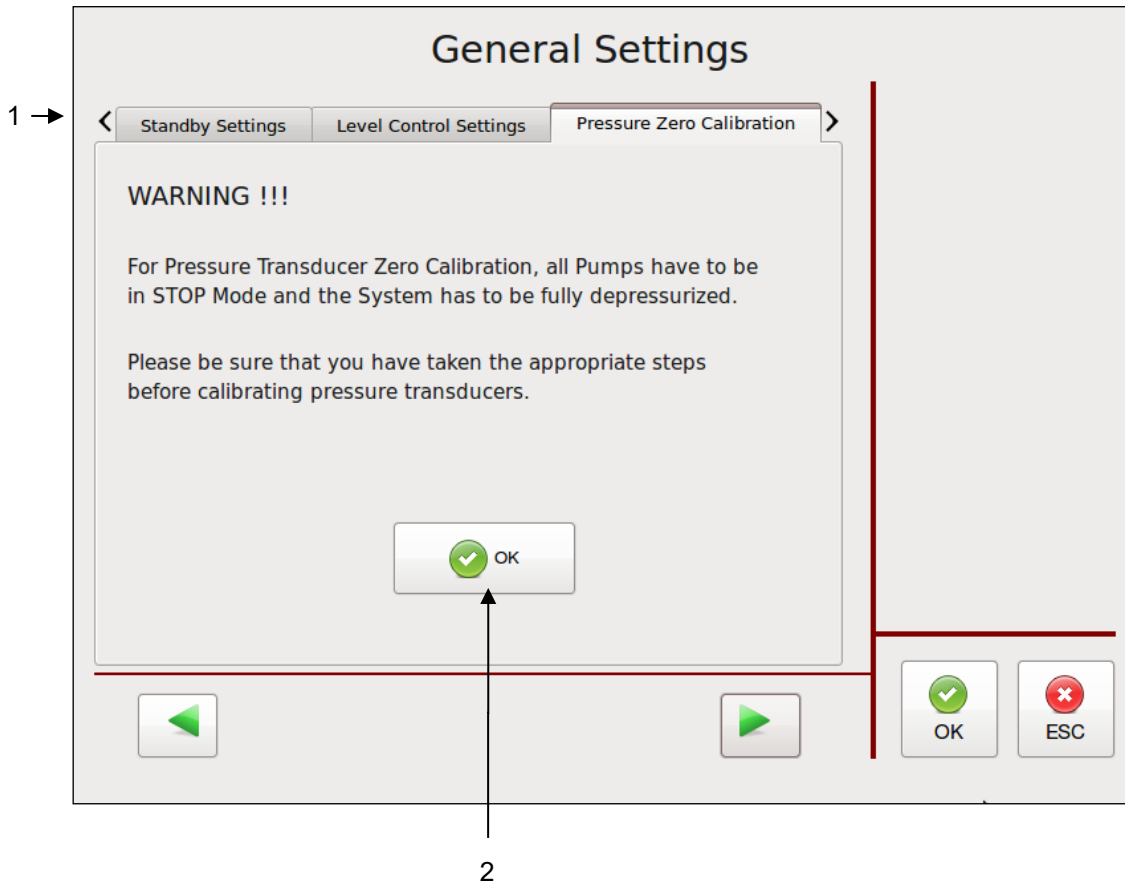

Item	Description
1	Parameter Selection tabs The Pressure Zero Calibration tab has been selected.
2	OK Button Before calibrating the (optional) pressure transducers, all pumps must be in STOP mode and the system must be fully depressurized. After taking the appropriate steps, confirm this by pressing the OK button. You will then go to the Calibrating Screen.

Calibrating Screen

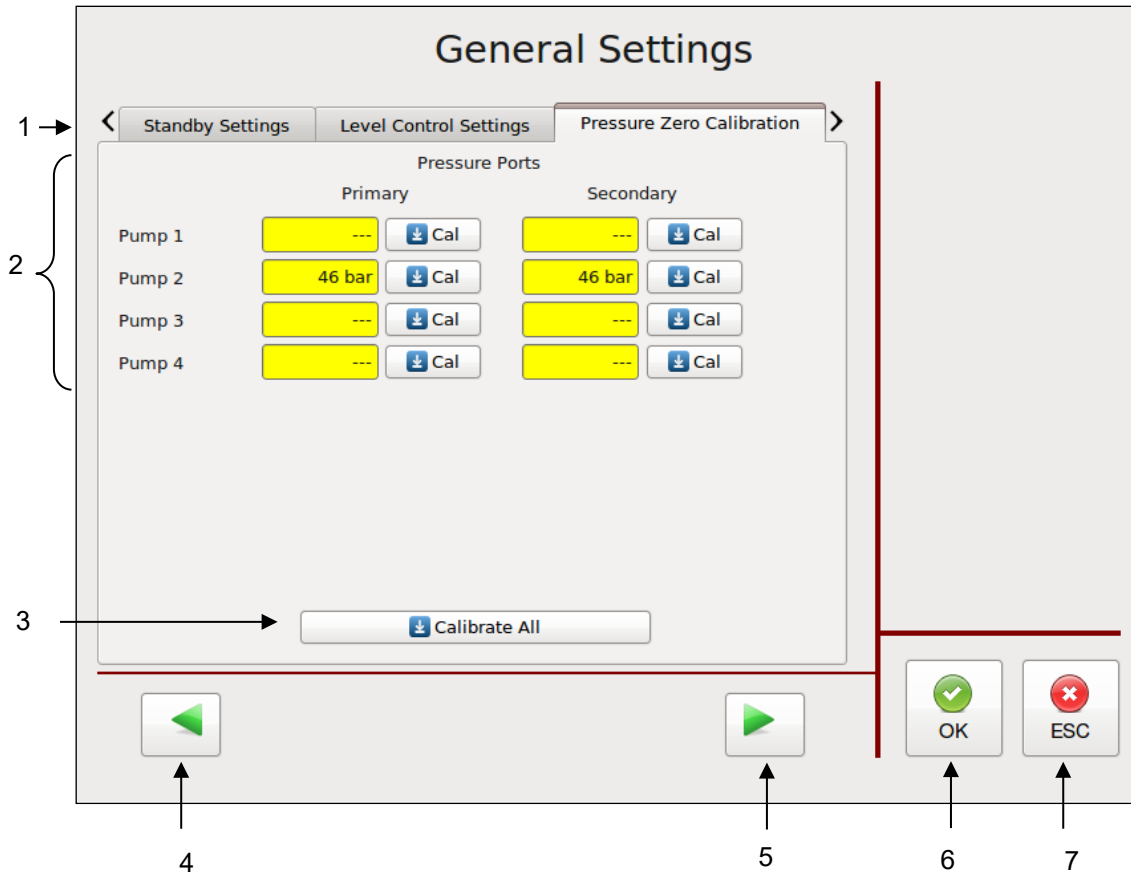

Item	Description
1	Parameter Selection tabs The Pressure Zero Calibration tab has been selected.
2	Pressure Zero Calibration If (optional) pressure sensors are installed on the unit, the pumps can be pressure controlled. Pressure values will be displayed on the Main Screen. Refer to Pump Control, Pressure Control. Primary and Secondary Pressure Ports are displayed on the screen. Calibrate each pump to zero by pressing the appropriate "Cal" button. Note: before calibrating pressure transducers, all pumps must be in STOP mode and the system must be fully depressurized.
3	Calibrate All Press the Calibrate All button to calibrate all pumps to zero at one time. Note: before calibrating pressure transducers, all pumps must be in STOP mode and the system must be fully depressurized.
4	Press the left-pointing arrow to go to the previous General Settings screen.
5	Press the right-pointing arrow to go to the next General Settings screen.
6	Press the OK button to confirm your entered values and return to the previous screen.
7	Press the ESC button to discard any non-confirmed values and return to the previous screen.

5.11.5.5 Customer Zone Names

- To go to this screen, press the General Settings button on the Settings Screen.
- Use the Customer Zone Names Editor program (provided on CD) and a thumb drive (not provided) to make changes.

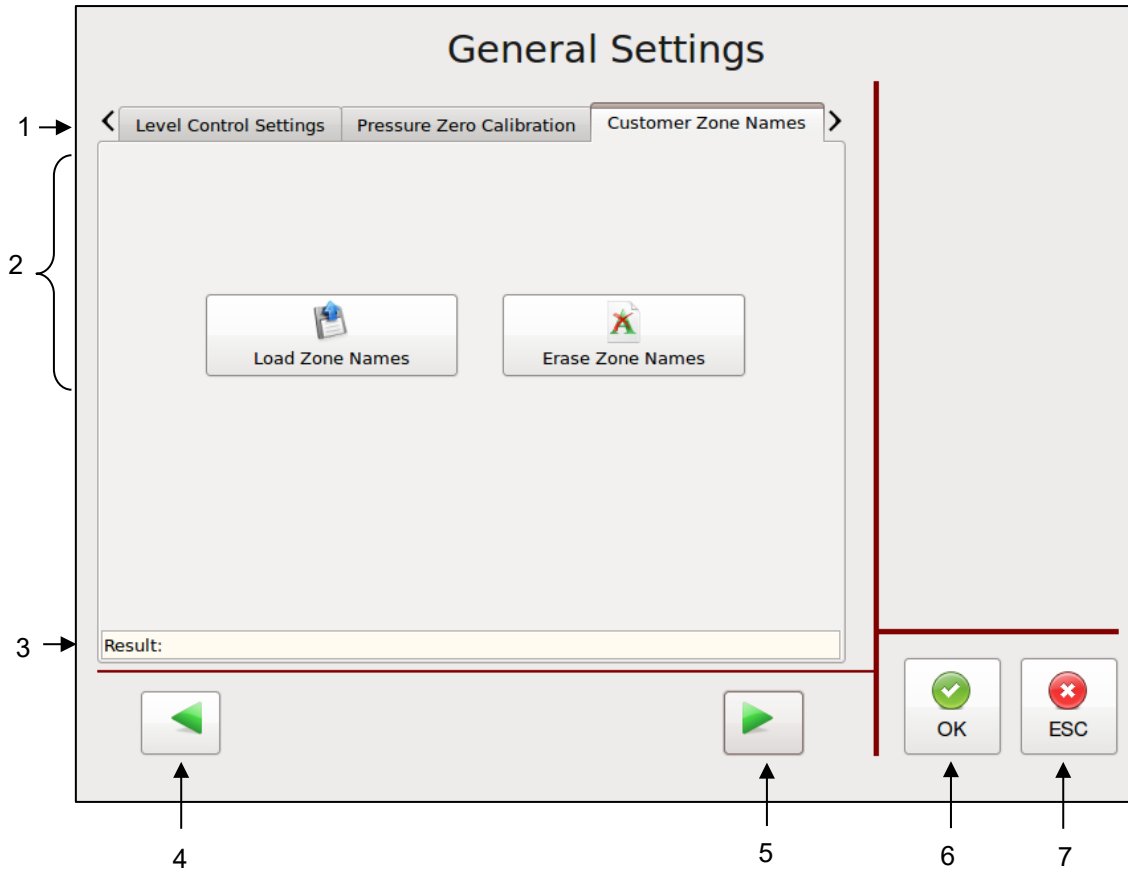

Item	Description
1	<p>Parameter Selection tabs The Customer Zone Names tab has been selected.</p>
2	<p>Customer Zone Names If activated, you can Load or Erase Zone Names by pressing the appropriate button. With the Customer Zone Names feature, the user may personalize the names of the temperature zones with names that are more descriptive for his application.</p> <p>A CD with the Customer Zone Names Editor program is supplied with your unit. The program allows the character sets of many different languages. To utilize this feature:</p> <ol style="list-style-type: none"> 1. Install the program from the CD into your computer. 2. Write your personalized zone names in this program. 3. Load your personalized program onto a thumb drive. 4. Insert the thumb drive into the V6 touch panel. 5. Load the new names into the controller by pressing “Load Zone Names” on the Customer Zone Names screen (seen above). 6. Activate the names by pressing “Activate Customer Zone Names”. <p>Later you may deactivate (or re-activate) the names by pressing “Activate Customer Zone Names” again. When personalized names are deactivated, the ITW Dynatec default zones names become active.</p> <p>You may also press Erase Zone Names to delete your loaded zone names and you may load a new group of names utilizing the Customer Zone Names Editor program again.</p>

<i>Item</i>	<i>Description</i>
3	Result A message will confirm if the names were successfully loaded, activated or deactivated, or if there was an error in loading the names.
4	Press the left-pointing arrow to go to the previous General Settings screen.
5	Press the right-pointing arrow to go to the next General Settings screen.
6	Press the OK button to confirm your entered values and return to the previous screen.
7	Press the ESC button to discard any non-confirmed values and return to the previous screen.

5.11.5.6 Support

- To go to this screen, press the General Settings button on the Settings Screen.
- Use the Customer Zone Names Editor program (provided on CD) and a thumb drive (not provided) to make changes.

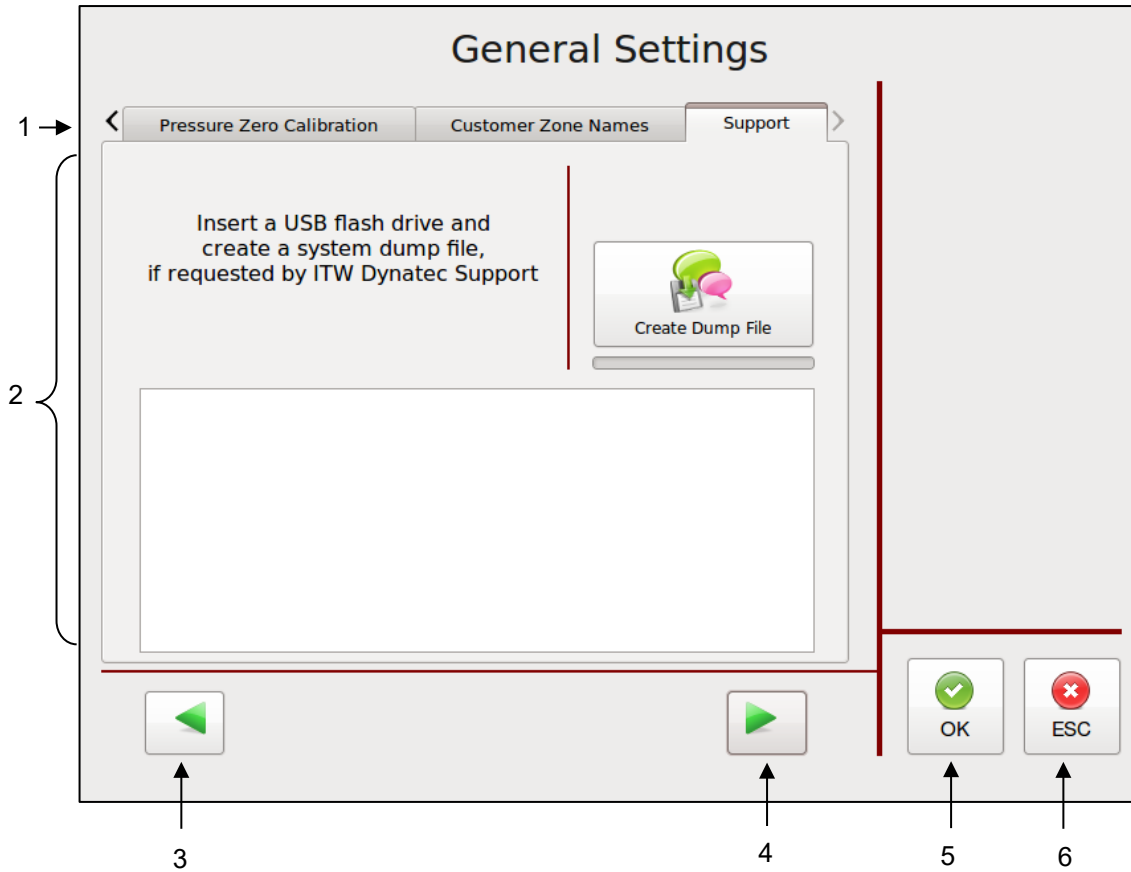



Item	Description
1	Parameter Selection tabs The Support tab has been selected.
2	If requested by ITW Dynatec Support, you can insert USB Flash Drive to create a system dump file. This file can be sent to ITW Dynatec for offline diagnostics.
3	Press the left-pointing arrow to go to the previous General Settings screen.
4	Press the right-pointing arrow to go to the next General Settings screen.
5	Press the OK button to confirm your entered values and return to the previous screen.
6	Press the ESC button to discard any non-confirmed values and return to the previous screen.

5.11.6 Recipes Screen

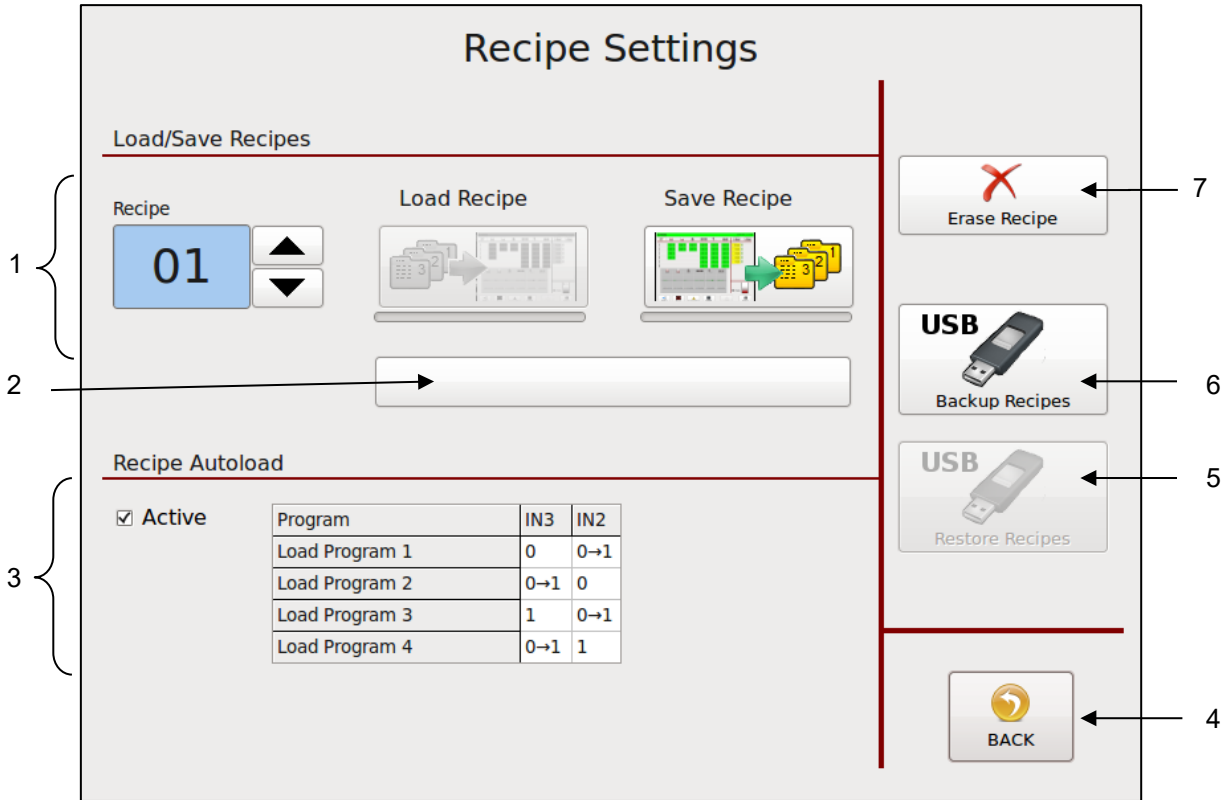
- To go to this screen, press the Recipes button on the Settings Screen.
- This screen allows you to create recipes (or “programs”). A recipe is a set of temperature set points and parameters which the user has programmed and stored in the controller for future use. Up to ten recipes may be stored in the V6 controller.



Item	Description
1	<p>To Create and Save a Recipe:</p> <ol style="list-style-type: none"> 1. Program the controller as you wish it to be setup for a recipe. Program the following parameters: temperature settings, zone On/Off settings, motor mode and speed. 2. Using the up and down arrows, select a number to assign to your recipe. 3. Press “Save Recipe”  button. The recipe will be saved. <p>To Load a Saved Recipe:</p> <ol style="list-style-type: none"> 1. Using the up and down arrows, select a recipe number. 2. Press the “Load Recipe”  button. The recipe will be loaded, and the saved parameters will be set.
2	<p>Recipe Name</p> <p>Touch the input box and an Alphabetic Entry Keypad will appear. Enter your desired name and confirm by pressing OK.</p>
3	<p>Recipe Autoload</p> <p>This function may be activated or deactivated by pressing the Active button. If activated, up to four recipes (always the first four saved recipes) can be loaded individually and automatically by addressing the digital inputs IN3 and IN2 on the Controller-Module via a parent machine controller, as indicated on the table shown above.</p>

<i>Item</i>	<i>Description</i>
4	BACK Button Press to return to the previous screen.
5	Restore Recipes This button is visible only if USB Flash Drive is inserted into the Touch Panel. Press this button to restore recipe collection from USB Flash Drive into the Touch Panel.
6	Backup Recipes This button is visible only if USB Flash Drive is inserted into the Touch Panel. Press this button to save recipe collection from Touch Panel to the USB Flash Drive.
7	Erase Recipe 1. Using the up and down arrows, select the number of the recipe you wish to erase. 2. Press Erase Recipe to delete the recipe from the controller/ Touch Panel.

5.11.7 Time & Scheduler Screen

- To go to this screen, press the Time & Scheduler button on the Settings Screen.
- This screen allows you to set the current date and time, and program the scheduler.

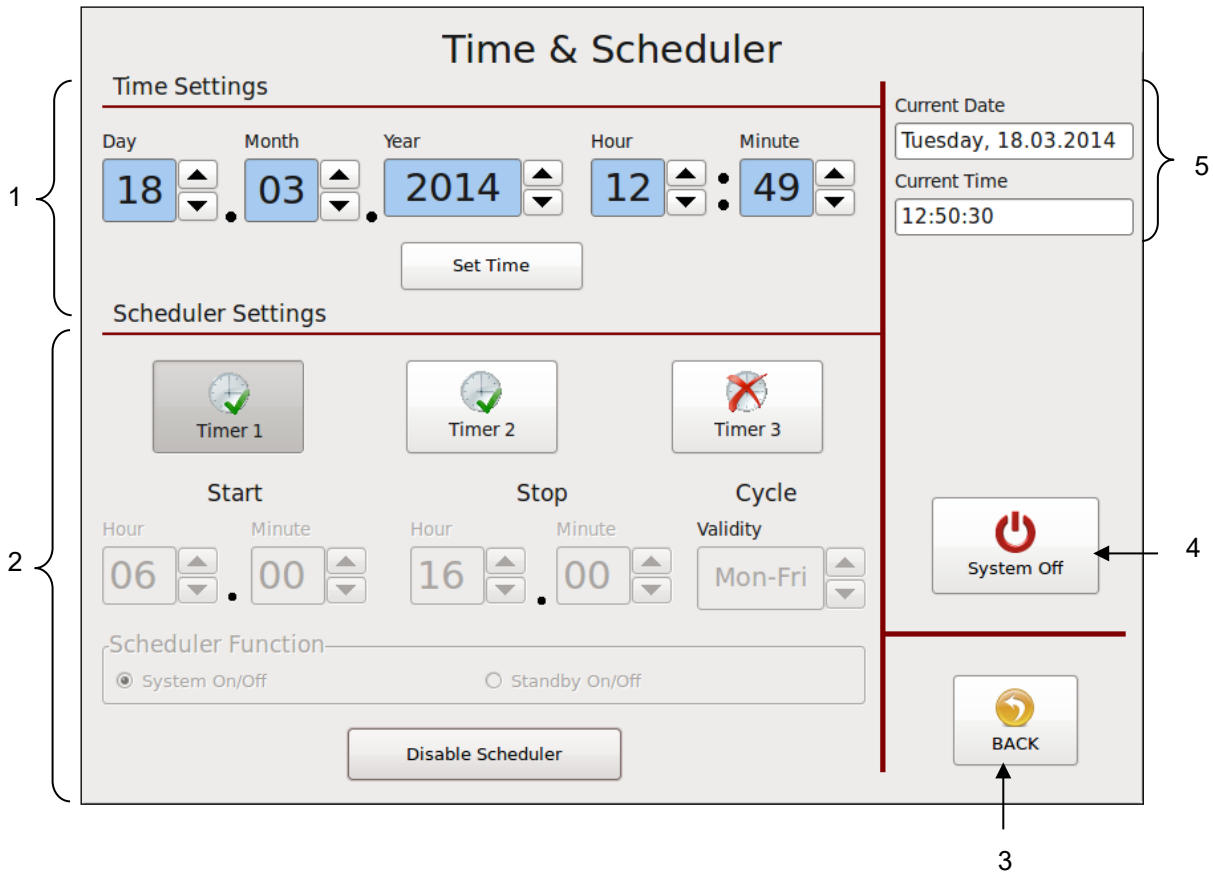

Item	Description
1	<p>Time & Date Settings The Time and Date are set with the buttons across the top of the screen. Using the up and down arrows, choose the current Day, Month, Year, Hour and Minute. To confirm these values, press Set Time. Afterwards, the current date and time will be displayed at right (item #5).</p>
2	<p>Scheduler Settings The controller's scheduler will automatically turn On the unit at the programmed start time and turn it Off at the programmed stop time on the programmed days (cycle). Up to three scheduler timers may be programmed either for System On/Off or for Standby On/Off. Each scheduler timer is programmed with a start time, a stop time and a cycle. Three cycles are available: Monday thru Friday, Saturday & Sunday or Sunday thru Saturday (i.e., every day). For example: The display illustrated above shows Timer 1 programmed and activated. It is programmed for System On/Off with a Start time of 06:00, a Stop time of 16:00 and a Cycle of Mon-Fri.</p>

Item	Description
2	<p>Programming</p> <ul style="list-style-type: none"> • Select a timer for programming by pressing Timer 1, Timer 2 or Timer 3. • Select either System On/Off or Standby On/Off. • Using the up and down arrows, set the start time hour and minute. The scheduler will automatically turn On the unit at this time. • Using the up and down arrows, set the stop time hour and minute. The scheduler will automatically turn Off the unit at this time. • Using the up and down arrows, set the cycle. The scheduler will automatically turn the unit On and Off on these days. • By pressing the Enable Scheduler button, the programmed parameters will be confirmed and the selected timer is activated. <p>To change a timer program, first select the desired timer. Then press the Disable Scheduler button. Now the selected timer can be re-programmed with new parameters as described above.</p> <p>The „clock“  icon appears in the status line on main screen if a timer is activated and disappears if the timer is deactivated.</p>
3	<p>BACK Button Press to return to the previous screen.</p>
4	<p>Turn System Off Press System Off to turn the system Off. Refer to "Control switch On/Off and Standby".</p>
5	<p>Current Date & Time Display of the current date and time as programmed into the controller.</p>

Example:

The display on the right shows Timer 2 programmed and activated for Standby On/Off with a Start time of 12:00, a Stop time of 13:00 and a Cycle of Mon-Fri.

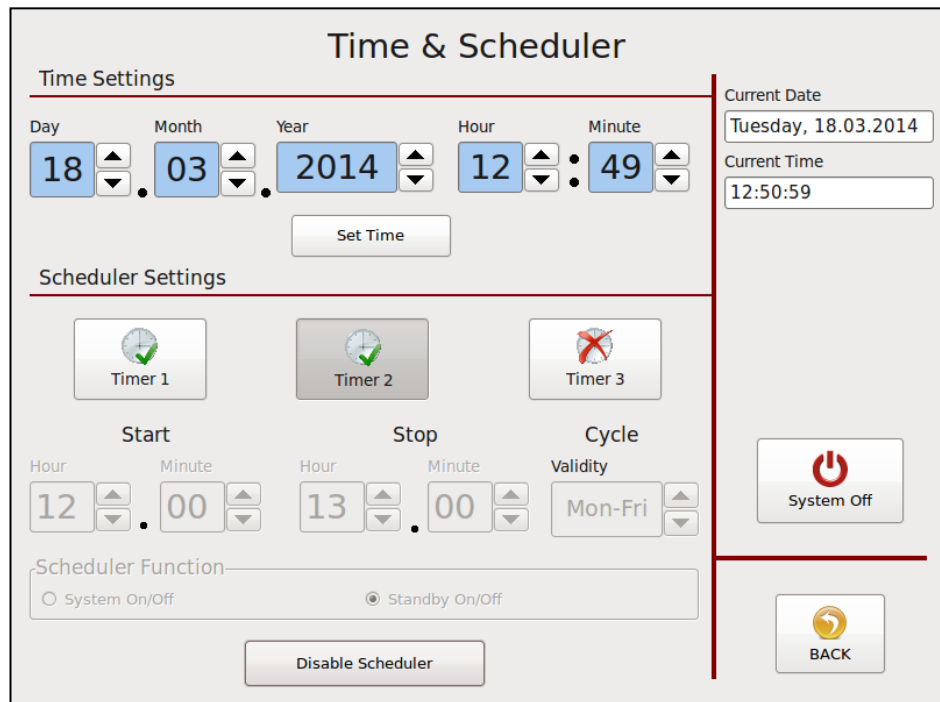

Example:
The display on the right shows that Timer 3 is not programmed and not activated:

Time & Scheduler

Time Settings

Day: 18, Month: 03, Year: 2014, Hour: 12, Minute: 49

Set Time

Scheduler Settings

Timer 1 (Active), Timer 2 (Active), Timer 3 (Inactive)

Start: Hour 07, Minute 00; Stop: Hour 16, Minute 00; Cycle: Mon-Fri

Scheduler Function

System On/Off Standby On/Off

Enable Scheduler

Current Date: Tuesday, 18.03.2014

Current Time: 12:51:14

System Off

BACK

5.11.8 Log Book Screen

- To go to this screen, press the Log Book button on the Settings Screen.
- The Log Book provides a read-only history of the last 100 (maximum) controller faults and events.
- If several systems are controlled by the HMI, all events will be listed here.

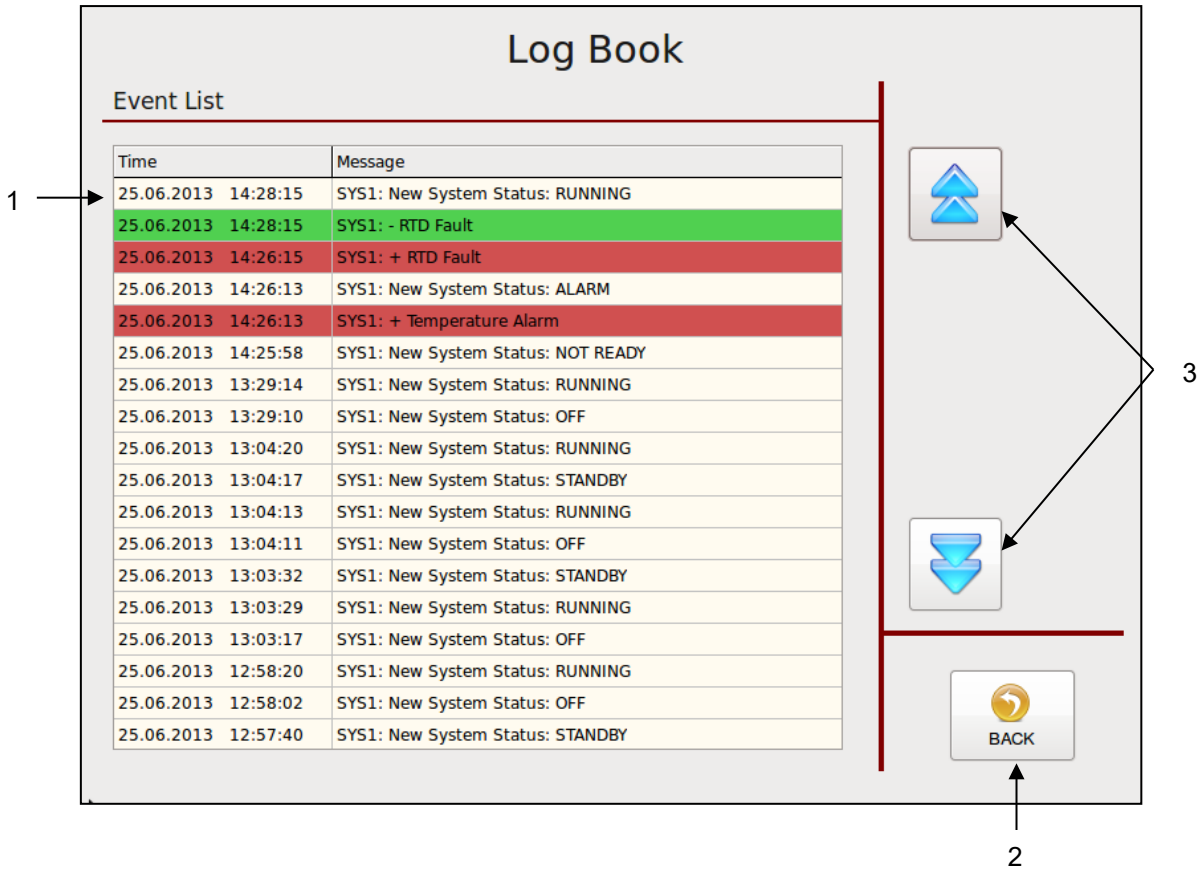

Item	Description
1	<p>The most recent event is recorded at the top of the Event List.</p> <ul style="list-style-type: none"> • Examples of events: System Status OFF, READY, RUNNING, STANDBY, NOT READY, Recipe loaded. • Examples of controller faults: RTD Fault, Temperature Alarm, Minimum Level, Drive Failure, Parameter CRC Error, Over-temperature, Communication error. See point "Faults, Alarms".
2	<p>BACK Button Press to return to the previous screen.</p>
3	<p>Scroll Buttons Press the arrow buttons to scroll up and down through the Event List.</p>

5.11.9 Security Screen

- To go to this screen, press the Security button on the Settings Screen.
- This screen allows you to set securities (with password) for access and for changing parameters.

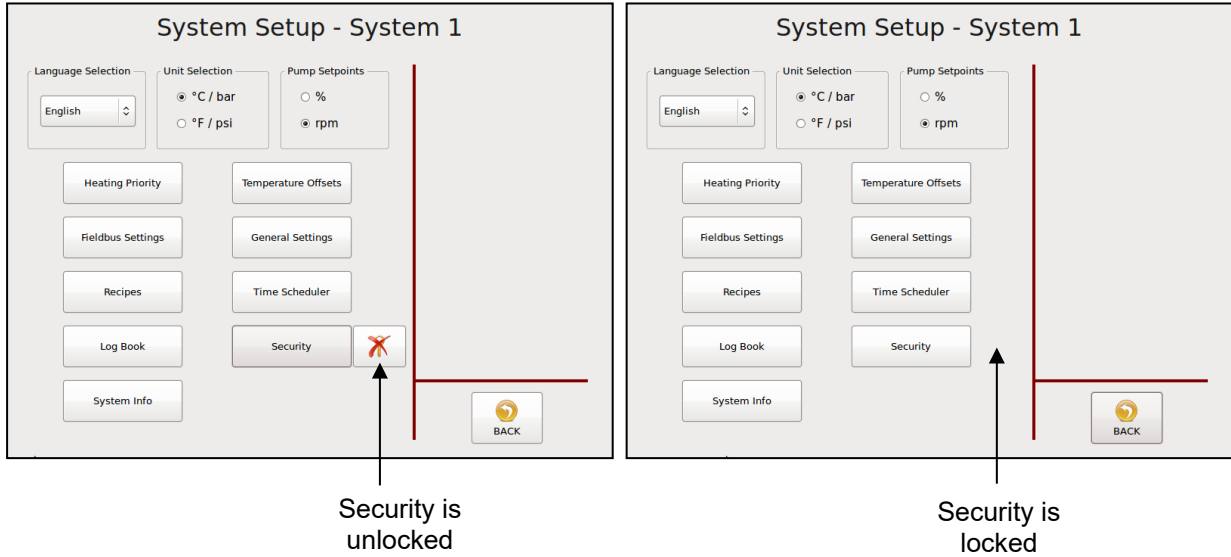

Item	Description
	<ul style="list-style-type: none"> • Security unlocked = access to the Security Settings is unlocked and settings may be changed by all users. The crossed-out Key icon, shown above, means Security is unlocked. After pressing the Key button, it will disappear, and the Security Settings will be locked. • Security locked = access to the Security Settings is locked and settings may only be changed by entering a password.

Continued on next page.

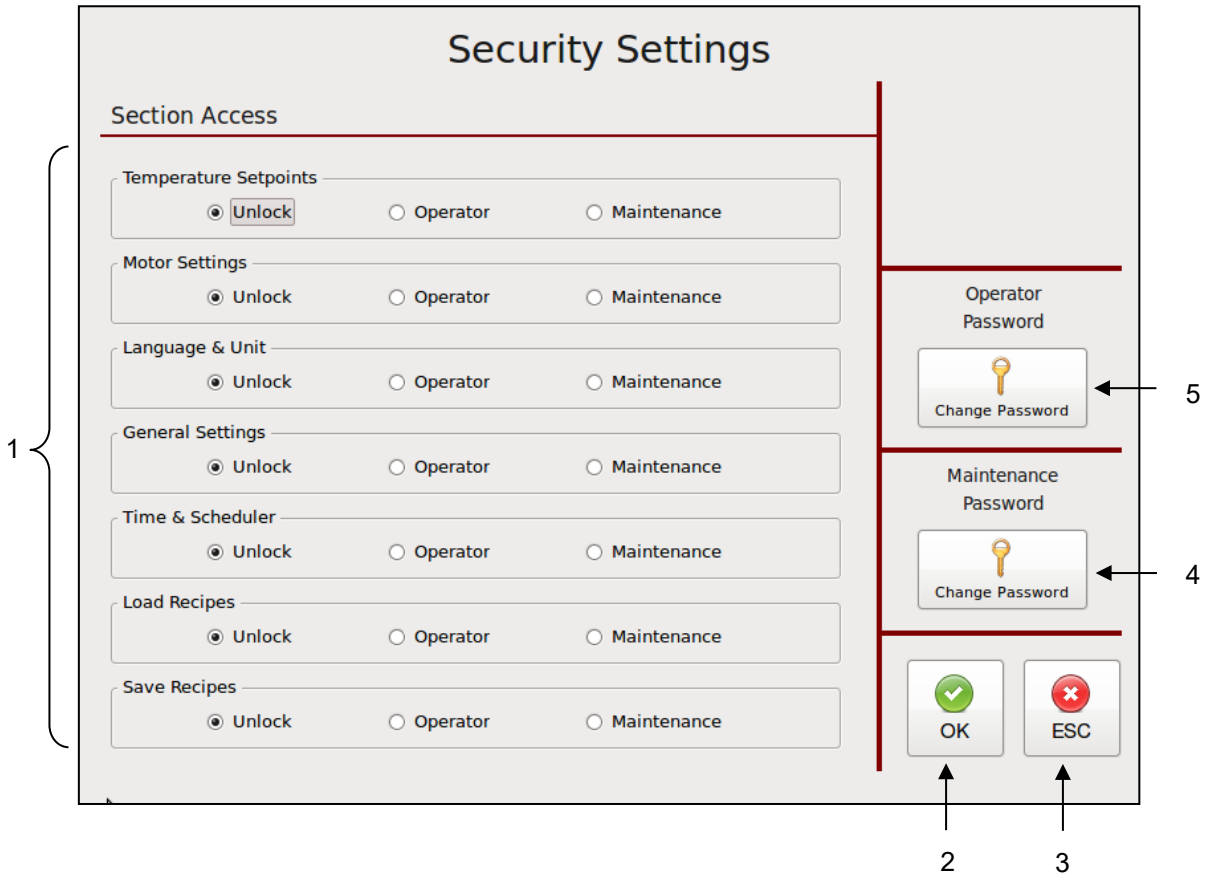

Item	Description
1	<p>Section Access Press the buttons to select access to each parameter as follows:</p> <ul style="list-style-type: none"> • Unlock = the parameter may be changed by all users. • Operator = the parameter may be changed by Operator personnel only, by using an Operator password. • Maintenance = the parameter may be changed by Maintenance personnel only, by using a Maintenance password.
2	Press the OK button to confirm your entered values and return to the previous screen.
3	Press the ESC button to discard any non-confirmed values and return to the previous screen.
4	<p>Change Maintenance Password Button Touch the Change Password button and a numeric entry keypad will appear. Enter desired numeric password (at least one digit). Press OK to confirm.</p>
5	<p>Change Operator Password Button Touch the Change Password button and a numeric entry keypad will appear. Enter desired numeric password (at least one digit). Press OK to confirm.</p>

5.11.10 System Info Screen

- To go to this screen, press the System Info button on the Settings Screen.
- This screen displays information about the V6 controller and its modules. The screen is read-only.

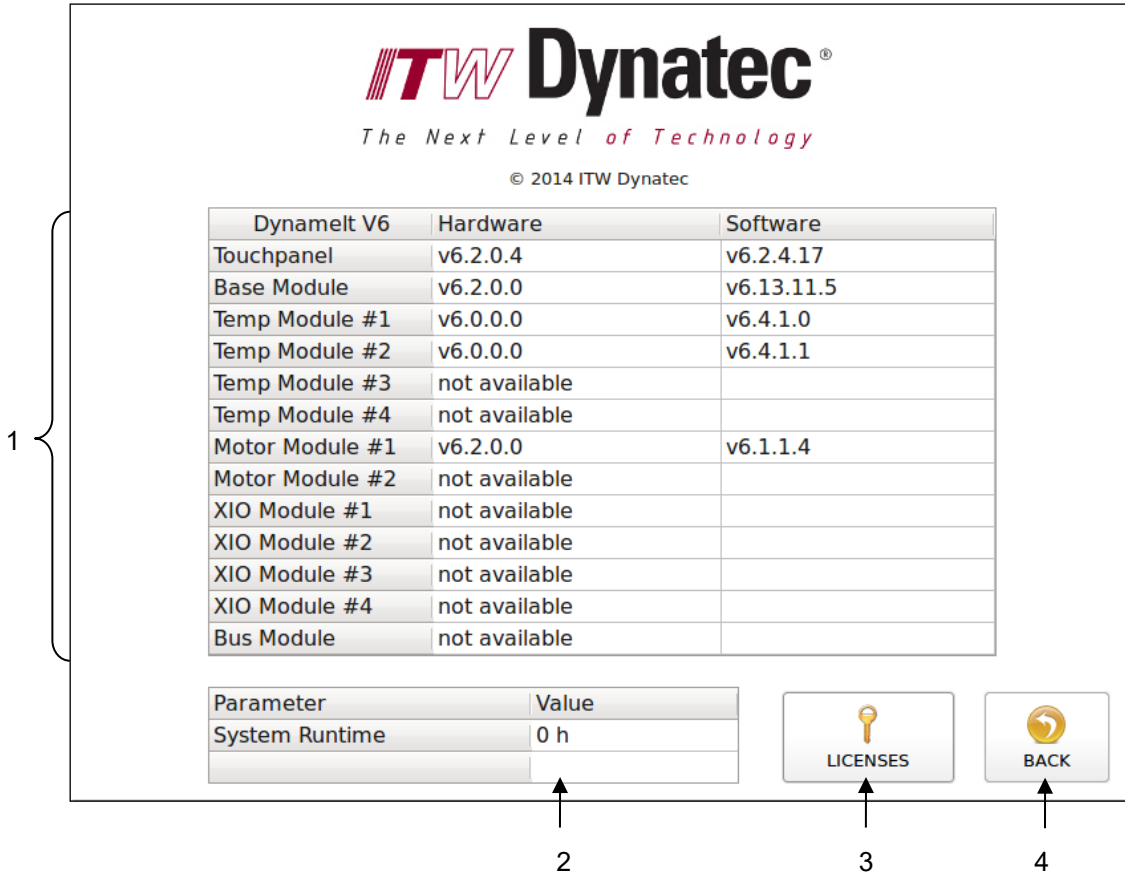

Item	Description
1	Information about the controller and its modules is displayed. The illustration above shows an example only.
2	The real System Runtime respectively pump runtime is displayed. The runtime of each day will be added.
3	Licenses Button Press to go to the License Management screen.
4	BACK Button Press to return to the previous screen.

5.11.10.1 License Management Screen

- To go to this screen, press the Licenses button on the System Info Screen.
- To purchase licenses with additional features, please contact ITW Dynatec Customer Service and provide your unit's serial number (provided on this screen). You will receive an USB Flash Drive with the license.

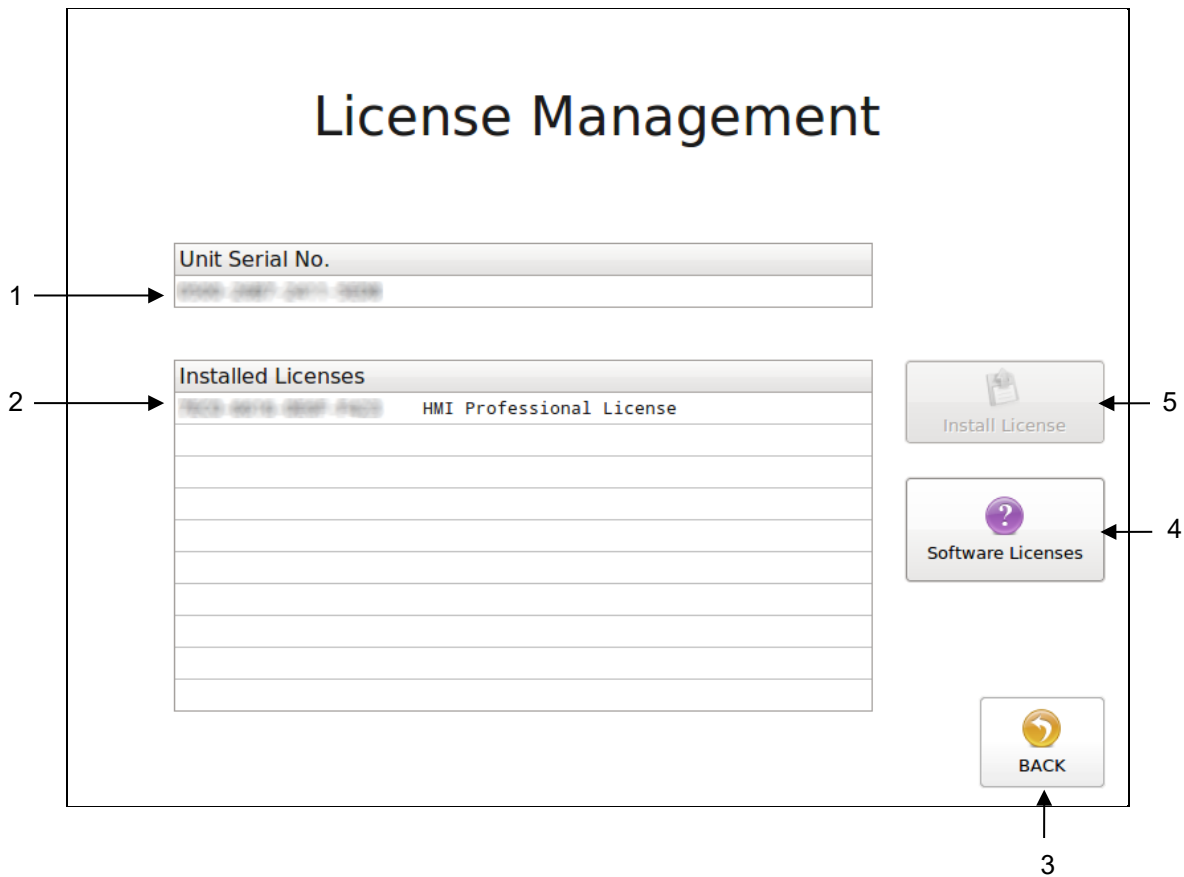

Item	Description
1	Unit Serial No. The serial number of your unit is displayed.
2	Installed Licenses The licenses installed on this unit are displayed (e. g. HMI Professional License). Note: The HMI Basic License with basic functions is installed on all units. The following licenses are available: <ul style="list-style-type: none"> • HMI Advanced License: activates additional features. • HMI Professional License: activates all available features. • HMI Feature License ARC: activates the Automatic Ramp Compensation (ARC) feature. • HMI Feature License Multi-System: activates the Multi-System feature.
3	BACK Button Press to return to the previous screen.
4	Software Licenses Button Press to see the used Open Source Licenses.
5	Install License Button To install a new license: After connecting the USB Flash Drive to your controller/ touch panel, press the Install License button on this screen to install the new license. After installation, the new license will be displayed on the Installed Licenses list. Afterwards, remove the flash drive from the controller.

5.11.10.2 Software Licenses

➤ To go to this screen, press the Software Licenses button on the License Management Screen.

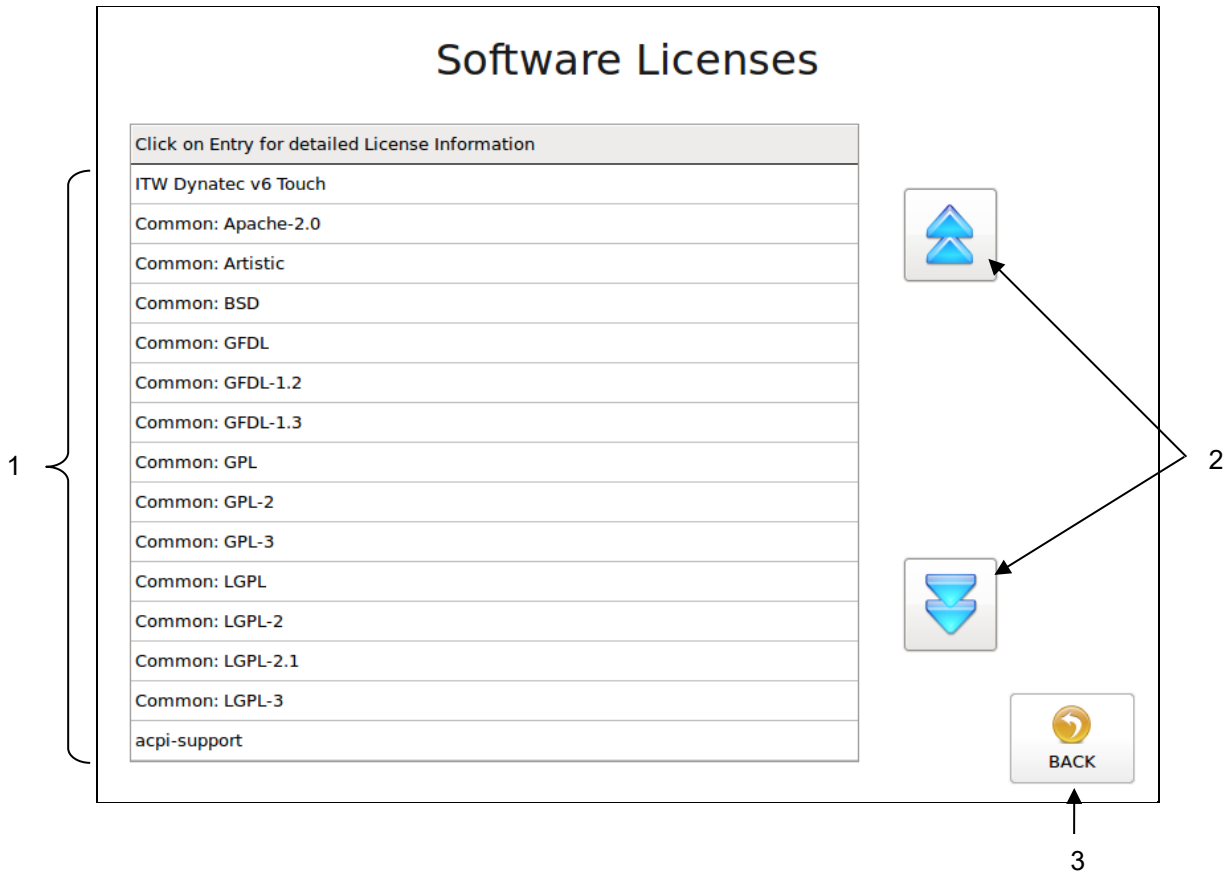

Item	Description
1	Display Software Licenses Click on Entry for detailed license information.
2	Scroll Buttons Press the arrow buttons to scroll up and down through licenses.
3	BACK Button Press to return to the previous screen.

5.12 Acknowledge Button

➤ The Acknowledge Button is on the Main Screen & Temperature Zones Set Screen.

System 2 - Mode: Local

READY 18.03.2014 11:48:25

1	125 °C	128 °C	125 °C	128 °C	125 °C	127 °C	23 %	1 10 bar	2 10 bar
2	126 °C	126 °C	125 °C	125 °C	126 °C	127 °C	25 %	1 13 bar	2 8 bar
3				124 °C	125 °C	126 °C			
4				129 °C	126 °C	126 °C			
5				128 °C	130 °C	127 °C			
6				128 °C	129 °C	126 °C			
7				127 °C	130 °C	126 °C			
8				128 °C	128 °C	126 °C			

ITW Dynatec®
 The Next Level of Technology

Empty

Set/Act Pumps Acknowledge Control Systems Settings



1: no faults or alarms indicated

Fault/ alarm
 Description in
 Status Line



System 2 - Mode: Local

ALARM RTD Fault 18.03.2014 12:58:33

1	126 °C	129 °C	126 °C	126 °C	126 °C	127 °C	0 %	1 10 bar	2 10 bar
2	126 °C	127 °C	125 °C	126 °C	126 °C	127 °C	0 %	1 13 bar	2 8 bar
3				124 °C	125 °C	126 °C			
4				129 °C	126 °C	126 °C			
5				128 °C	130 °C	127 °C			
6				128 °C	129 °C	126 °C			
7				FAIL	127 °C	130 °C			
8				128 °C	128 °C	129 °C			

ITW Dynatec®
 The Next Level of Technology

Empty

Set/Act Pumps Acknowledge Control Systems Settings



1: Fault indicated

Item	Description
1	<p>Acknowledge Button If a fault/ alarm is indicated, the affected temperature zone and the Acknowledge button will be highlighted red.</p> <p>When this occurs, follow these steps:</p> <ul style="list-style-type: none"> • Correct and clear the faults/ alarms. • Press the Acknowledge button in order to switch On the main contactor.

5.13 Faults/ Alarms

Among the Faults and Alarms that may be displayed are:

- **RTD Fault** = a hopper, hose or head sensor has an open circuit.
- **Temperature Alarm** = a temperature zone has exceeded its selected over-temperature setpoint, (which is the setpoint plus the Temperature Alarm Window and Temperature Alarm Hysteresis) or when it is below its selected under-temperature setpoint (which is the setpoint minus the Temperature Alarm Window and the Temperature Alarm Hysteresis).
- **Drive Failure** = a motor drive (frequency converter) has a fault.
- **Minimum Level** = adhesive level has dropped below the level sensor and the hopper is empty.
- **Feedback Failure Motor #** = (optional) speed monitor pump addressed.
- **Overtemperature** = hardware over-temperature indication.
- **Communication Error** = Communication error between the touch panel and controller.
- **Parameter CRC Error** = parameter memory is lost. Call ITW Dynatec Technical Service.
- **Other Faults or Alarms** = Call ITW Dynatec Technical Service.

When an alarm condition occurs, the current display will be interrupted only if a sensor (or motor drive) failure occurs. If more than one alarm condition occurs simultaneously, all alarm conditions will be displayed sequentially.

5.14 Operator Response to Error Indication Alarms





If an alarm occurs during operation, the controller will switch off the internal power to the heaters and an appropriate alarm indication will appear in the status line of the display.

Pressing the Acknowledge button resets the error. If several zones display alarms, each must be acknowledged. The operator must either switch OFF the indicated temperature zone(s) or troubleshoot to correct the problem.

Chapter 6

Maintenance and Repair Notes

6.1 Security advices for maintenance and repair

	<p>Heed all security advices given in Chapter 2.</p>
	<p>Use only original parts from ITW Dynatec, otherwise ITW Dynatec's warranty is void!</p>
	<p>Maintenance and repair work is only permitted for skilled personnel!</p>
	<p>Always wear safety shoes, heat-resistant protective gloves, safety goggles and protective clothing that cover all vulnerable parts of the body while working on the heated unit! Risk of injury or heavy burns!</p>
	<p>High Voltage! Risk of injury and mortal danger!</p> <ul style="list-style-type: none">• All electrical connections must be made by qualified electrical personnel.• Care must be taken to assure proper grounding prior to any disassembly.• Lockout and tag the electrical sources as required.• Make sure there is no electrical power on the leads you will be connecting.• When covers are removed, high voltage sources create an electrocution hazard.• Wear appropriate safety equipment when working with high voltage sources.
	<p>Parts and surfaces of the unit get very hot. High temperatures! Risk of heavy burns!</p>
	<p>High adhesive temperature and adhesive pressure! Risk of injury or heavy burns! Always assume that the system is under pressure, proceed with caution.</p>
	<p>Keep a cool-pack, or bucket of clean water near the work area.</p>
	<p>Place a heat-resistant catchment container/underlay under the components. Hot adhesive may come out.</p>
	<p>CAUTION: At working temperature, molten adhesive could cause heavy burns. Let spilled out adhesive cool down first, before removing it!</p>
	<p>CAUTION: Use only lint-free cleaning cloth and suitable cleaner for cleaning! Do not damage surfaces! Do not scratch above them with sharp-edged tools, otherwise the components will get leaky and inoperable!</p>
	<p>All maintenance and repair work has to be done at working temperature, except as noted otherwise. Else there is a risk of damaging the unit components!</p>
	<p>Before any service work disconnect the external power supply and switch the unit voltage-free:</p> <ol style="list-style-type: none">1. Switch off the main switch and the controller.2. Disconnect the power supply respectively remove the plug / cable.3. Guard the unit against unauthorized restarting!

Before any service work the adhesive pressure must be relieved throughout the system. Switch the unit pressureless:

1. Disconnect the pressure air supply.
2. Turn the pressure regulator to zero bar, if necessary. Wait approximately 1 minute until the pressure is relieved.
3. Open the applicators purge valve or open the modules by activating the solenoids to relieve any adhesive pressure.

6.1.1 Equipment Preparation for Maintenance & Repair

- Adhesive processing equipment must be worked on while hot enough to soften any material residue within the assembly. This depends on the type of adhesive used with the equipment. This may require the system to be up to operating temperature before disassembled, to prevent damage to fasteners and components.
- Once disassembled, the individual parts may be cleaned by immersion in approved solvent. Surface deposits may be removed by lightly scrapped with a brass device or scrapper. Care must be taken not to damage sealing surfaces with sharp objects or sand paper.
- Components such as O-rings, fasteners and relief valves should be discarded and replaced by certified ITW Dynatec replacement parts.

6.1.2 Re-Assembly Procedures and General Cautions

Unless noted, the re-assembly is simply the reverse sequence of the disassembly procedures. However, the following "cautions" should be followed (whenever they apply) for proper re-assembly:

**CAUTION**

In general, all O-RINGS AND SEALS must be replaced whenever hot-melt equipment is re-assembled. All new O-rings must be lubricated with O-ring lube (PN 001V078).

TAPERED PIPE THREADS are found on air pipe fittings used with the pump air supply and on the outlet filter manifold. Apply thread sealant (PN N02892) whenever tapered pipe threaded parts are re-assembled.

SOME FITTINGS used for adhesive on hot melt equipment have straight threads and O-ring seals. Use of thread sealant is not necessary with these parts, but the O-ring seals should be clean and lubricated. Tighten straight-threaded parts and fittings until their shoulders are firmly seated. Excessive torque may damage straight-threaded parts and the use of power wrenches is not recommended.

HOT-MELT RESIDUE must be cleaned from parts before they are re-assembled, particularly from threaded parts. As a precaution against adhesive residue preventing proper re-assembly, threaded parts must always be re-tightened at operating temperature.

6.1.3 Cleaning Recommendation

- Filters are disposable and need to be replaced regularly. DO NOT boil in mineral oil, solvents or water; the sealant used in filter assembly may become brittle and very likely disintegrate when boiled.
- When cleaning other components in mineral oil, remove all non-metallic items (O-rings, seals, filter cartridge, etc.) away from chemicals before components are subjected to hot mineral oil cleaning.
- If there is not a specific rebuild kit available or directions on how to clean a part, please treat it as a replacement item and do not attempt to clean/rebuild.

6.2 Maintenance plan



CAUTION

Heed all security advices given in Chapter 6.1.

Use only original parts from ITW Dynatec, otherwise ITW Dynatec's warranty is void!

Please use only the indicated lubricants and keep the prescribed maintenance intervals. Consider in addition the enclosed regulations of manufactures.

Punctual and conscientious maintenance of the unit secures not only a trouble-free function but prevents also for expensive repair costs.

Remove all materials and tools used during the repair or maintenance from the workspace of the unit.

Place a heat-resistant catchment container/underlay under the components. Hot adhesive may come out.

Use only lint-free cleaning cloth and suitable cleaner for cleaning! Do not damage surfaces! Do not scratch above them with sharp-edged tools, otherwise the components will get leaky and inoperable!

Summary of Preventive Maintenance Schedule & Maintenance plan:

Operating time/ frequency	Inspection point / maintenance notes
Continuous	<ul style="list-style-type: none"> Remove dropped out adhesive and scrap adhesive and search for the cause of that, eliminate the cause. Listen for abnormal sounds of the unit, e. g. from the motors, pumps, etc.
Once a day	<ul style="list-style-type: none"> Clean the Melter and components from dirt.
Once a week	<ul style="list-style-type: none"> Check pump and their seals for wearing and leaks and replace if necessary. Check for leaking adhesive under the base plate, caused by a worn pump seal. Check output filter for clogging and replace if necessary. Check pressure relief valves for function and replace if necessary. Check air supply connections for leaks and tighten if loose or replace if necessary. Check the solenoid valves for proper function and replace it if necessary.
Every 3 months	<ul style="list-style-type: none"> Inspect the filter and shutoff assembly. Clean or replace as required. Check pump mounting screws for tightness and tighten if necessary. Check all hose fittings for tightness and tighten if necessary. Due to temperature differences a loosening of threads (threaded connections) is possible. Check all parts with threads, all screw fittings and fasteners for tightness and tighten them if necessary.
Once a year	<ul style="list-style-type: none"> Clean the Melter. Complete check-up for wearing.
Every two years	<ul style="list-style-type: none"> Complete maintenance.

6.3 General Cleaning

The DYNAMELT M series Melter enclosure is finished with an extremely durable polyurethane paint. The enclosure may be cleaned with a variety of industrial cleaners following manufacturers' directions. To prevent discoloration or deterioration of the Melter's finish, avoid prolonged contact with strong solvents.

The molded plastic handles may be cleaned with mineral spirits.

6.4 Preventive Maintenance

6.4.1 Preventive Maintenance Schedule

The Dynamelt M requires periodic maintenance to function reliably.

The System Runtime indication of the controller (under System Info Screen) can aid in determining a maintenance schedule. Refer also to 6.2 Maintenance Plan.



The hopper is fitted with a coarse screen to prevent large debris from entering the system. Normally this screen does not require cleaning.

The Melter parts that require regular, periodic maintenance are as follows:

6.4.2 Outlet Filter, Checking and Replacement

The outlet filter should be replaced monthly during the first few months of operation. After you gain experience with your system, you can determine how often you need to replace it. The outlet filter is located on the outlet filter manifold on the hose connection panel of the Melter. See illustration of the outlet filter on next page.

Use the following procedure to replace the output filter:

	<p>WARNING! HIGH VOLTAGE! HIGH PRESSURE!</p>
	<ul style="list-style-type: none"> • Heed all security advices given in Chapter 6.1. • All electrical connections should be made by qualified electrical personnel. • Care must be taken to assure proper grounding prior to any dis-assembly. • Lockout and tag the electrical sources as required. • When covers are removed, high voltage sources create an electrocution hazard. • Wear appropriate safety equipment when working with high voltage sources. <p>Always wear safety shoes, heat-resistant protective gloves, safety goggles and protective clothing that cover all vulnerable parts of the body while working on the heated unit! Risk of injury or severe burns!</p> <p>Components and adhesive are hot. Take every precaution to prevent the material and hot surfaces from contacting the skin.</p>

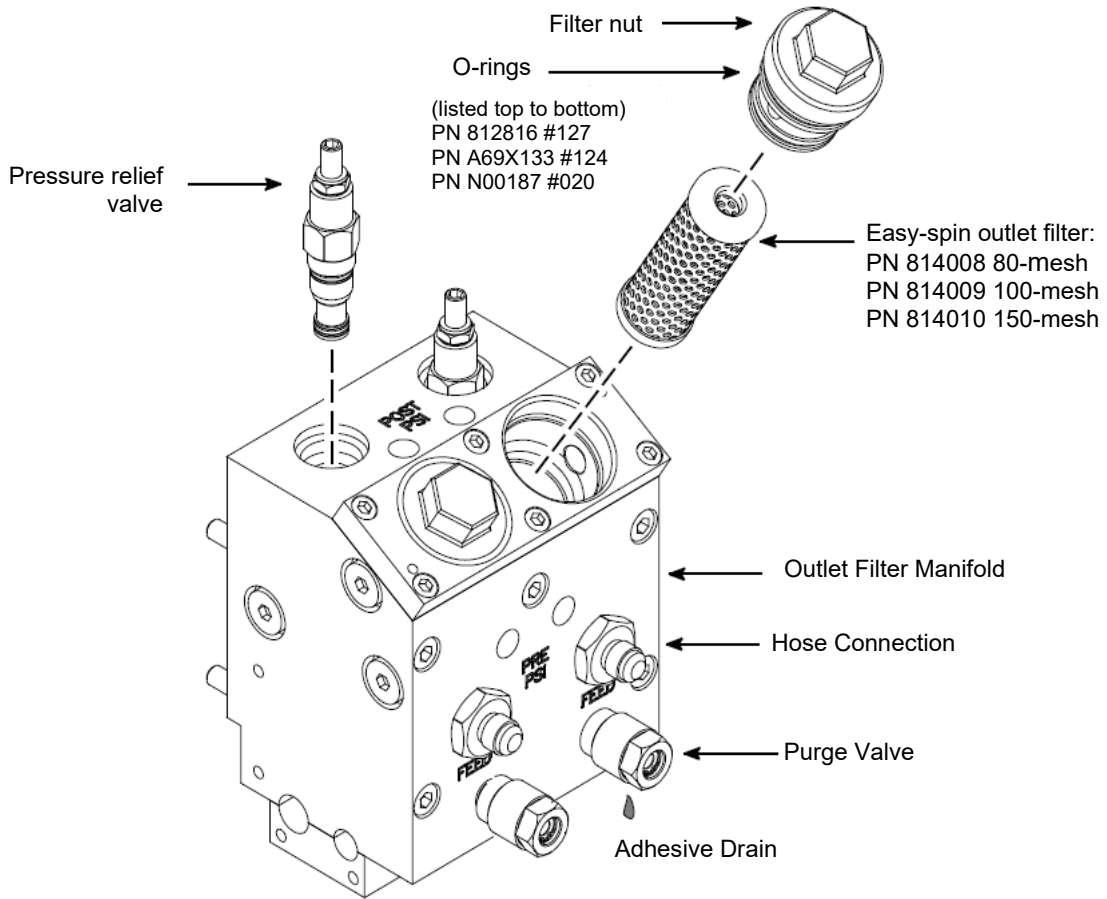

Easy-Spin Filter Manifold (located at the Hose Connection Panel)



NOTE:
The **filter cap** has right-hand thread and the **filter cartridge** has left-hand thread.

To replace the Output Filter:

1. The system should be at operating temperature.
2. Turn the pump/ motor OFF.
3. Switch the unit voltage-free and pressureless.
4. Guard the unit against unauthorized restarting.
5. Place a heat-resistant catchment container/underlay under the purge valve drip tray. Hot adhesive may come out!
6. Open the applicators/modules by activating the solenoid to relieve adhesive pressure.
7. Using a 5mm Allen wrench, slowly loosen the two purge valves (do not attempt to remove them) located on the fitting side of the filter manifold. Allow adhesive and pressure to escape out of the manifold. Adhesive will drain into the container.



- **During the purging procedure, hot adhesive can come out of the manifold under high pressure.**
- **Avoid splashing hot adhesive.**
- **Stand clear of the Melter until all pressure is relieved.**

- After pressure has drained from the filter manifold assembly, remove the filter from the filter manifold.



The filter will be covered with hot adhesive and must be handled with proper tools.

- Inspect the filter nut and O-rings for defects or degradation and replace if necessary. When replacing O-rings, lubricate the new O-ring with O-ring lubricant prior to installation.
- Install a new filter cartridge(s) onto the filter nut and reinstall the filter into the manifold.
Tighten to 10 lbs/ft (13 Nm).
The top of the nut should be flush with the top of the filter manifold when correctly installed.
- Close the pressure bleed (purge) valve, return the equipment to service and check for leaks.
- If leaking, it may be necessary to replace the filter nut O-rings.

Replacing the Optional High Flow Outlet Filter Basket:

- The system should be at operating temperature.
- Turn the pump/ motor OFF.
- Switch the unit voltage-free and pressureless.
- Guard the unit against unauthorized restarting.
- Place a heat-resistant catchment container/underlay under the manifold. Hot adhesive may come out!
- Open the applicators/modules by activating the solenoid to relieve adhesive pressure.
- Remove the Manifold Access Cover. **Note:** it is not necessary to remove the Lower Manifold Cover.
- Slowly loosen the drain plugs located on the filter manifold. Allow adhesive and pressure to escape out of the manifold. Adhesive will drain into the container.

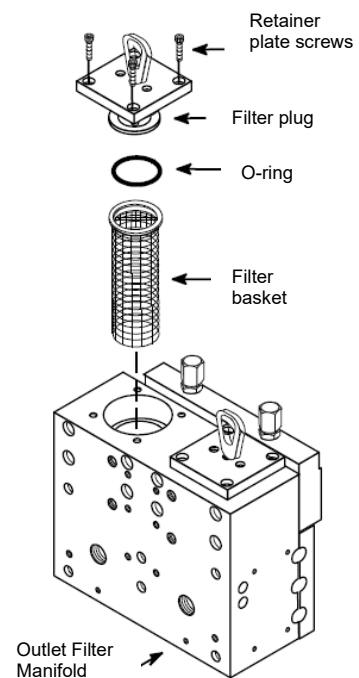

High Flow Filter Manifold



- During the purging procedure, hot adhesive can come out of the manifold under high pressure.
- Avoid splashing hot adhesive.
- Stand clear of the Melter until all pressure is relieved.

- Using insulated gloves and an Allen wrench, remove the retainer plate screws.

10. Lift out the retainer plate/ filter plug assembly.



The filter will be covered with hot adhesive and must be handled with proper tools.

11. Remove the clogged filter(s) and install a replacement filter.

Note: the filter(s) may be cleaned or replaced. If cleaning a filter, use only solvents recommended by your adhesive supplier.

12. Inspect the o-ring. Replace if flat or damaged.
13. Apply a coat of silicone lubricant onto the filter plug before re-inserting it into the manifold.
14. Apply a coat of anti-seize compound onto all screws before re-inserting.
15. Restore application system to normal operation.

After finishing the maintenance or repair works:

- Remove all materials and tools used during the repair or maintenance from the workspace of the unit.
- Connect the voltage supply and the compressed air supply. Heat the unit up. Wait until all temperatures are within the tolerances and the adhesive in the hopper is molten completely.
- Continue production.

6.4.3 Hose Fittings

All hose fittings should be checked for tightness after every three months of operation.

6.4.4 Fasteners

Check that all fasteners are tight after the first ten hours of operation. Thereafter, re-check all fasteners after every three months of operation.

6.4.5 Filter and Shutoff Assembly, Cleaning or Replacement

Heed all security advices given in Chapter 6.1.

Maintenance and repair work is only permitted for skilled personnel!

Always wear safety shoes, heat-resistant protective gloves, safety goggles and protective clothing that cover all vulnerable parts of the body while working on the heated unit! Risk of injury or severe burns!

The filter cartridge will be covered with hot adhesive and must be handled with proper tools.
Components and adhesive are hot. Take every precaution to prevent the material and hot surfaces from contacting the skin.



 **NOTE on Function:**

- This assembly is installed in the hopper (tank) in the adhesive channel to the pump. It functions as a pre-filter (primary filter), it filters debris and it prevents them from entering into the adhesive system. During production it must always be turned **open "1" (vertical position)**.
- Turn this assembly to the **closed position "0" (horizontal position)**, for example during pump replacement, to prevent that the adhesive flows out of the tank (shutting-off the adhesive flow).

NOTE: See the illustrations in Chapter 10.3 (Grid Assembly) for location of the Filter and Shutoff Assemblies.

M210 models have two Filter and Shutoff Assemblies.

1. Pump all adhesive out of the hopper.
2. Turn the pump/ motor OFF.
3. Lower the temperature of the application system to the adhesive's softening point.
4. Switch the unit voltage-free and pressureless.
5. Guard the unit against unauthorized restarting.
6. Open the two access doors located at the sides of the Melter.
ATTENTION: Do not pull out the ground wires attached.
NOTE: The filter and shutoff assemblies are located on either side of the hopper.
Repeat this procedure for each assembly.
7. Place a heat-resistant catchment container/underlay under the applicator and open the applicator/modules by activating the solenoid to relieve adhesive pressure.
8. Place a heat-resistant catchment container/underlay under the purge valve of the filter manifold (see illustration in section ("Output Filter, Checking and Replacement"). Hot adhesive may come out!

Wearing insulated gloves, arm guards and a face shield, use a 5mm Allen wrench to open the purge screw within the purge valve. A small amount of adhesive will pop out of the drain valve, relieving stored pressure in the manifold. Allow the adhesive to drain into the container.

 • **During the purging procedure, hot adhesive can come out of the manifold under high pressure.**

- **Avoid splashing hot adhesive.**
- **Stand clear of the Melter until all pressure is relieved.**



WARNING HOT SURFACE

The Melter will still be hot during this procedure.

Use insulated gloves and protective clothing when removing the filter and shutoff assembly.

9. After all pressure has been drained from the manifold, use a wrench to unscrew the filter retaining nut and pull the filter and shutoff assembly out of the hopper.
10. Immerse the clogged filter in flushing fluid (PN L15653) to loosen contaminants. Remove assembly from fluid and use a hot air gun (if necessary) and rags to clean all contaminants from it.
NOTE: If the filter cannot be cleaned, replace the entire filter and shutoff assembly.
11. Install a new O-ring PN N00210 on the filter and shutoff assembly. Lubricate the new O-ring with lube (PN 001V078). Apply a coat of anti-seize compound onto the threads of the filter retaining nut and re-install the filter and shutoff assembly into the hopper.
12. When re-installing the filter assembly, turn the filter's cut out hole toward the pump. Align the knob of the filter and shutoff assembly in its "open" "I" position (vertical position).
13. Close the access doors. Restore the Melter to normal operation.

After finishing the maintenance or repair works:

- Remove all materials and tools used during the repair or maintenance from the workspace of the unit.
- Connect the voltage supply and the compressed air supply. Heat the unit up. Wait until all temperatures are within the tolerances and the adhesive in the hopper is molten completely.
- Continue production.

6.4.6 Pump Shaft Leak

There is a cutout in the base plate, directly below the pump shaft(s), which will allow adhesive from a leaking pump to exit the Melter. Inspect the area under the base plate cutout every month for adhesive. A leaking pump shaft indicates a worn pump seal. See instructions in Chapter 8 for replacement of this seal.

6.4.7 Flushing the System

Contaminated adhesive, accumulation of residue in the system and hopper, or changing the adhesive formulation may require the system to be flushed. To flush the system, have at least 6 liters (1.5 gallons) of flushing fluid on hand (PN L15653) per hopper. Repeat this procedure for each hopper of a dual hopper Melter.

	<p>WARNING</p> <p>Heed all security advices given in Chapter 6.1.</p>
	<p>Maintenance and repair work is only permitted for skilled personnel!</p>
	<p>Always wear safety shoes, heat-resistant protective gloves, safety goggles and protective clothing that cover all vulnerable parts of the body while working on the heated unit! Risk of injury or severe burns!</p>
	<p>Components and adhesive are hot. Take every precaution to prevent the material and hot surfaces from contacting the skin.</p>

1. Pump out as much of the molten adhesive from the hopper as possible.
2. Reduce the motor/pump speed to zero.

Note: the hose used in the following process is merely for the convenience of depositing flushing fluid. This procedure does not have to be repeated for each hose in the system.

3. Disconnect one of the supply hose's adhesive feed from its applicator head. Do not disconnect the electrical power to the head (since that would disable the pump). Put the hose in a secured position within a heat-resistant container, which will catch the used flushing fluid.
4. Add flushing fluid to the hopper and allow approximately fifteen minutes for it to reach hopper temperature. Carefully stir the flushing fluid to mix with any adhesive remaining in the hopper.
5. Slowly increase the motor/pump speed. Pump as much of the flushing fluid through the hopper, pump and adhesive supply hose into the flushing container.

	<p>WARNING HOT ADHESIVE</p> <p>Avoid splashing the flushing fluid from the end of the hose.</p>
---	--

6. Reduce the motor/pump speed to zero.
7. Remove the outlet filter and replace the basket following the procedures outlined in the "Outlet Filter" section of this chapter.
8. Add new adhesive to the hopper and allow it to reach application temperature.

9. Slowly increase the motor/pump speed.
10. Actuate each of the heads until all the flushing fluid is removed and a steady stream of new adhesive flows.
11. Re-adjust the motor/pump speed for the desired flow.
12. Re-fill the hopper with adhesive. The system is now ready for production.

6.4.8 Panel Box Fan's Exhaust Filter

An air-circulating fan and exhaust grill are mounted in the side panels of the electrical panel box assembly (PBA). The exhaust grill (mounted in the upper side panel) contains a filter, which should be cleaned periodically.

Replacement and/ or Cleaning of Fan Filter

1. The exhaust grill assembly may be pulled out of the panel box from the outside of the panel box assembly. The exhaust grill is hinged at its top. Open the grill and remove the filter.
2. Wash filter in water up to 40°C (104°F) with a mild detergent added, if necessary. Or vacuum, beat or carefully blow the filter with compressed air.

To clean greasy substances:

- Wash filter in benzine, trichloroethylene or warm water with a grease solvent added.
- Do not wring or use a sharp jet of water or compressed air.

Chapter 7

Troubleshooting

7.1 General Troubleshooting Notes



NOTE: Please re-read all security advices given in Chapter 2 before performing any troubleshooting or repair procedures.

All troubleshooting or repair procedures must be performed by qualified, trained technicians.



DANGER HIGH VOLTAGE

The Dynamelt Melter uses electrical power that can be life threatening.



WARNING HOT SURFACE

The Melter uses hot-melt adhesives that can cause serious burns.

Severe burns can occur if unprotected skin comes in contact with molten adhesive or hot application system parts.

Some of the procedures in the following Troubleshooting Guide require working near hot adhesive.

Face shields (preferred) or safety glasses (for minimum protection), heat-resistant protective gloves and long-sleeved clothing must be worn whenever working with or around adhesive application systems.

Use proper tools for handling hot melt components.



CAUTION

Printed circuit boards (PCBs) are prone to damage from static electrical charges during handling. Read the section on "Handling Printed Circuit Boards" before handling or attempting service on Dynamelt's PCBs.

The DynaControl includes malfunction self-diagnostics, alerts and error indication alarms. The error indication alarms (the alarms displayed on the DynaControl readout) are triggered whenever there is a sensor failure and whenever there is an over-temperature condition. The operation of the error indication alarms is described in Chapter 5 of this manual.

7.1.1 Preliminary Checks: Verify the following before proceeding:

1. The Melter is switched on.
2. The Melter is supplied with power.
3. The Melter is supplied with pneumatic air (if applicable).
4. Pneumatic and electrical connections are correct.
5. Adhesive is in the hopper.
6. The temperature controller is in operation. The setpoints are correct for the Melter, Heated Hoses and Applicators. All components are heating properly.

7.1.2 Error Messages

The controller indicates an error by displaying the word FAULT or ALARM in either the System Status or the Pump Status fields of the HMI.

7.1.3 Hose/ Applicator Troubleshooting Tip

Hose or Applicator problems can be isolated by electrically connecting the Applicator and hose to an alternate socket on the Melter. If the malfunction goes with the Applicator and hose, the problem will usually be in the Applicator or hose that was moved. If the malfunction does not move with the Applicator and hose, the problem is probably in the Melter.

Before disconnecting a hose or Applicator, always turn its temperature zone OFF at the controller. This will avoid controller alarms and possible system shutdown.

7.1.4 High-Temperature Redundant Overtemperature Thermostat

The Melter includes a mechanical (redundant) overtemperature thermostat that acts as a safety backup. If the Melter's hopper temperature should exceed 232°C (450°F), the thermostat will cause the Melter's power relays to open and power to the hopper and all hoses and heads will be cut off. The mechanical thermostat must be manually re-set after the hopper temperature falls below 204°C (400°F).

The overtemperature thermostat is located on the front side of the hopper, behind the access cover. To reset: turn OFF the Melter's main power switch; loosen the captive screw to remove the access cover; push the center of the thermostat's insulator to re-set; restart the Melter.

7.1.5 DynaControl V6 Modules

The DynaControl V6 control package is built from encapsulated modules that snap onto the DIN rail within the Melter. The modules communicate via a proprietary serial communication. Each module has a status LED (ON/ERR). This LED shows the module's status, as follows:



- Blinking green = Everything o.k. Communication is working.
- Solid red = Communication fault.
- No Light = Module is defective or no voltage supply.

7.1.6 Handling Printed Circuit Boards (PCBs)

The Dynamelt Melter and DynaControl controller utilize several modules and printed circuit boards (PCBs). These boards are extremely sensitive to electrostatic charges. When working near or with these components, the following procedures must be followed to avoid damage to them.



DANGER HIGH VOLTAGE

Before unplugging connectors from the modules or I/O PCBs, ground yourself to the Melter by touching any available unpainted cool metal surface, mounting screws, etc. This will avoid electrical discharge to the assembly when you are removing and replacing connectors.



CAUTION

Modules and printed circuit boards (PCBs) should be handled using the following procedures:

1. Wear a wrist grounding strap. If a grounding strap is not available, frequently touch a bare metal part of the Melter (unpainted frame, mounting screw, etc.) to safely discharge any electrostatic buildup on your body.
2. Handle a PCB by its edges only. Don't grip a PCB across its surface.
3. When removed from the Melter, each PCB must be individually packaged inside a metalized, static drain envelope. Do not place the removed PCB on a table, counter, etc. until it has first been placed in or on a static drain envelope.
4. When handing a PCB to another person, touch the hand or wrist of that person to eliminate any electrostatic charge *before* you hand the PCB to him.
5. When unwrapping a PCB from its static drain envelope, place the envelope on a *grounded, nonmetallic* surface.
6. To cushion modules or PCBs for shipment, use only static-drain bubble pack. Do not use foam peanuts or bubble pack not known to be static draining.

The following pages detail the Melter's modules and PCBs.

7.2 V6-Base Module PN 115734

The V6 Base Module is the main control module of the DynaControl V6 controller. Most of the internal and external components are connected to the Base module. The Base module is always the first module on the DIN-rail.



ITW Dynatec recommends using dry contacts for connecting to DynaControl V6!

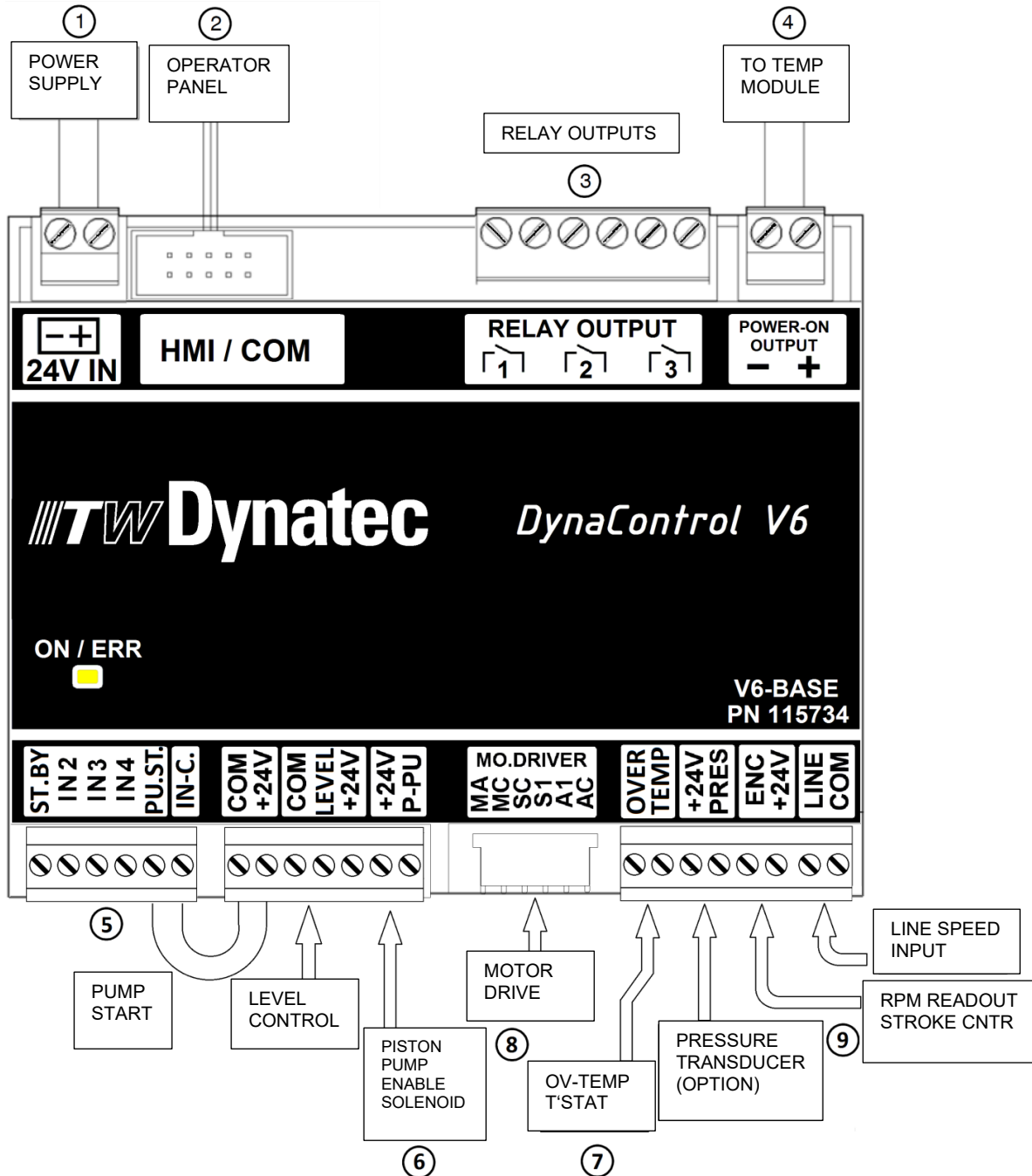

V6 Base Module, cont.

Description of Components

The following items are referenced to the illustration on previous page:

- **Item #1** The controller runs on standard 24VDC. The supply voltage, coming from the 24VDC power supply, is connected to this terminal. The input is polarity sensitive.
- **Item #2** The operator's panel connects to this header via a ribbon cable. There are several types of operator's panels available. They are interchangeable.
- **Item #3** This connector provides customer accessible relay contacts. There are three pairs of dry contacts which are designed for maximum 240 VAC/1A.

The default functions of the relays are:

Relay 1: Ready Signal

This contact closes once the system is in ready condition (ready condition = all active temperature zones are within their tolerances and there is no other alarm message pending). Normally open.

Relay 2: Alarm Signal

This contact opens whenever a critical situation arises. A critical situation could be a defective temperature sensor, an over or under temperature situation, a motor driver fault, etc. Normally closed.

Relay 3: Hopper Empty Signal

This contact closes when the adhesive level in the hopper drops below a certain level. It can be used to indicate this situation via an external light or an audible alarm. Normally open.

Note: Depending on the controller's settings, one or more of the relay outputs may be re-programmed for different purposes. In this case, refer to corresponding set-up instructions.

- **Item #4** This connector is used for a module-to-module connection. It provides the power-on signal to the power board through the TEMP board. In the case of a critical alarm, this 24 VDC signal will drop, cutting off the heater power on the power boards. This signal may also control the main contactor.
- **Item #5** This connector accepts external signals that can be used to control the Melter. The inputs require 24VDC signals. Although the internal 24VDC can be used to provide voltage for the inputs, it is recommended to use external 24VDC. For this purpose, the common of the signal inputs is available on terminal IN-C. and is isolated from the internal 24VDC.

All inputs are not polarity sensitive. That means the common (IN-C.) can either be positive or negative.

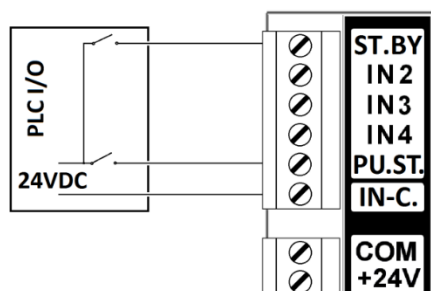

V6 Base Module, cont.

Alternatively, it is possible to use the external inputs via 'dry' contacts:

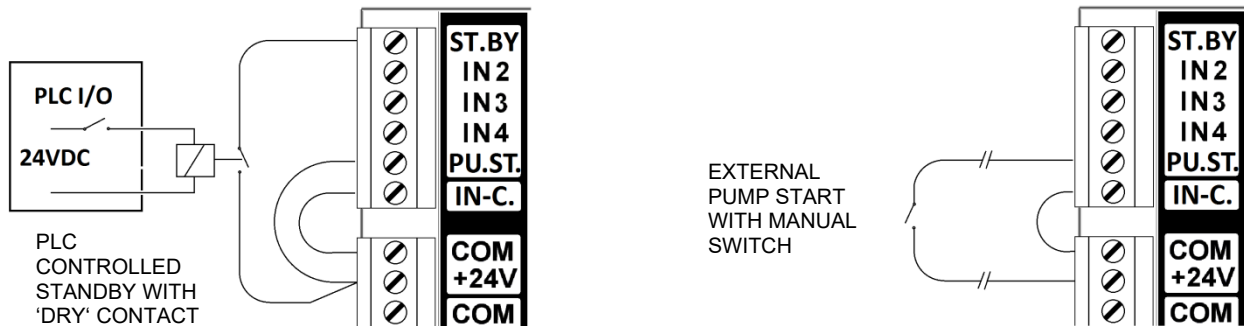
**WARNING:**

The Melter's internal 24VDC is grounded. It is not recommended to connect external 24VDC with the internal. If this cannot be avoided, it is important that the ground potential of the external and that of the Melter is equal. If this is not the case, damage to the V6 control modules is possible.

Inputs ST.BY, PU.ST. IN2 and IN3 are dedicated for default functions. Input 4 is for future use.

Input ST.BY: External Standby/ Setback

Activating this input sets the Melter in Standby Mode.

In standby mode, all temperature zones will lower their temperatures by a programmed amount. Opening that contact will return to normal mode.

Input IN2 & IN3: External Program/ Recipe Selection

By activating these inputs, it is possible to load one of four programs (recipes) into the controller.

The two inputs are coded in the following way:

- Activate input2 while input3 is not activated: **Load Program 1**
- Activate input3 while input2 is not activated: **Load Program 2**
- Activate input2 while input3 is activated: **Load Program 3**
- Activate input3 while input2 is activated: **Load Program 4**

Notes: the controller loads the new program when the corresponding input is activated. Deactivating an input does not affect the process.

It is possible to load a new program manually, independent from the input situation.

- **Item #6** This item is not applicable.
- **Item #7** This input is connected to the over-temperature thermostat on the hopper. In the unlikely event that that hopper temperature exceeds 450°F (232°C), the thermostat will open and cause the power to all the heaters to be cut off. A corresponding alarm message will appear on the controller's display. The thermostat must be manually re-set after the hopper temperature falls below 400°F (204°C).
- **Item #8** This connects to the motor driver.
MB / MC: Alarm contact indicating driver fault (N.C.).
SC / S1: Pump start signal.
A1 / AC: 0-10V pump speed signal.

• Item #9

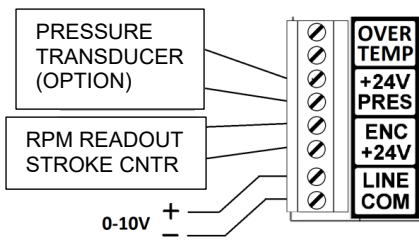

If the Melter is equipped with a digital pressure read-out, it connects to this terminal. The transducer type is two-wire 4-20mA.

In order to monitor the actual speed, an RPM reading device (gear pumps) or stroke counter (piston pumps) can be connected to this terminal.

In order for a gear pump to follow the line speed of a parent machine, a 0-10VDC voltage is required. This input voltage is connected to these terminals. The input is polarity sensitive. When an optional signal isolator is installed, the line speed input is located on the signal isolator.

Warning: The line speed input is grounded. If the line tracking voltage has a different ground potential, it is recommended to use a signal isolator. Otherwise, damage to the V6 modules is possible.

7.3 V6-Temperature Module PN 115735

The V6 TEMP module is mounted next to the V6 base Module on the Din-rail. It requires 24VDC supply voltage. It is responsible for the temperature control of all heated temperature zones. The RTD temperature sensors connect to this module and the TEMP module provides corresponding output signals to the power boards. Depending on the configuration of the Melter, the RTDs may be PT100 (DynaControl) or NI120 (NDSN). Configuration is determined by a jumper located within the module (see below, to left of module illustration).

Each of the maximum 15 zones has a status LED which shows its heating status in the following manner:

- if the zone is switched off, the LED is Off,
- if the zone is heating, the LED is On,
- if the zone is near or at the setpoint temperature, the LED blinks.

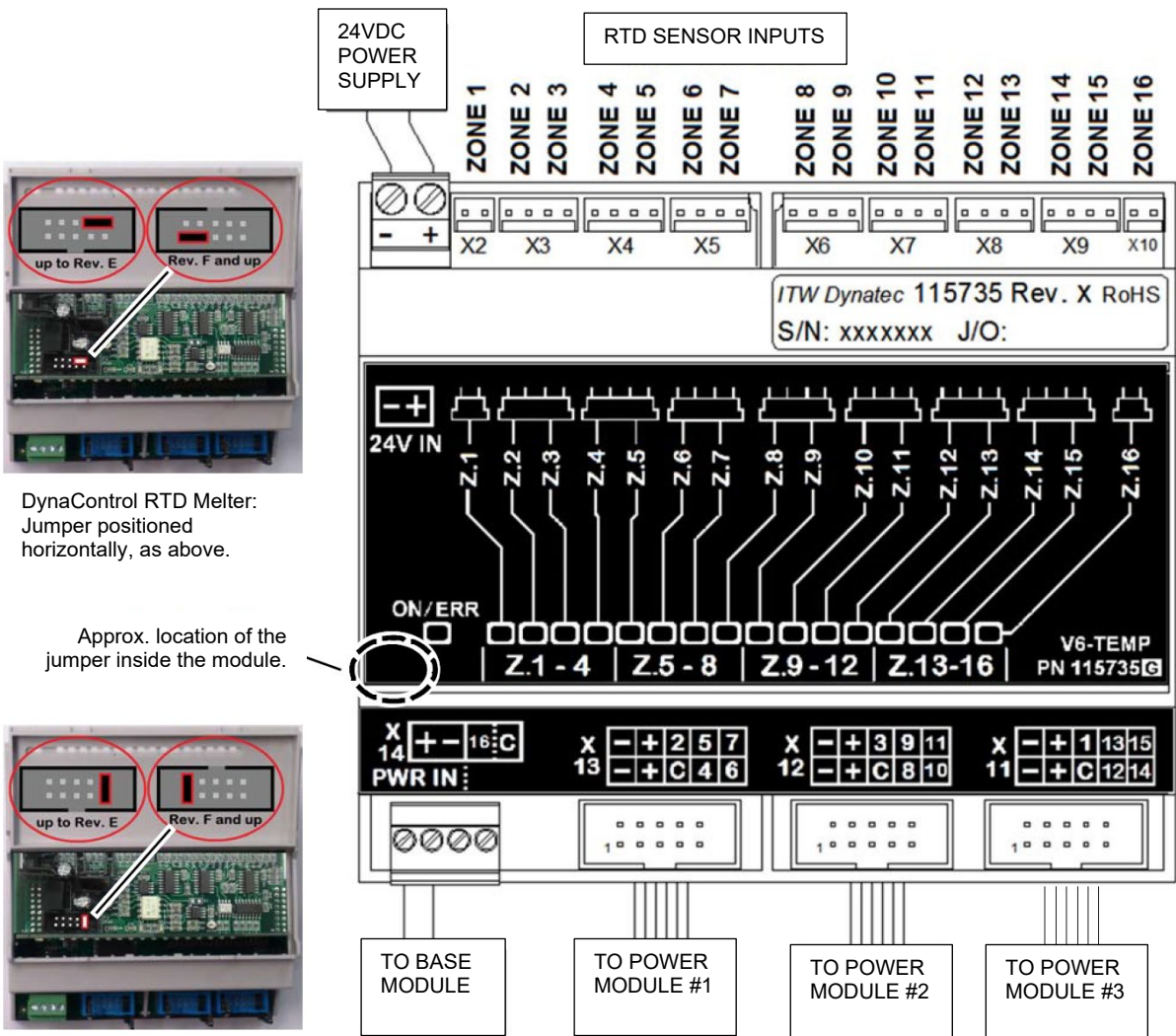

DynaControl RTD Melter:
Jumper positioned horizontally, as above.

Approx. location of the jumper inside the module.

NDSN RTD Melter: Jumper positioned vertically, as above.

Heater Control output.

7.3.1 Standard System Zone Tables

Dynamelt M210

Zone 1	Pre-Melt Grid 1
Zone 2	Hopper 1
Zone 3	Filter Block 1
Zone 4	Hose 1
Zone 5	Head 1
Zone 6	Hose 2
Zone 7	Head 2
Zone 8	Hose 3
Zone 9	Head 3
Zone 10	Hose 4
Zone 11	Head 4
Zone 12	Aux 1
Zone 13	Aux 2
Zone 14	Aux 3
Zone 15	Aux 4
Zone 16	Pre-Melt Grid 2
Zone 17	Pre-Melt Grid 3
Zone 18	Hopper 2
Zone 19	Filter Block 2
Zone 20	Hose 5
Zone 21	Head 5
Zone 22	Hose 6
Zone 23	Head 6
Zone 24	Hose 7
Zone 25	Head 7
Zone 26	Hose 8
Zone 27	Head 8
Zone 28	Aux 5
Zone 29	Aux 6
Zone 30	Aux 7
Zone 31	Aux 8
Zone 32	Pre-Melt Grid 4
Zone 33	Pre-Melt Grid 5
Zone 34	Hopper 3
Zone 35	Filter Block 3
Zone 36	Hose 9
Zone 37	Head 9
Zone 38	Hose 10
Zone 39	Head 10
Zone 40	Hose 11
Zone 41	Head 11
Zone 42	Hose 12
Zone 43	Head 12
Zone 44	Aux 9
Zone 45	Aux 10
Zone 46	Aux 11
Zone 47	Aux 12
Zone 48	Pre-Melt Grid 6

7.4 V6-Power Module PN 823306

Each V6 Power module consists of two identical PCBs which together provide controlled power to the heaters of eight zones. It receives its control signals from the V6 TEMP module. Depending on the configuration of the Melter, there may be several V6 Power modules in the system. Connections are made to both sides of the module.

The fuses are located underneath a protective cover. The cover should only be removed after the Melter is switched Off and disconnected from the main power supply. After checking or replacing fuses, the cover must be re-installed. All heater circuits are fused on both legs with a 10AF fuse. Always replace fuses with the same type of fuse.

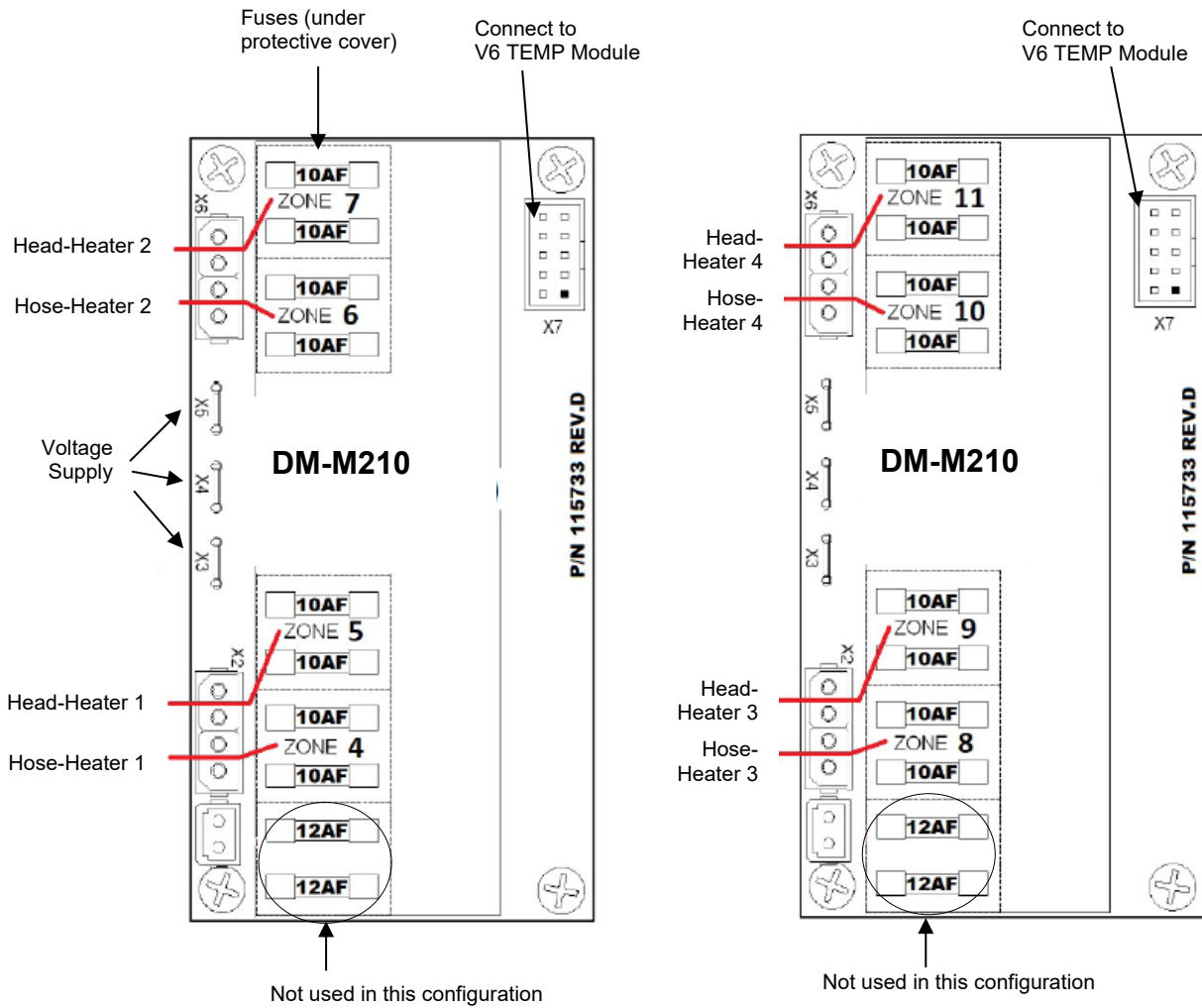

Further options on next page.

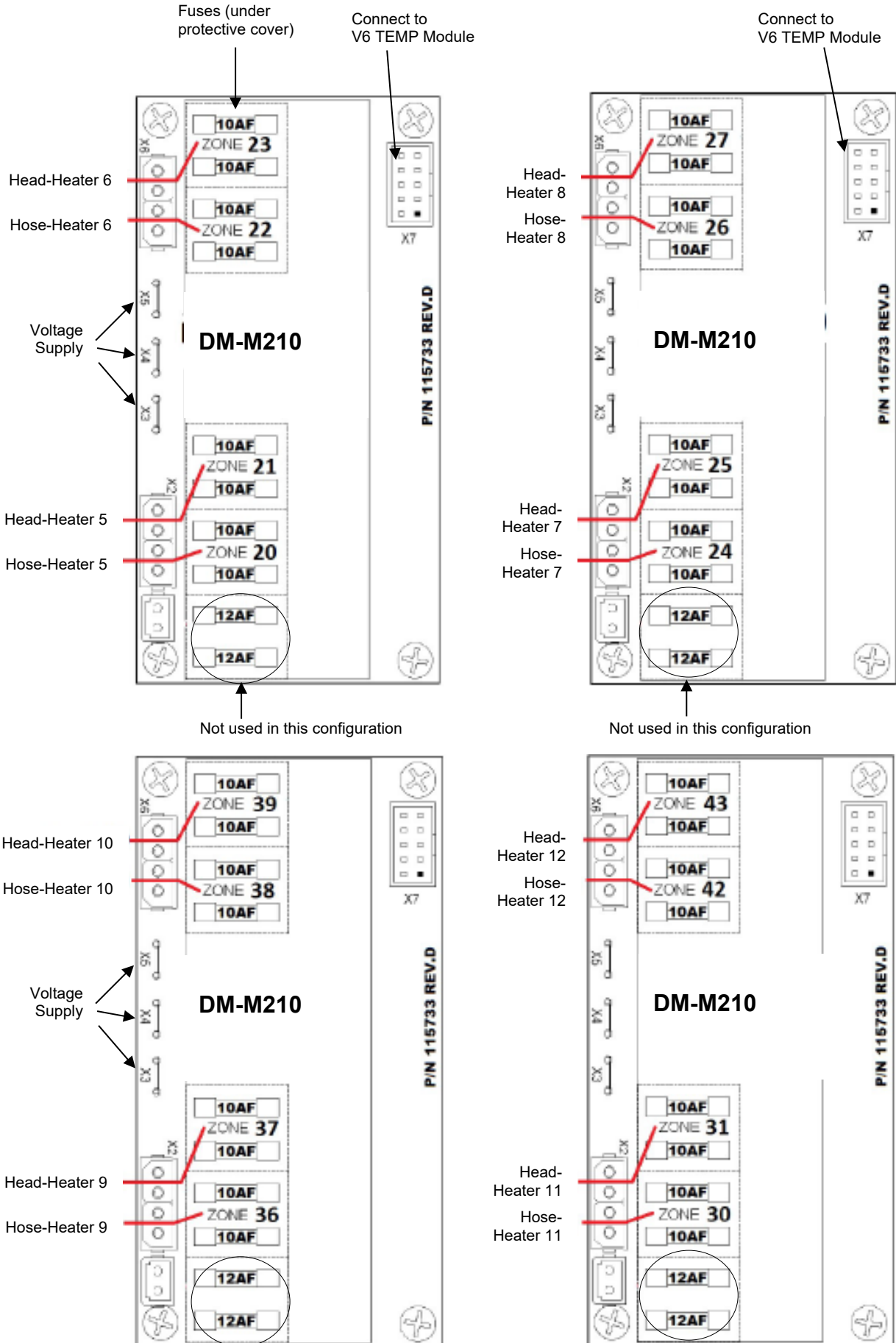

7.5 V6-Motor Module PN 116823

A maximum of two V6 MOTOR modules may be installed on the Melter. Each motor module controls up to four motors. Each motor control output is associated with an enable contact and an encoder input. A wide variety of encoders (i.e. a ring kit) may be adapted to the input.

Each motor may be assigned its individual line speed input, but it is also possible to use a common line speed input. This also applies to the pump enable input. Each motor module has four pressure transducer inputs; transducer type is 4-20mA. One or two pressure transducers may be assigned to each motor.

- Motor #1 on the first Motor Module = pump #2 in the system (pump #1 is on the Base Module).
- Motor #1 on the second Motor Module = pump #6 in the system.

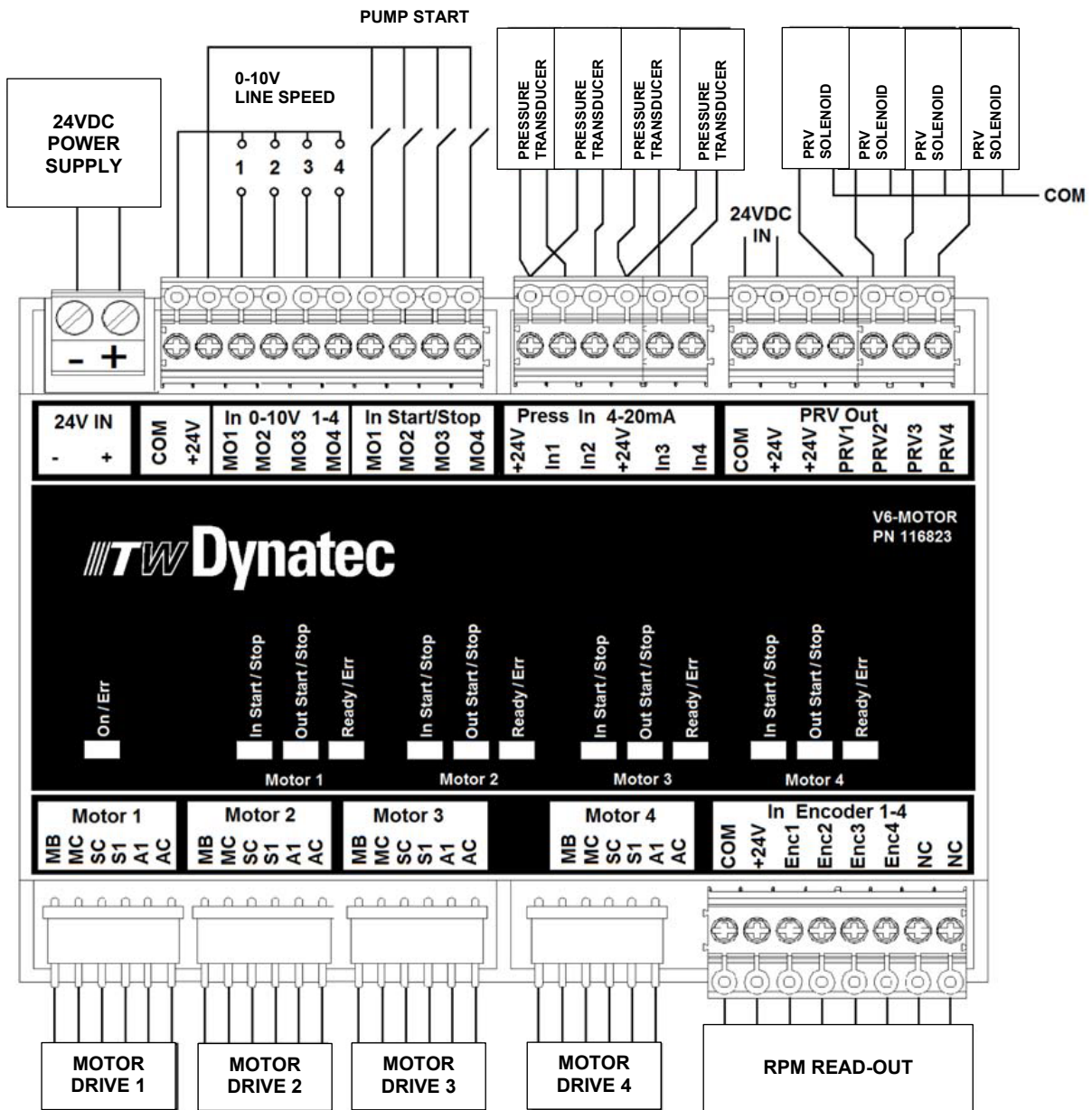

7.6 Motor Speed Control Drive

The Motor Speed Control is mounted on the divider panel within the electronics compartment of the Melter. This variable-frequency drive is factory-set and normally does not require adjustments. The following is a list of parameters that Dynatec programs to optimize performance, but which differ from the drive's default parameters.

Parameter	Value	Description
B1-17	01	Starts the motor even when the enable signal precedes power up.
C1-01	3.0	The time it takes to ramp the pump speed up from 0 to maximum.
C1-02	1.0	The time it takes to ramp the pump speed down from maximum to 0.
C6-02	3	Carrier Frequency 8kHz.
E1-04	62*	Calibrates the maximum speed. See note below for details.
E1-08	16.0	Middle Output Frequency Voltage.
E1-09	2.0	Allows the motor turn down to 1% minimum.
E1-10	9.5	Minimum Output Frequency Voltage.
E2-01	1.5 (1/4HP) or 3.6 (1HP)	Full load amperes, maximum motor current.
L1-01	02	Prevents false tripping at low speeds.
L2-01	02	Does not stop the motor when under-voltage is detected (power up after short interruption).
H2-01	10e	Alarm output on fault, inverted

* Due to component tolerances, the maximum speed of the pump might vary. In order to calibrate the maximum speed, parameter E1-04 can be fine-tuned. Valid range is 61 to 63. Set motor speed to 100% and adjust parameter E1-04 so that the pump is turning exactly 90rpm.

Acceleration and Deceleration Times

The acceleration and deceleration times are factory set to 10 seconds. If an application requires faster acceleration/ deceleration, corresponding parameters can be changed.

Corrupted Memory

If the memory becomes corrupted:

1. Restore the factory default settings by entering 2220 at parameter A1-03.
2. Re-enter the ITW Dynatec parameters specified in the chart at the top of this page.

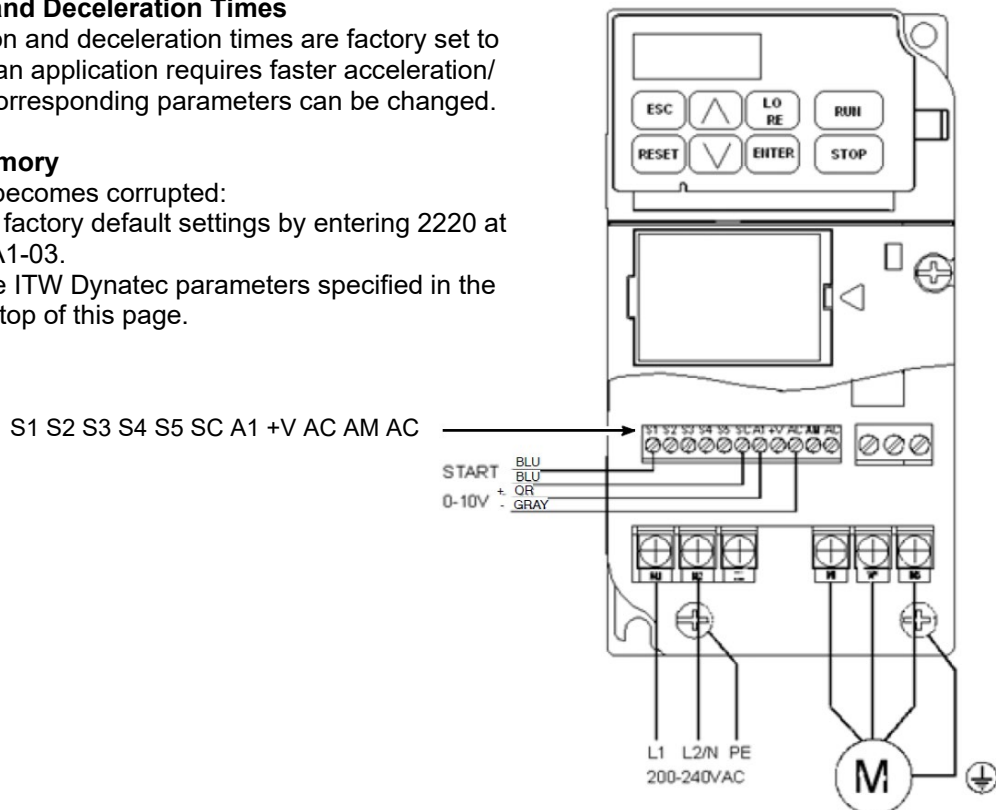



Layout of Motor Control Drive

7.6.1 Accessing, Programming and Monitoring Motor Control Parameters



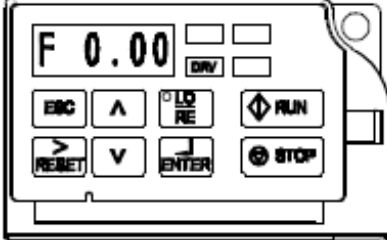

To Access and Change Parameter Values

J1000 Digital Operator power-up state →

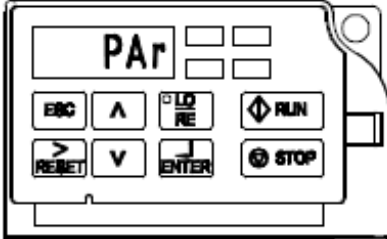





Step 1. Press the  key once. The digital operator shows the parameter menu (PAR), then press the  key.

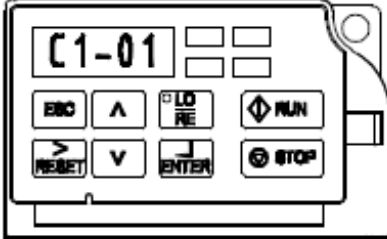

Step 2. Press the  key to select the digit you would like to change. Next use the  and  keys to select the parameter group, sub-group or number, then press the  key.

Select Parameter Menu



Step 3. Press the  key to select the digit you would like to change. Modify the parameter value using the  and  key and press the  key to save the new value.

Select Parameter

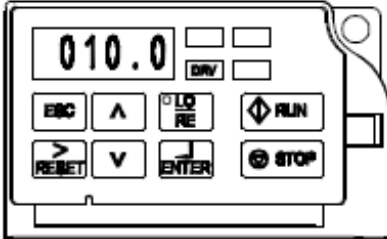

Change Parameter Value

To access other drive signals, refer to the Yaskawa technical manual, available at:
<https://www.yaskawa.com/products/drives/industrial-ac-drives>

7.7 V6-Solid State Relay (SSR) Adapter PCB Assembly PN 118584

The V6 SSR-Adapt Assembly allows 24VDC solid state relays to be connected to the V6 control system. The adapter connects to ribbon cable from #X13, X12 and X11 on the V6 Temperature Module to the V6 Power Modules.

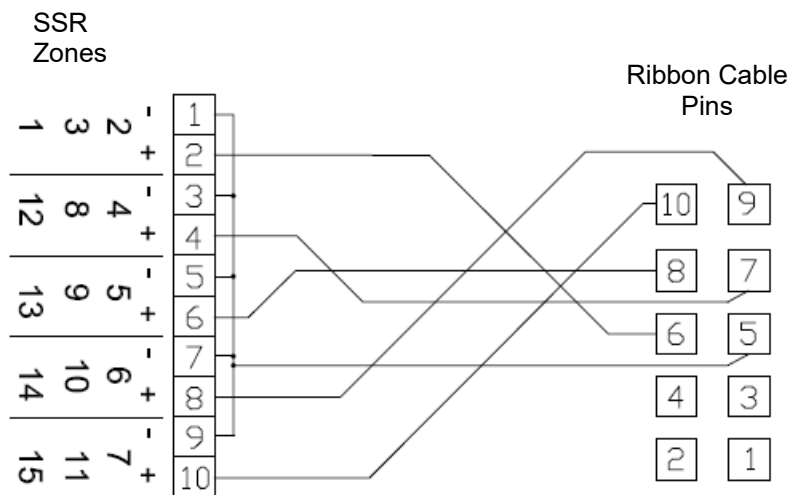
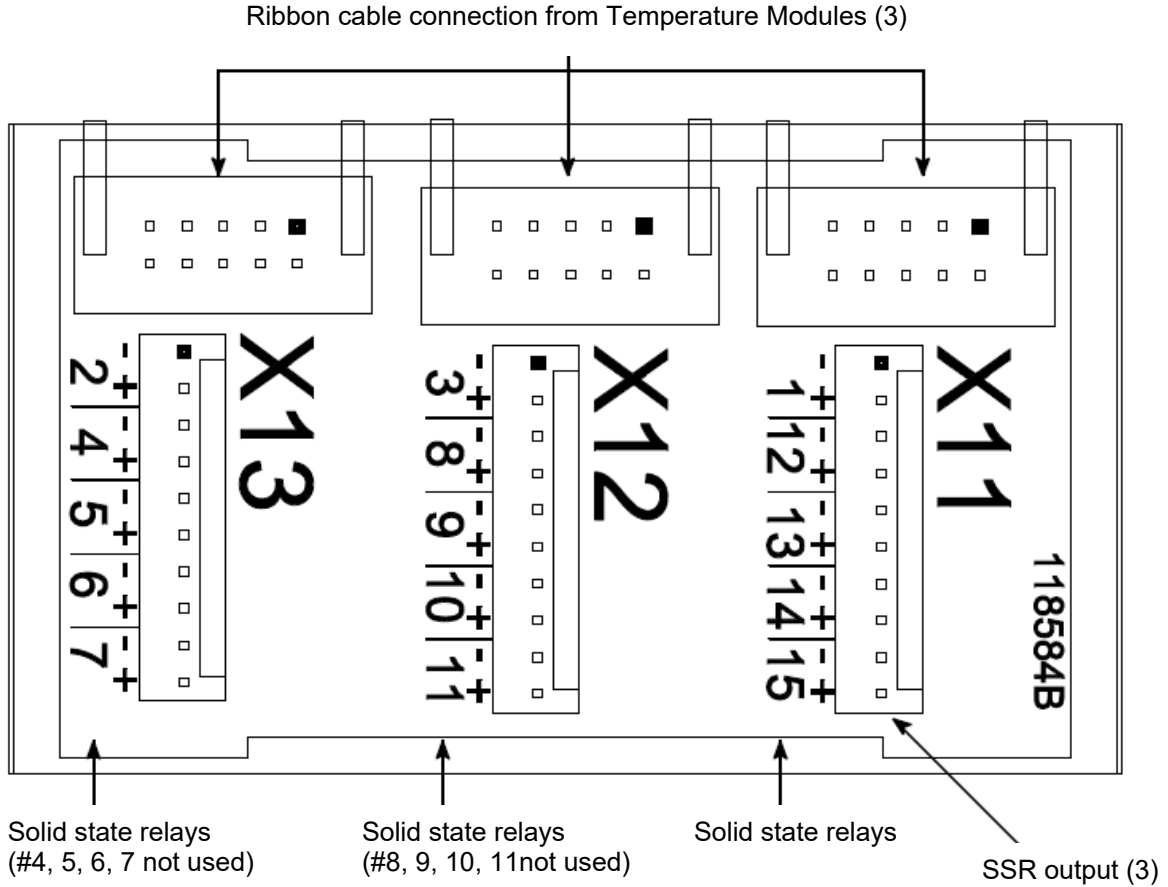

7.8 Optional V6-BUS Communications Module, PN 118125

The V6 BUS module is used with a communications protocol adapter to provide functionality so that the Melter may be operated remotely. Several communication adapters are available, including Ether-Net IP, EtherCat and Profibus.

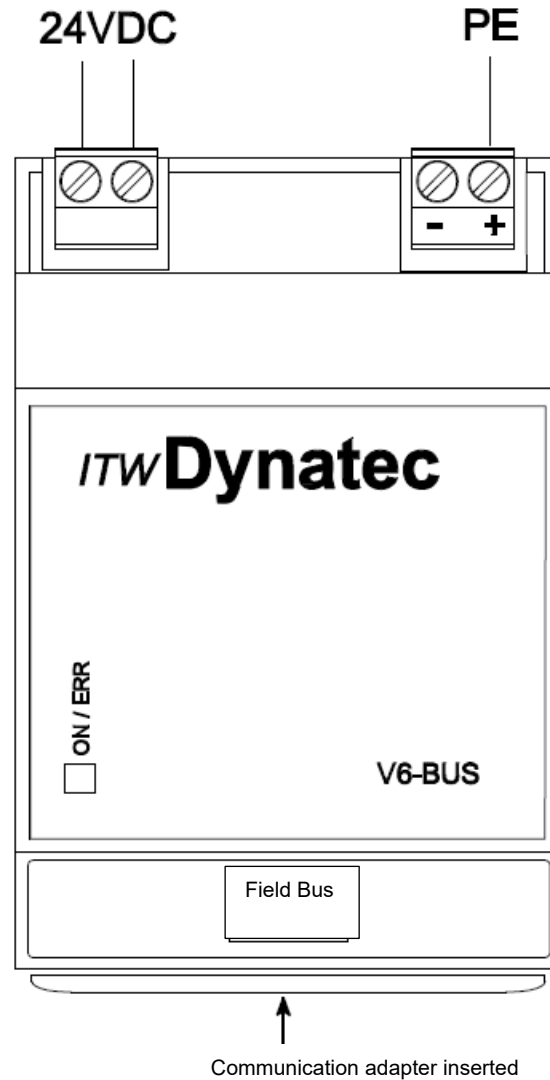

7.9 V6-Extended I/O Module, PN 117648

The V6-XIO Module provides additional inputs and outputs that can be configured for applications that need more I/Os than the Base Module supplies.

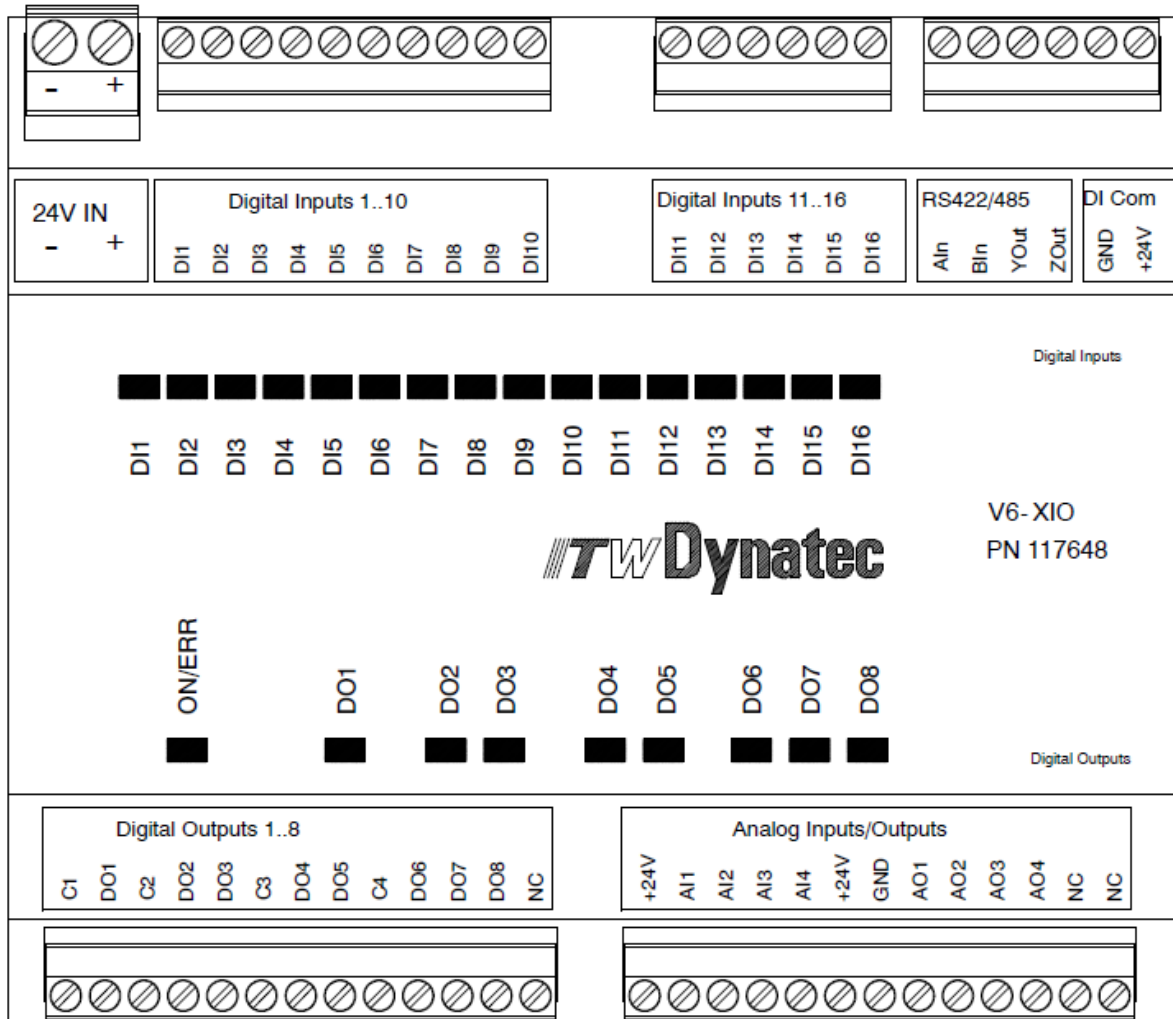

7.10 Optional Printed Circuit Boards

Wiring diagrams and other details on the following optional PCBs/options can be found on the main Melter schematic in Chapter 11:

- Adhesive Level Sensor (hopper low level detection)
- Stack Light (system status lights)
- Signal Isolator (gear pump auto mode)
- Trigger Switch Pump Enable (hand-held applicators/ swirl kits)

7.11 Heater and Sensor Resistance Values

The resistance values given in the four tables on the following page will aid in troubleshooting if a sensor or heater malfunction is suspected.



DANGER HIGH VOLTAGE

Before unplugging connectors from the PCBs, ground yourself to the Melter by touching any available unpainted cool metal surface, mounting screws, etc. This will avoid electrical discharge to the PCB assembly when you are removing and replacing connectors.

Note: Resistance is measured at ambient temperature (20°C/ 68°F).

- The “**Temperature Sensor Resistance**” table gives values for various temperatures. If you know the approximate temperature of the suspected sensor, you can check to see if the sensor resistance approximates the value given in the table by unplugging the affected head or hose connection and measuring resistance across the affected pins (see wiring diagram in Chapter 11 for pin numbers).

Temperature Sensor Resistance (0.00385 PT 100 RTD):

Temperature °F	Temperature °C	Resistance in Ohms
32	0	100
50	10	104
68	20	108
86	30	112
104	40	116
122	50	119
140	60	123
158	70	127
176	80	131
194	90	135
212	100	139
230	110	142
248	120	146
268	130	150
284	140	154
302	150	157
320	160	161
338	170	164
356	180	168
374	190	172
392	200	176
410	210	180
428	220	183

- The “**Nominal Hose Heater Resistance**” table gives the heater resistance for hoses. A suspected hose heater problem can be quickly isolated by measuring hose heater resistance and comparing it to the correct resistance for your hose length and voltage as shown.

Nominal Hose Heater Resistance for #6 DynaFlex-Hoses:

Hose Length		Resistance in Ohms (240V)
Meter	Feet	
1.2	4	466-544
1.8	6	279-326
2.4	8	236-275
3	10	189-221
3.7	12	155-181
4.9	16	118-137
7.3	24	77-90

- The “**Nominal Head Heater Resistance**” table gives values for several different head wattages. A suspected head heater problem can be isolated by measuring head heater resistance and comparing it to the resistance for the appropriate wattage of your system.

Nominal Head Heater Resistance:

Watts	Resistance in Ohms (240V)
200	288
270	213
350	165
500	115
700	82

- The “**Nominal Hopper Heater Resistance**” table gives heater resistance for the hopper heaters and for the (optional) drop-in grids.

Nominal Hopper Heater Resistance:

Melter’s Heaters	M210 in Ohms
Quantity Hopper Heaters	3
Max. numbers of Drop-in Grids	6
Resistance in Ohms for each Hopper Heater	11.5
Resistance in Ohms for each Drop-in Grid Heater	23

- The “**Nominal Filter Manifold Heater Resistance**” table gives heater resistance for the filter manifold heaters.

Nominal Filter Manifold Heater Resistance:

No. Hose Outlets per Filter Manifold	M210 in Ohms
1-2	115.2
3-4	51.6

7.12 Error Indication Alarm Troubleshooting Guide

The operation of error indication alarms is described in Chapter 5. When checking for correct equipment operation in the following guide, be aware that all heaters will go off immediately after an error indication alarm occurs if the operator takes no action. With the exception of the fuses, there are no user-replaceable parts on the printed circuit boards. If there is a non-fuse failure on any of the PCBs, the PCB must be replaced.



Heed all security advices given in Chapter 6.1. Refer to the schematics in Ch. 11 for V6 module connection details.

NOTE: The temperatures measured on the outer surface may deviate significantly from the temperatures set and displayed. This can lead to a false conclusion (e.g. defective heating). Such a difference is normal and depends also largely on the materials used.



DANGER HIGH VOLTAGE

Some of the procedures in the following Troubleshooting Guide require potentially dangerous electricity to be present. Only qualified service personnel should perform these procedures.

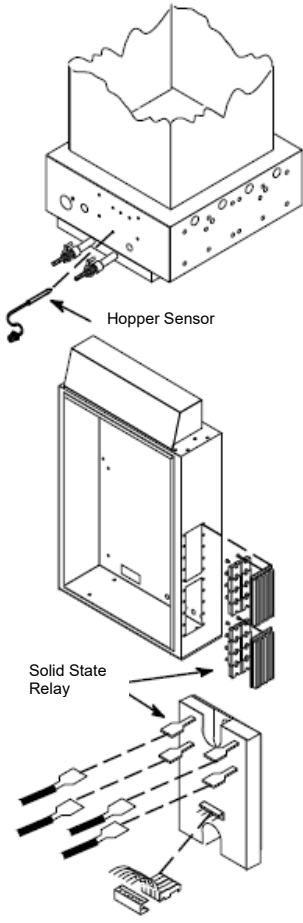
Problem	Possible Cause	Solution
Hopper (Tank) Overtemp  <p>The diagram illustrates the components involved in the 'Hopper (Tank) Overtemp' problem. It shows a hopper with a 'Hopper Sensor' connected to its base. Below, a control panel is shown with a 'Solid State Relay' connected to various terminals. Wires are shown connecting the relay to the heater terminals.</p>	1. Setpoints have been programmed without enough deviation.	1. Re-program setpoints, allowing a larger deviation between the high and low limits.
	2. Hopper sensor inoperative.	2. Replace hopper sensor if resistance does not comply with the resistance table in this manual.
	3. Hopper control solid state relay inoperative.	3. a. Verify that the relay is not shorted by removing all of its output wires and verifying that resistance is greater than zero. b. Verify condition of relay by disconnecting, then re-connecting properly. Then, when Temperature Zone is OFF, use an AC voltmeter to verify that 240 volts are not present at the heater terminal.

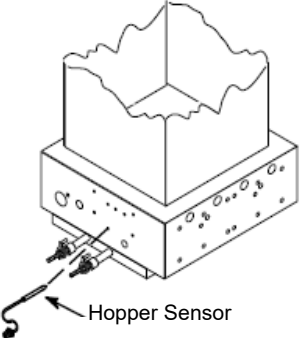
Problem	Possible Cause	Solution
<p>Hopper Sensor Open</p> 	<p>1. Sensor cable has become unplugged from V6 Temperature Module.</p>	<p>1. Verify that hopper sensor cable is properly connected at X3 on the V6 Temperature Module.</p>
	<p>2. Hopper sensor inoperative.</p>	<p>2. Replace hopper sensor if resistance does not match resistance table in this chapter.</p>
<p>Hopper Sensor Short</p>	<p>1. Short-circuit caused by debris where sensor plugs into the V6 Temperature Module.</p>	<p>1. Verify that sensor plug is clean and correctly connected at X3 on the V6 Temperature Module.</p>
	<p>2. Pinched sensor lead wire.</p>	<p>2. Visually inspect sensor lead wire for break, kink, damage, etc. If no obvious damage, use an Ohmmeter to measure continuity from the sensor lead to the plug at the V6 Temperature Module. Repair or replace any damaged wire.</p>
	<p>3. Hopper sensor inoperative.</p>	<p>3. Replace hopper sensor if resistance does not comply with resistance table in this chapter.</p>

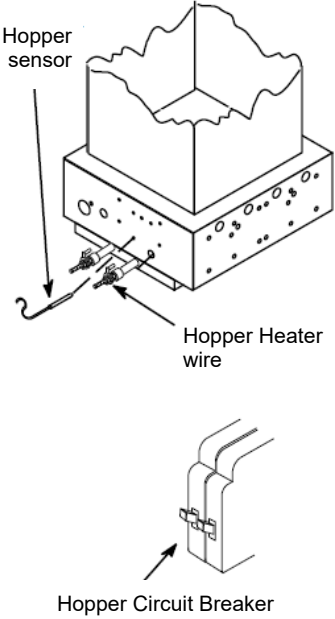
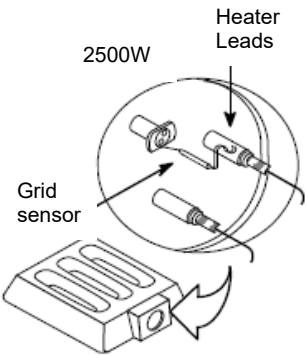
Problem	Possible Cause	Solution
<p>Hopper Heater Open</p>  <p>The diagram shows a hopper heater assembly. A label 'Hopper sensor' points to a sensor on the left side of the hopper. 'Hopper Heater wire' points to the wiring on the front panel. 'Hopper Circuit Breaker' points to a breaker on the front panel.</p>	<ol style="list-style-type: none"> 1. Disconnection in hopper heater circuit. 2. Disconnection between Power Module and the Temperature Module. 3. Hopper circuit breaker tripped. 4. Open hopper heater element. <p><i>NOTE:</i> DM210 models may have up to three hopper heaters.</p>	<ol style="list-style-type: none"> 1. Inspect hopper heater wiring for proper connections. 2. Verify that all connections are properly made between the Power Module and Temperature Module. 3. Refer to the schematic in Chapter 11 to locate the hopper circuit breaker. If it is tripped, do not re-set it without checking for causes. Visually and electrically inspect for a short-circuit to ground in the hopper heater circuit. This will be limited to between the hopper control relay and the hopper heater. 4. At the terminal rail: use an Ohmmeter to measure resistance across H8A and N (400V) or across H2A and H2B (240V). See the resistance table in this chapter for normal resistance values. Infinitely high resistance values indicate an open heating element which must be replaced. <p>If the Melter has a second heater, measure this heater's resistance across H18A and N (400V) or across H18A and H18B (240V) as outlined above.</p> <p>If the Melter has a third heater, measure this heater's resistance across H28A and N (400V) or across H34A and H34B (240V) as outlined above.</p>
<p>(Optional) Drop-in Grid Overtemp</p>  <p>The diagram shows a 2500W heater. 'Heater Leads' points to the wires connected to the heater. 'Grid sensor' points to a sensor on the heater's surface.</p>	<ol style="list-style-type: none"> 1. Setpoints have been programmed without enough deviation. 2. Grid sensor inoperative. 3. Grid control solid state relay inoperative. 	<ol style="list-style-type: none"> 1. Re-program setpoints, allowing a larger deviation between the high and low limits. 2. Examine grid sensor assembly for intermittent break in sensor lead. Remove sensor bulb from grid. Replace grid sensor if resistance does not comply with the resistance table in this chapter. 3. Use a clamp-on ammeter to monitor current. Replace inoperative solid state relay.

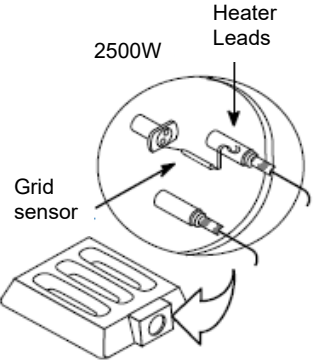
Problem	Possible Cause	Solution
(Optional) Drop-in Grid Sensor Open	1. Sensor cable has become unplugged from Temperature Module.	1. Verify that grid sensor cable is properly connected at X2 on the V6 Temperature Modules.
	2. Disconnection between Power Module and the Temperature Module.	2. Verify that all connections are properly made on the V6 Temperature Module(s).
	3. Drop-in grid sensor inoperative.	3. Replace sensor if resistance does not comply with the resistance table in this chapter.
(Optional) Drop-in Grid Sensor Short	1. Short-circuit caused by debris where sensor plugs into the Temperature Module.	1. Verify that sensor plug is clean and correctly connected at X2 or X10 on the V6 Temperature Module(s).
	2. Pinched sensor lead wire.	2. Visually inspect sensor lead wire for break, kink, damage, etc. If no obvious damage, use an ohmmeter to measure continuity from the sensor lead to the plug at X12 or X13 on the V6 Temperature Module(s). Repair or replace any damaged wire.
	3. Drop-in grid sensor inoperative.	3. Replace sensor if resistance does not comply with the resistance table in this chapter.
(Optional) Drop-in Grid Heater Open 	1. Disconnection in grid's heater circuit.	1. Inspect grid's heater wiring for proper connections.
	2. Disconnection between Power Module and solid-state relay.	2. Verify that the V6 Power Module is properly connected to the solid-state relay.
	3. Drop-in grid circuit breaker tripped.	3. Refer to the schematic in Chapter 11 to locate the grid's circuit breaker. If it is tripped, do not reset it without checking for causes. Visually and electrically inspect for a short-circuit to ground in the grid's heater circuit. This will be limited to between the grid's control relay and the grid's heater.
	4. Open drop-in grid heater element. NOTE: The M210 Melter may have from 1 to 6 grids.	4. At the terminal rail, use an ohmmeter to measure resistance as follows: For 1 grid: H1A & N (400V) H1A & H1B (240V) For 2nd grid: H10A & N (400V) H16A & H16B (240V) For 3rd grid: H11A & N (400V) H17A & H17B (240V) For 4th grid: H20A & N (400V) H32A & H32B (240V) For 5th grid: H21A & N (400V) H33A & H33B (240V) For 6th grid: H30A & N (400V) H48A & H48B (240V) See the resistance table in this chapter for normal resistance values. Infinitely high resistance values indicate an open heating element which must be replaced.

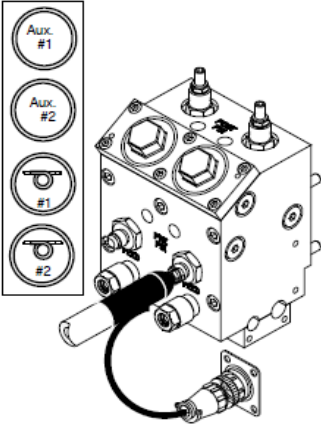
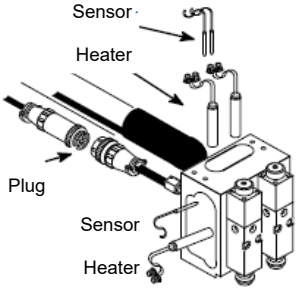
Problem	Possible Cause	Solution
<p>Hose/ Head (No.*) Overtemp</p> <p><i>* Check each Hose/Head circuit on the system.</i></p> <p>Note: Vertical hose configuration is for DM 35 only. Larger Melters are arranged horizontally.</p>  	<p>1. Hose/ Head setpoints incorrectly programmed.</p>	<p>1. Re-program setpoints to allow a larger deviation.</p>
	<p>2. Hose/ Head triac on Power Module is inoperative.</p>	<p>2. If a hose or head status LED on the V6 Temperature Module is OFF, and the corresponding temperature continues to rise, the corresponding triac on its V6 Power Module has failed. The module must be replaced.</p>
	<p>3. Disconnection between the Power Module and the Temperature Module.</p>	<p>3. Verify that the circuit breaker and the V6 Power Module are connected properly. Check the ribbon cable connection between the V6 Temperature Module and the V6 SSR Adapter and V6 Power Module.</p>
	<p>4. Hose/ Head sensor circuit inoperative.</p>	<p>4.</p> <ul style="list-style-type: none"> a. Visually examine socket connection where hose/ head attaches to Melter. Verify that pins are properly seated. If pins or plug housing are damaged, repair or replace hose. If socket is damaged, repair or replace harness. b. If hose-to-Melter plug and socket are okay, hose may have intermittent short or open circuit. Repair or replace hose, hose harness or V6 Power Module as appropriate. Alternately, problem can be isolated by connecting the effected hose to a different Melter hose socket to tell whether the problem is in the hose or in the V6 Power Module. c. If head-to-hose and hose-to-Melter plugs and sockets are okay, head sensor may have an intermittent short or open circuit. Examine connections inside the service block area of the head and monitor head sensor resistance with an ohmmeter while flexing sensor leads. Repair or replace as appropriate.

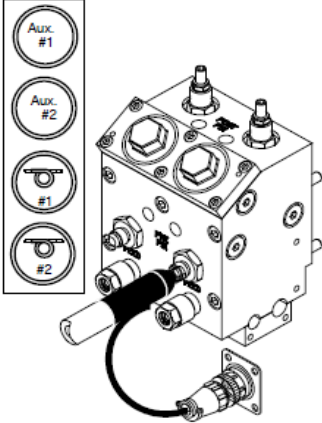
Problem	Possible Cause	Solution
<p>Hose/ Head (No.*) Not Heating (Sensor Circuit Open)</p> <p><i>* Check each Hose/Head circuit on the system.</i></p> <p>Note: Vertical hose configuration is for DM 35 only. Larger Melters are arranged horizontally.</p> 	<ol style="list-style-type: none"> 1. Disconnection between hose and Melter. 2. Hose sensor harness unplugged from Power Module. 3. Hose/ Head sensor circuit inoperative. 	<ol style="list-style-type: none"> 1. Visually examine connection where hose plugs into Melter socket for proper contact and seating. If pins or housings are damaged, repair or replace hose or hose harness (in Melter). 2. Verify that affected hose is properly connected to the V6 Power Module. Replace or repair damaged hose harness as necessary. 3. Replace head sensor if resistance does not comply with resistance table in this chapter. Use hose schematic to check hose sensor at Melter socket. Repair or replace hose, hose harness or V6 Power Module as appropriate.
<p>Hose/ Head (No.)* Not Heating (Sensor Circuit Shorted)</p> <p><i>* Check each Hose/Head circuit on the system.</i></p>	<ol style="list-style-type: none"> 1. Debris at connection between hose/ head and Melter. 2. Debris at connection between hose/ head harness and Power Module. 3. Hose/ Head sensor circuit inoperative. 	<ol style="list-style-type: none"> 1. Visually inspect hose plug and Melter socket for cleanliness and proper contact and seating of pins. 2. Visually inspect that the affected hose plug at V6 Power Module is clean and properly installed. 3. <ol style="list-style-type: none"> a. Using the hose schematic, check hose sensor resistance at Melter socket. An ohmmeter can be used to isolate a pinched wire in the hose harness. When cause is isolated, replace hose, hose harness or V6 Power Module as appropriate. b. If head-to-hose and hose-to-Melter plugs and sockets are okay, head sensor may have an intermittent short or open circuit. Examine connections inside the service block area of the head and monitor head sensor resistance with an ohmmeter while flexing sensor leads. Repair or replace as appropriate.

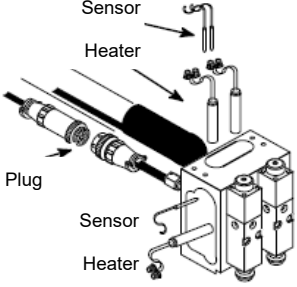
Problem	Possible Cause	Solution
<p>Hose/ Head (No.*) Not Heating (Heater Circuit Open)</p> <p><i>* Check each Hose/Head circuit on the system.</i></p> 	<ol style="list-style-type: none"> 1. Disconnection between hose/ head and Melter. 2. Disconnection between hose/ head harness and Power Module. 3. Disconnection between cartridge heater and cable assembly inside head. 4. Head/ hose fuse on Power Module is inoperative. 5. Open head heater element. 6. Open wiring inside Melter. 	<ol style="list-style-type: none"> 1. Visually examine effected hose plug and Melter socket for cleanliness and proper contact and seating. Refer to the wiring diagram for pin identification. The problem can be isolated by plugging the effected hose/ head into another Melter socket. If the new hose number is then displayed as malfunctioning, the problem is in the hose that was moved. Repair or replace hose, head or Melter hose harness as appropriate. 2. Verify that the hose harness is properly inserted into its plug on the V6 Power Module. Check for loose leads, debris and proper contact. 3. Visually inspect wiring inside head. Verify that cartridge heater leads are properly connected in the service block area. 4. If fuse is found to be blown, do not replace it without first finding cause. Look for a short circuit to ground in the head heater circuit, particularly inside the head at the connections in the service block area. If replaced fuse also blows, the V6 Power Module may be the cause. However, fuse failure is usually due to a problem in the head heater circuit, not the Power Module. See schematic in Ch. 11. 5. Use an ohmmeter to measure head cartridge heater resistance. See resistance table in this chapter for resistance values. Infinitely high resistance indicates an open heater. Replace cartridge heater as appropriate. 6. Visually inspect Melter wiring and use an ohmmeter and the wiring diagram to locate open wires in head heater circuit. Repair or replace Melter hose/ head harness or other Melter wiring as necessary.

7.13 Adjustable Adhesive Pressure Relief Valve

Dynamelt pumps are outfitted with a high-pressure relief valve located on the outlet filter manifold.

The valve is adjustable, and it does not affect adhesive pressure under normal operating conditions. The adjustable pressure relief valve is factory set at 34 bar (500 psi) for Dynamelt M gear pumps.

When adhesive pressure exceeds the set limit, the pressure forces the valve to move away from its seat, compressing the spring and allowing adhesive to flow back to the hopper. This adhesive flow reduces pressure. When the pressure falls below the set limit, the spring forces the valve against its seat, cutting off adhesive flow.

The check valve, seen below, is not instrumental in pressure relief. It serves as an overflow valve, preventing adhesive from flowing out of the hopper when the filter plug is removed.

Normally Closed (Unrelieved):

In the drawing below, the pressure relief valve is closed.

Open (Relieved):

In this drawing, pressure has exceeded the setting of the valve, causing the valve to open and discharge adhesive to the hopper.

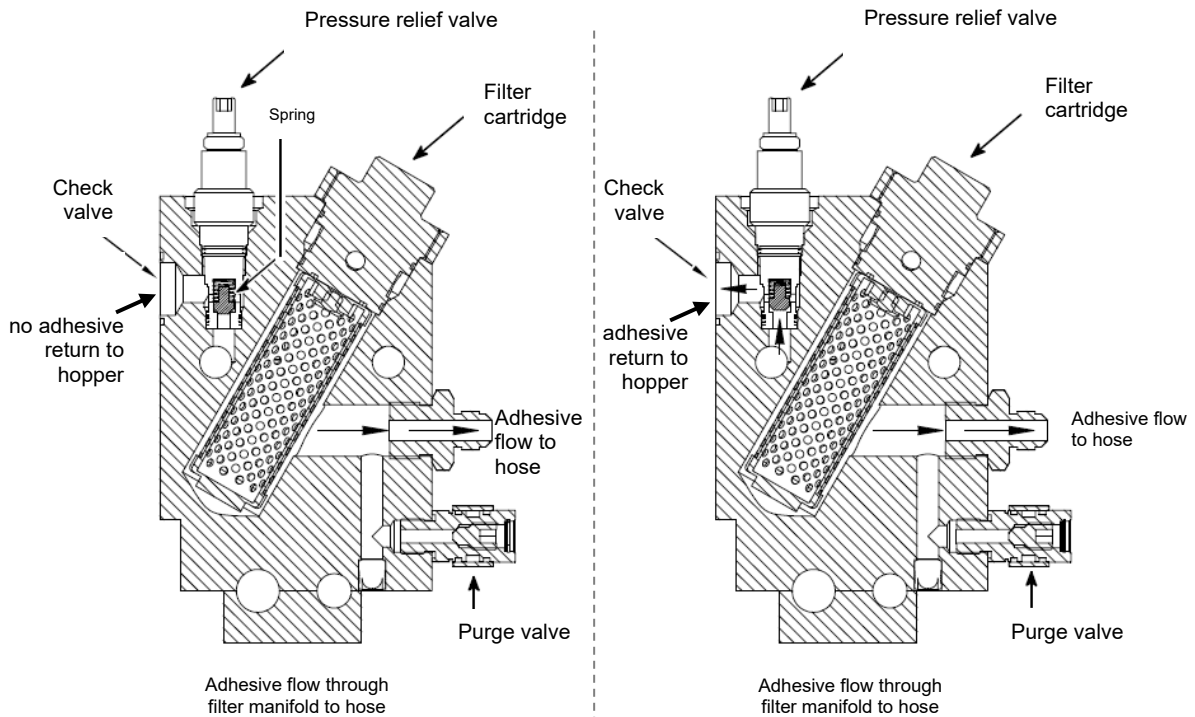

Operation of the Adjustable Adhesive Pressure Relief Valve

7.14 Operation of the Melter's Gear Pump

7.14.1 Manual or Automatic Pump Operation

Choose "Manual", "Stop" or "Automatic" gear pump operation via the Pump Overview Screen on the controller's Touch Screen. When the Dynamelt's pump is to be operated manually (that is, without a line following signal), the manual mode is used to control pump speed (and adhesive output). For the gear pump to be operated in the automatic mode, a parent machine tracking signal (attached to the parent conveyor line) must be provided and the following set-up procedure should be performed:

1. The tach generator or the signal isolator must be adjusted so that the voltage from the speed controller is 0 to 10 VDC (but not more than +10 VDC when the conveyor is at maximum speed). This voltage is measured at either LINE/COM terminals on the BASE Module and/or at In-0-10V-1-4/COM on Motor Module (if tach generator) or at terminals 9 (+) and 10 (-) of the Signal Isolator Board.
2. The "Automatic" setting then changes pump speed for any given 0 to +10 VDC incoming tachometer signal. Voltage will vary given production speed.
3. Digital speed communication is accomplished over a communication (EtherNet IP, Profibus, etc.) connection. This is covered in the programming chapter of this manual.

The motor speed can be adjusted (trimmed) in automatic mode by setting maximum and minimum percent of full speed values on the controller's Touch Screen. MAX % of Full Speed will be the true motor speed at 10 volts input. This value cannot exceed 100%.

To make the motor speed adjustment, follow the programming instructions in Chapter 5.

7.14.2 Pump Output Adjustments

When the adhesive in the Melter's hopper has reached a temperature high enough for the pump to operate safely, the controller will place the hopper in "Ready" condition and power will be supplied to the pump/motor. The pump is self-priming.

Pump output is adjusted by the motor speed control on the controller's Touch Screen. However, if less pressure is needed, maximum pressure of the pump can be decreased (or increased) by adjusting the pressure relief valve installed on the pump output manifold. To change the setting of this valve, refer to instructions in Chapter 3.

The relief valve is factory set at 34 bar (500 psi) for Dynamelt M gear pumps.

7.15 Troubleshooting the Melter's Gear Pump

No special tools are needed for working on the Melter's pump. See Chapter 8 of this manual for disassembly/ assembly procedures for the gear pump, and Chapter 10 for locating pump parts on the component illustrations (exploded-view drawings).

7.15.1 Gear Pump Priming/ Start-Up

The pump is self-priming.



CAUTION

DO NOT continue to run the pump if no glue is coming out. This could damage the pump since it uses the glue as a lubricant. Stop and troubleshoot.



7.15.2 Gear Pump Troubleshooting Guide

 **NOTE:** Please re-read all security advices given in Chapter 2 before performing any troubleshooting or repair procedures.





All troubleshooting or repair procedures must be performed by qualified, trained technicians.

 **Heed all security advices given in Chapter 6.1.**

NOTE: The temperatures measured on the outer surface may deviate significantly from the temperatures set and displayed. This can lead to a false conclusion (e.g. defective heating). Such a difference is normal and depends also largely on the materials used.

  **WARNING HOT SURFACE & HOT ADHESIVE**

Severe burns can occur if unprotected skin comes in contact with molten adhesive or hot application system parts.

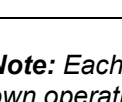
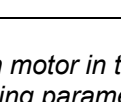
      Some of the procedures in the following Troubleshooting Guide require working near hot adhesive.

Face shields (preferred) or safety glasses (for minimum protection), heat-resistant protective gloves and long-sleeved clothing must be worn whenever working with or around adhesive application systems.

Use proper tools for handling hot melt components.

Note: Each motor in the system can run independently (or dependently). Each motor may have its own operating parameters. Therefore, each motor should be troubleshot independently.

Problem	Possible Cause	Solution
Pump doesn't operate in "Manual" mode.	1. For pump mode the button STOP is pressed at Touch Screen on Pump Control Screen.	1. Check setting at Touch Screen on Pump Control Screen.
	2. Hopper temperature is below ready setpoint.	2. Pump cannot operate until hopper has reached ready condition. Verify that hopper has reached ready. Re-program hopper operating setpoint and ready setpoint if necessary.
	3. No incoming electrical power.	3. Check to see if Melter temperature control is operating. If not, check for presence of incoming supply voltage.

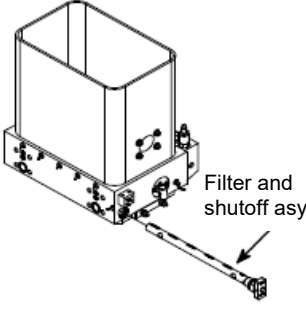
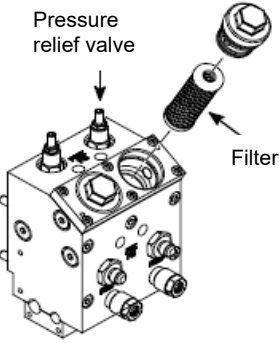
Problem	Possible Cause	Solution
Pump doesn't operate in "Manual" mode, hopper is at Ready condition.	1. "Manual" pump is set at zero RPM (at Touch Screen).	1. Re-program pump.
	2. If pump MANUAL/STOP is being controlled by a remote switch (i.e., a handheld applicator), the switch or switch circuit may be open.	2. Check condition of the remote switch (the hand-held applicator).
	3. Faulty motor controller.	3. If the control is faulty, it must be replaced.
Pump doesn't operate in "Auto" mode, hopper is at Ready condition.	1. Parent machine is not running.	1. Check parent machine.
	2. "Auto" motor is set at zero (at controller keypad).	2. Re-program pump.
	3. No incoming line following signal.	3. Check for presence of 0 to 10 VDC control signal at LINE and COMMON terminals on V6 Base module. If signal is not present, check connection at tachometer drive connections. If control signal is present there, the problem is within the Melter.
Pump runs but there is no adhesive output.	1. Melter is out of adhesive.	1. Add adhesive to hopper.
	2. If pump has been serviced and leads reversed, pump will run backwards with no output.	2. Check pump wiring to schematic.
Low or inconsistent adhesive output.  	1. Filter(s) clogged.	1. Remove and inspect filter basket and filter and shutoff assembly.
	2. Adhesive used is too viscous.	2. Verify that system components are at appropriate temperatures and that the selected adhesive is correct for the application.
	3. Clogged hose.	3. Inspect hose for kinks or internal plugs of debris or char. Clean or replace hoses as necessary.
	4. Clogged applicators.	4. Inspect applicators for plugged nozzles or filters. Clean or repair applicators as necessary.
	5. The fixed pressure relief valve is opening.	5. When fully closed (clockwise) and all applicators are off, adhesive pressure should be around 68 bar (1000 psi). If it is significantly less, the pressure relief valve should be replaced.

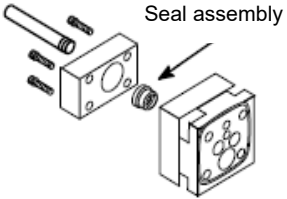
Problem	Possible Cause	Solution
<p>Adhesive leak at pump shaft seal.</p> 	<p>1. Pump seal is incorrectly positioned inside the seal and bearing assembly.</p>	<p>1. Remove seal and bearing from pump. Verify that all components are correctly positioned.</p>
	<p>2. Pump seal inoperative.</p>	<p>2. Remove seal from pump, inspect it and replace it if worn or damaged. Be sure there are no burrs or other sharp edges on pump shaft or on installation tools that could damage a new seal.</p>
<p>Adhesive leak at pump-to-hopper interface.</p>	<p>1. O-ring in pump's rear plate is inoperative.</p>	<p>1. Remove seal from pump, inspect it and replace it if worn or damaged. Be sure there are no burrs or other sharp edges on the rear plate o-ring groove that could damage a new o-ring.</p>
	<p>2. Pump retaining nuts are missing or loose.</p>	<p>2. Verify that all four pump retaining nuts are tightly assembled to the studs.</p>
	<p>3. Helicoil insert pulled out of hopper.</p>	<p>3. Remove pump and inspect hopper. Repair or replace hopper as necessary.</p>

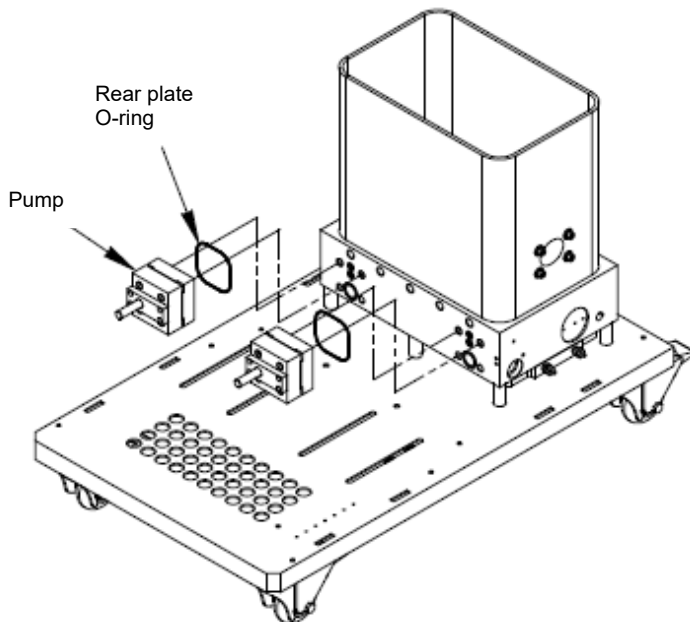

Chapter 8

Disassembly & Re-assembly Procedures

8.1 Disassembly Procedures



NOTE: Please re-read all security advices given in Chapter 2 before performing any troubleshooting or repair procedures.

All Disassembly & Re-assembly Procedures must be performed by qualified, trained technicians.



DANGER HIGH VOLTAGE

The Dynamelt Melter uses electrical power that can be life threatening.

Once the system is up to temperature, disconnect and lockout all incoming power before proceeding.



WARNING HOT SURFACE

The Dynamelt Melter uses hot-melt adhesives that can cause serious burns.

Severe burns can occur if unprotected skin comes in contact with molten adhesive or hot application system parts.

Some of the procedures in the following Troubleshooting Guide require working near hot adhesive.

Face shields (preferred) or safety glasses (for minimum protection), heat-resistant protective gloves and long-sleeved clothing must be worn whenever working with or around adhesive application systems.

Use proper tools for handling hot melt components.



Note: Use the exploded-view drawings referenced with each procedure in conjunction with the instructions outlined in this chapter. Read the cautions "Re-assembly Procedures" in this chapter before re-assembling the Melter.

8.2 To Remove the Access Doors

There are two access doors, one on either side of the Melter. See Melter illustration on next page.

- Use the key to unlock the door, then lift it off, being careful not to pull off the ground wire attached.
- Remove the ground wire and re-attach when the door is re-installed.

These doors allow access to the motor, pump, junction box, (optional) drop-in grids, filter and shutoff assembly and (optional) ball valve.

8.3 To Open Junction Box

There are two junction boxes, one on either side of the hopper(s). A junction box cover is removed by two screws at the bottom of the box. Within the junction boxes are thermostats, heater terminals and the hopper sensor. See also the detailed illustration on the following page.

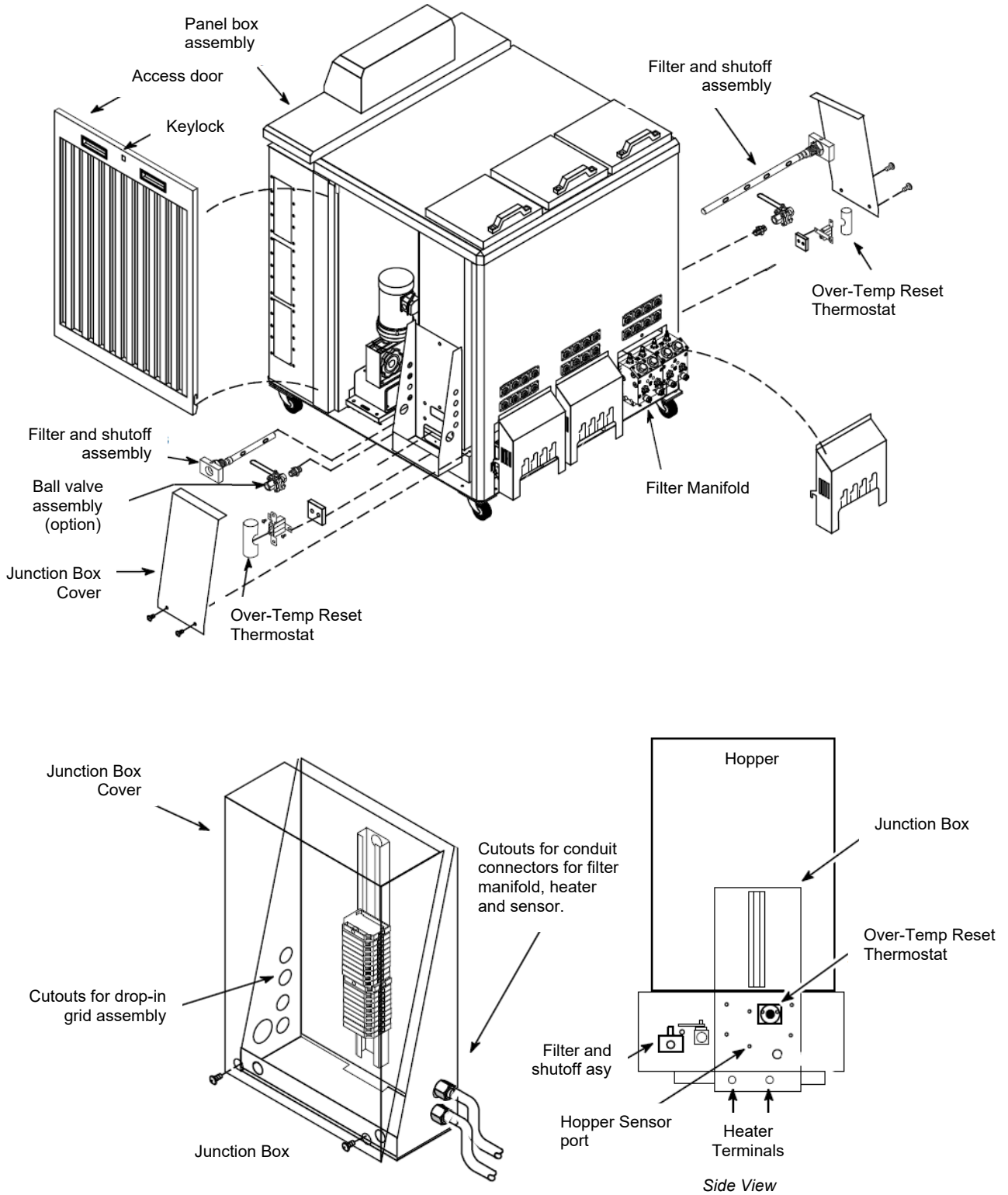

Illustration: Melter

8.4 Sensor or Thermostat Replacement

Remove the junction box cover.

a. Over-Temperature Thermostat Replacement:

Remove the two screws and slip the terminals and the hopper ground wire off of the thermostat before removing the thermostat from the base of the hopper.

b. RTD Sensor Replacement:

Disconnect two wires from the terminal strip and slide the sensor out.

8.5 To Remove the Manifold Cover

- Unscrew its captive screw and slide cover up and off.

Cover allows access to the hose connections on the filter manifold, outlet filters, heaters and the pressure relief.

8.6 Heater Replacement

The M210 models have three heater plates. The heater plates are located underneath the hopper(s):

- Remove the access door.
- Use a hex head socket wrench to remove the six heater plate bolts through the holes drilled in the base plate.
- Disconnect the heater wires.
- Slide the old heater plate out.
- Connect heater wires to new plate.
- Slide new plate in place and fasten with the six bolts.

The cartridge heaters are located underneath the filter manifolds:

- At the rear of the Melter, remove the filter manifold cover.
- Remove the cover located at the end of the heater retainer plate (4 screws).
- Disconnect heater wires from the terminal rail.
- Loosen the heater retainer plate and slide the cartridge heaters out.

8.7 To Remove Rear Cover

No customer replaceable components are behind the rear cover.

To remove the rear cover:

- Remove the two access doors in order to access.
- Remove the five screws which hold the rear cover in place. Two screws are located in the upper corners of the rear cover. Three screws are located across the bottom of the cover.

8.8 To Access the RTD Sensor in the Optional Drop-in Grid

- Remove the access door.
- Remove the screws on the drop-in grid's junction box cover in order to remove the cover.
- Disconnect the sensor from the terminal strip inside the junction box and slide the sensor out of its adapter.

8.9 To Access Electrical Components inside the Panel Box



DANGER HIGH VOLTAGE

The Dynamelt Melter uses electrical power that can be life threatening.

Disconnect and lock out input power to the application system before starting any disassembly procedure.

Verify again that the main power is OFF. On the outside of the panel box, use the main disconnect switch to open panel box door (see Chapter 3 for instructions for opening door).

a. Fuse Replacement: Fuses are located in the upper right corner of the inside of the panel box assembly. The V6 Power I/O module is the only module or PCB with fuses. These fuses may be removed after removing the PCB's protective cover.

b. Power Printed Circuit Board Replacement: Reference the section entitled "Handling Printed Circuit Boards" in Chapter 7. The Power PCBs are located in the panel box assembly, in the side of the panel box. Refer to detailed layout in Chapter 3.

The Power I/O PCBs are attached to the side of the panel box by four screws. Remove all wiring connectors before removing.

c. Module Replacement: Reference the section entitled "Handling Printed Circuit Boards" in Chapter 7.

The V6 Modules are installed on a DIN rail. To remove a module, first unplug all connectors attached to it.

1. Unscrew the end stop of the DIN rail nearest to the desired module and slide it off the rail.
2. Gently slide the modules apart on the rail (you may need to unplug some connectors to do this).
3. Each module is "locked" onto the rail by two orange connectors at the top and bottom of the module. With a flat-blade screwdriver, slide the upper orange connector up until it clicks open, and slide the lower orange connector down until it clicks open. Then the module may be lifted off the rail.

Note: aside from the fuses on the Power PCB(s), there are no replaceable parts on the modules or PCBs.

d. Opening Modules

There are various electrical components located within the modules.

To open a module, use two fingers to pull straight up on the top (lid) of the module.

Position your fingers toward the outside edge (not the center) of the module.

Do not use a tool as it could damage the module's plastic casing.

8.10 To Access the Pump or Motor



DANGER HIGH VOLTAGE & HOT SURFACE

- If the pump is not operable but the heating system will function, raise the temperature of the application system to the operating temperature to aid in the pump disassembly process. Otherwise, a heat gun or other controlled heating method is recommended to melt hardened hot melt material.
- Never use a torch or an open flame on any of the components of the application system.
- Once the system is up to temperature, disconnect all incoming power before proceeding.

- Remove access door(s) using the key, being careful not to pull off the ground wires attached.
- Turn OFF the filter and shutoff assembly by turning it to its closed "0" position.

a. Motor Removal:

- Open the motor junction box cover (2 screws).
- Inside the junction box, disconnect the wires leading to the motor.
- On the outside of the junction box, unscrew the hex nut on the cord grip.
- Slide the wires through the conduit fitting.
- Remove the four bolts which attach the motor to the gear box.
- Lift the motor up and out of the Melter.

For re-assembly:

Torque should be approximately 1.8 Nm (16 foot/lbs) at room temperature. With hopper at 177°C (350°F), the maximum allowable torque on screws is 4.1 Nm (36 ft/lbs).

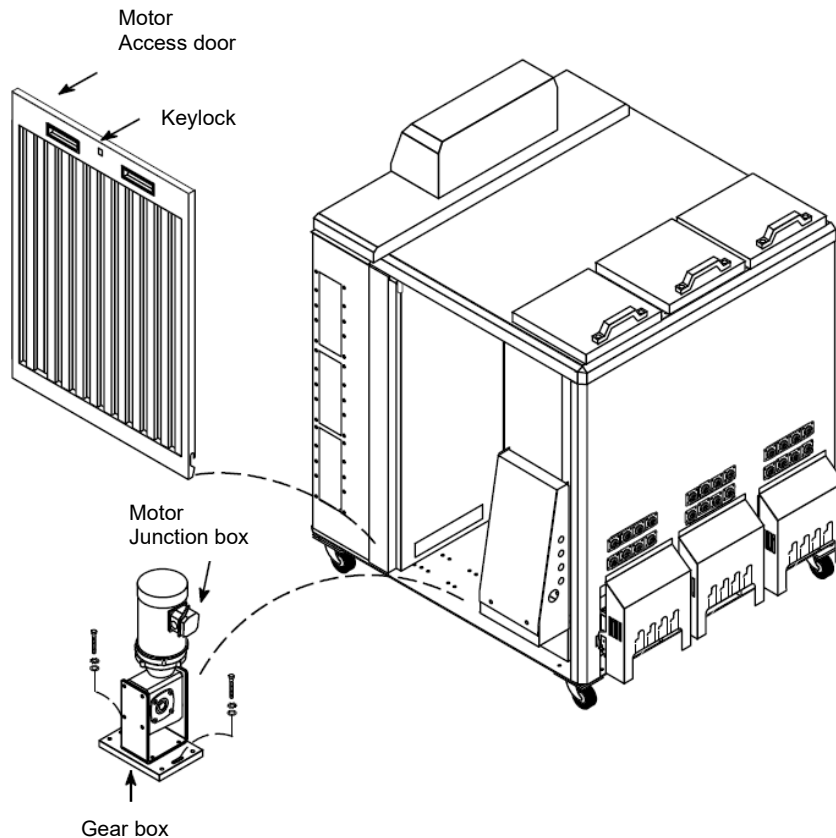

b. Pump Removal:

Verify that the filter and shutoff assembly is in its closed "0" position. Remove the release pin and retainer clip, slide the shaft out of the gear box. Slide the coupling off the pump shaft. Remove the four pump mounting bolts.

c. Pump Seal (O-ring) Replacement:

Remove the pump from the Melter (see instructions above, "b"). Remove the external pump seal from its groove on the back of the pump adapter plate (this is the seal located between the adapter plate and the hopper). Install the new seal.

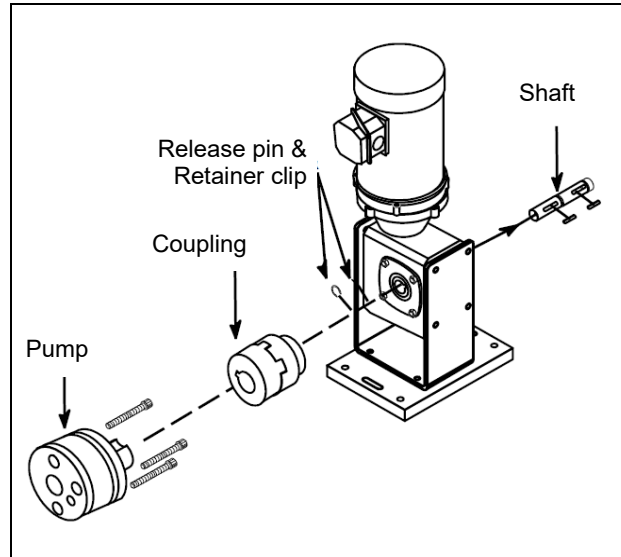
**8.11 Re-Assembly Procedures**

Unless noted, the Melter's re-assembly is simply the reverse sequence of the disassembly procedures. However, the following "cautions" should be followed (whenever they apply) for proper re-assembly:

**WARNING HOT SURFACE**

In order to protect personnel and equipment, it is important to replace all insulation whenever it is removed from the Melter.

**CAUTION:**

- In general, all O-RINGS AND SEALS should be replaced whenever hot-melt equipment is re-assembled. All new O-rings should be lubricated with o-ring lube (PN 001V078).
- TAPERED PIPE THREADS are found on air line fittings used with the pump air supply (if applicable) and on the outlet filter manifold. Apply thread sealant (PN N02892) whenever tapered pipe threaded parts are re-assembled.
- SOME FITTINGS used for adhesive on the Melter have straight threads and o-ring seals. Use of thread sealant is not necessary with these parts, but the o-ring seals should be clean and lubricated. Tighten straight-threaded parts and fittings until their shoulders are firmly seated against the pump body (or other surface). Excessive torque may damage straight-threaded parts and the use of power wrenches is not recommended.
- HOT-MELT RESIDUE should be cleaned from parts before they are re-assembled, particularly from threaded parts. As a precaution against adhesive residue preventing proper re-assembly, threaded parts should always be re-tightened at operating temperature.

Chapter 9

Available Options & Accessories

9.1 Pressure Gauge Assembly PN 101175

An optional analog pressure gauge can be mounted on the outlet filter manifold. Reading the adhesive pressure at the manifold, rather than in-line on a hose, allows for more precise monitoring of system pressure. It is also useful for troubleshooting and maintenance.

The gauge is installed at one of the adhesive ports on the manifold. Fittings and adapter are included in the assembly.

9.2 Pre-PSI & Post-PSI Transducers PN 811475; Transducer Assembly PN 814521

A pressure transducer is an electronic probe that allows the melted adhesive's pressure to be processed by the Melter's control system. They are used to monitor system operating pressures and their limits. The Pre-PSI transducer measures adhesive pressure in the filter manifold *before* the filter basket. The Post-PSI transducer measures the pressure *after* the filter basket. By comparing the two readings, the operator can determine if the filter basket is clogged.

9.3 Drop-in Grids PN 104802

The drop-in grid is an extra heated grid(s) which is installed near the bottom of the Melter's hopper. The additional grid(s) allows faster melting of adhesive for applications requiring higher melt rates and higher volumes of adhesive. When installed, the drop-in grid becomes an auxiliary temperature zone on the controller.

9.4 High-Temperature Heater Groups

More accurate temperature control may be gained by using a High-Temp Heater Group in the filter manifold/ pressure relief block. A heater and sensor are contained inside the block and become their own temperature zone on the controller. Six groups are available depending on the number of filter manifolds on the Melter.

9.5 Filter Options

Part Number	Description
814007	40-Mesh Easy-Spin Filter
814008	80-Mesh Easy-Spin Filter
814009 *	100-Mesh Easy-Spin Filter
814010	150-Mesh Easy-Spin Filter

* standard

9.6 Level Control Options

Level control devices inform the operator, via a message on the Controller, that the hopper's adhesive level is low. They may also be wired to stop production, turn on an alarm light or signal, or signal a PLC.

Level Control Kit PN	Description
810237	Single-Point Level Control Kit, 5m, (for all M-series) - incl. PN 810235 Level probe M22 5m
823784	Continuous Level Control Kit 500MM, RECHNER (for M35 and M70) - incl. PN 823783 Level probe 500mm PEEK 4-20A output
824110	Continuous Level Control Kit 1000mm, RECHNER (for M140 and M210) - incl. PN 824109 Level probe 1000mm PEEK 4-20A output

9.7 Pumps and Accessories

For higher tolerances and precision, several gear pumps are available for the Dynamelt. Gear pumps give better service for continuous applications or applications which require more control over the volume of adhesive pumped. See Appendix "Pumps" for further details.

9.8 Gear Pump Repair Kit, PN 103151

The kit contains the following items needed to repair all Dynatec manufactures gear pumps from 0.15cc to 20cc. See list of pumps supported by this kit.

Gear Pump Repair Kit PN 103151 BOM:

PN	Description	Qty
018X031	Bearing ball 1/8 dia.	6
069X061	Shaft seal, Dynatec pump	1
069X064	O-ring 041	3
069X225	O-ring 042	1
078F017	Retaining ring, ext., .50D	4
078I001	Key Woodruff #404	1
N00188	O-ring 022	1
N00198	O-ring 113	2

List of gear pumps supported by the kit 103151:

PN	Description	Code
111253	0.15cc single	GGG
111254	0.15cc dual	GGD
109908	0.55cc single	GDS
109909	0.55cc dual	GDD
100860	1.5cc single	GAS
100863	1.5cc dual	GAD
100861	3.2cc single	GBS
100864	3.2cc dual	GBD
100862	4.5cc single	GCS
109690	10cc single	GES
109694	20cc single	GFS

9.9 Two Output, Two Filter Manifold PN 102049

The two output, two filter manifold is required with a dual gear pump. It allows the operator to adjust the two pressure relief valves independently of each other.

9.10 Return (re-circulating) Hoses

Available on all models. Use of return hoses allows higher adhesive pressures from the head to the substrate because the head is "overfed" adhesive. The overflow adhesive is re-circulated to the hopper.

9.11 Dual Hopper

Available on DM M140 and M210. The adhesive hopper on the dual hopper models is divided into two separate chambers to allow the application of two different adhesives simultaneously. Each chamber is an independent temperature zone, allowing them to operate at different adhesive temperatures.

9.12 High Flow Melters

These Melters are available as DM140 or M210 units for applications requiring a pump rate up to 2,625 cc/min per pump. The high flow models are equipped with high flow grid groups, including high flow hoppers, filter and shutoff assemblies, filter manifolds and filter baskets.

9.13 DynaControl V6 Controller Options

9.13.1 System Status Lights PN 116848

Remote monitoring of system status is made easier with this tri-color light. The stack light is mounted on a 6"x 6" box, which is itself mounted on a stand with a 10' cable. Wired into the controller, the lights illuminate to indicate "Power On", "Ready" and "Alarm". An audible signal accompanies the "Alarm" light. The alarm may be wired to indicate either high/low temperature, low adhesive level or open/short sensor.

9.13.2 V6 Communications Adapters

V6 EtherNet IP Kit PN 118925
V6 Profibus Kit PN 118926
V6 EtherCAT Kit PN 118927
V6 ProfiNet Kit PN 121436

The V6 communications bus module adapts the Melter to full remote operation so that all system parameters can be transmitted and received.

9.13.3 Multi-Melter-System w. Central HMI Kit: PN 118945

This option allows several Melters (a maximum of ten) to be controlled by one V6 HMI touch panel, mounted in one of the units. Each Melter to be controlled is installed with a kit, which contains a cable, a RS232 converter and hardware.

9.14 Signal Isolator PN 117143

A signal isolator conditions a parent machine's production line's DC speed voltage or current reference to allow the Melter's gear pump to track the application's line speed. It accepts 0-10V, 0-5V, 4-20mA inputs and outputs a proportional 0-10V signal to DynaControl's electronics.

9.15 Ramp Compensation Kits

Six-Solenoid Kit for M210, PN 821642

The HMI's ramp compensation option allows the user to reduce the excess adhesive that can occur during parent machine ramp-up and ramp-down. The system utilizes pneumatic pressure relief valves (PN 116486, ordered separately) to control each pump stream (output).

Pneumatic Pressure Relief Valve Assembly PN 116486

The pneumatic pressure relief valve provides a method to drop adhesive pressure to zero by turning off air supply to the Melter.

9.16 Repair Kit PN 109982, for Adjustable Pressure Relief Valve 101840

Contains the following three items needed to repair the PN 101840 Adjustable Pressure Relief Valve:

1x N00179 O-ring 012,
1x N01601 O-ring 908 and
1x N05733 Backup Ring, 012.

9.17 Harting Connector PN 815146

A quick-disconnection interface that allows an electrical connection between the hot melt unit and the customer's machinery.

9.18 Recommended Service Parts List, M210

Category	Part Number	Description	Quantity
Electrical:	112568	Fuse 10AF, (on power module)	20
	119975	Fuse 12AF, (on power module)	5
	804534	Fuse 30A, LP-CC (terminal rail) (240V units only)	23
	036B103	Temperature sensor RTD, PT100, Ø 0.1875x1.25" (Ø 0.48x3.18cm), leads 24" (61cm)	2
	N07958	Temperature sensor RTD, PT100, Ø 0.1875x1.25" (Ø 0.48x3.18cm), leads 48" (122cm)	1
	104166	Switch Assembly, Over Temperature Thermostat, NC, 450°F	1
	114232	Solid State Relay, Dual, 40A, 24V, 240VAC	12
	821247	Relay, DPDT, 24VDC	2
	119156	Power Supply, 24 VDC 6A	1
	036A170	Heater 500W, 240V, 5/8x5 (for single filter manifold Melter)	1
	036A079	Heater 1000W, 240V, 5/8x10 (for 2 filter manifolds Melter)	1
	102149	Heater 1500W, 240V, 5/8x15 (for 3 filter manifolds Melter)	1
	036A077	Heater 2000W,240V, 5/8x20 (for 4 filter manifolds Melter)	1
	822441	Motor Speed Control Kit, 1HP, Yaskawa (incl. motor control PN 815223)	1
	115734	V6-Base Module Assy	1
	115735	V6-Temp Module Assy	1
	116823	V6-Motor Module Assy	1
	118584	V6-SSR Adapt PCB Assy	1
	823306	V6-Power PCB Assy	1
	118125	V6-Communication Assy. (EtherNet option)	1
O-rings:	N00181	O-ring 014 (outlet filter/ manifold)	12+14 per manifold
	A69X133	O-ring 124 (outlet filter/ manifold)	2 per manifold
	N00187	O-ring 020 (outlet filter/ manifold)	2 per manifold
	N00183	O-ring 016 (outlet filter/ manifold)	4 per manifold
	N00185	O-ring 018 (outlet filter/ manifold)	4 per manifold
	812816	O-ring 127 (outlet filter/ manifold)	2 per manifold
	N00192	O-ring 032	6
	807729	Pump Shaft Seal (Zenith/ TSHA pump models)	2 per pump
	069X061	Pump Shaft Seal (optional ITW Dynatec pumps)	2 per pump
	069X289	Pump Shaft Seal (Hi Flow pump models)	2 per pump
	069X064	O-ring 041 (optional pump block off assembly)	1
	See item BOM	Pump Adapter O-rings	1 of each per pump
	Filters:	814007	Easy-Spin Filter, 40 mesh (optional)
814008		Easy-Spin Filter, 80 mesh (optional)	2 per manifold
814009		Easy-Spin Filter, 100 mesh (standard)	2 per manifold
814010		Easy-Spin Filter, 150 mesh (optional)	2 per manifold
105968		Filter and Shutoff Assembly, right-hand	1
105969		Filter and Shutoff Assy, left-hand, long	1

Others:	108689	Silicone Lubricant, O-ring, Dow 112, 0.25	1
	L15653	Kit, Flushing Fluid, 1 gallon	1
	001U002	Hi-Temp Lubricant, silicone grease DOW112, tube	1
	808217	Adjustable Relief Valve, 0-750psi (0-50bar)	1
	814018	Filter Nut, ES	1
	102717	Check Valve	1
	116486	Pneumatic Pressure Relief Valve (option)	1
	030A049	Solenoid, 3way, 1/8 NPT (option)	1

Chapter 10

Component Illustrations and Bill of Materials



WARNING

All parts must be periodically inspected and replaced if worn or broken. Failure to do this can affect equipment's operation and can result in personal injury.

This chapter contains the component illustrations (exploded-view drawings) for each assembly of the Melter. These drawings are useful for finding part numbers as well as for use when maintaining or repairing the equipment.

Note: Most common screws, nuts and washers called out in the manual are not for sale and they can be obtained locally at your hardware Store. Specialty fasteners are available by contacting ITW Dynatec's Customer Service.

10.1 Base Assemblies

10.1.1 Base Assembly, M210 Dual Hopper, PN 106054

Part Number	Description	Quantity
106042 *	Grid group, M210, dual hopper	1
106047 *	Cabinet & covers assembly, M210	1
106403	Wire asy, high-temp thermostat	4
106404	Wire asy, heater plate	4
108534	Instructions, pump & zones, MV5	0
118124	Tag, Warning, verify volt	1

* see separate drawing and/or BOM.

10.1.2 Base Assembly, M210 Single Hopper, PN 106055

Part Number	Description	Quantity
106043 *	Grid group, M210, single hopper	1
106047 *	Cabinet & covers assembly, M210	1
106403	Wire asy, high-temp thermostat	2
106404	Wire asy, heater plate	4
108534	Instructions, pump & zones, MV5	0
118124	Tag, Warning, verify volt	1

* see separate drawing and/or BOM.

10.1.3 Base Assembly, M210 High-Flow Hopper, PN 106697

Part Number	Description	Quantity
106695	Grid group, M210, high-flow	1
003E023	Cover	3
036B015	Thermostat N.O. Ø1/2	3
036B103	Temperature sensor RTD, PT100, Ø 0.1875x1.25" (Ø 0.48x3.18cm), leads 24" (61cm)	5
048J014	Fitting 3/4 45°	2
048J048	Conduit 1/4ID (UIT302)	4
048J049	Fitting, 1/4" conduit, 9/16-18	2
048J064	Bushing, 3/4* insulating	4
048J088	Straight conduit fitting 3/4"	2
101156	Screw M6x1x20	24
101625	Fitting, socket plug, G1/4	2
102411	Cap, hi temp, .60 IDx1.5L	6
102446	Screw M4-0.70x10	6
103538	Screw M4-0,7x6mm	8
104166	Switch asy, over temp	3
104696	Plate, grid	3
104802	Grid	3
105099	Screw M8x1.25x25	12
105149	Plate, grid block off	3
105881	Heater plate, 5000W, 240V	3
105885	Junction box	2
105968 *	Filter and Shutoff assembly, right hand	1
105969 *	Filter and Shutoff assembly, left-hand, long	1
105999	Bracket	6

106000	Spacer, heater plate	1
106001	Cover, junction box	2
106156	Screw M4x6	13
106174	Adapter, sensor, grid	3
106235	Washer, flat, M8	12
106237	Lock washer, ext. tooth, M8	12
106621	Hopper asy, M210, high-flow	1
106719	Junction box, M210	1
107389	Screw M4x8, with washer	8
107441	Terminal rail asy	1
107645	Conduit,5/16,SST,12"long	2
107646	Conduit,5/16,SST,28"long	2
107751	Fitting,5/16" cond,9/16-18	11
108564	Block for heater control	1
108565	Cover for heater block	1
108567	Wire asy, hi temp t'stat	2
108706	Wire asy, ground, hopper	1
108779	Kit, hopper insulation M210, single hopper	1
108813	Terminal rail asy, M210	1
108831	Conduit,3/4"sealtite,36"	2
108832	Wire asy, middle heater plate, M210	2
109235	Conduit,5/16,sst,32"long	1
805728	Screw M8x1.25x55	2
825199	Schematics, M210 high-flow	0
L00006	Insulation / spacer .25 THK	18
N00181	O-ring 014	12
N00192	O-ring 032	6
N00686	Washer .250	72
N00697	Washer, spring lock, 1/4	72
N06883	Nut, hex jam, 9/16-18	11
N07370	Screw M6x1x30	12
N07416	Screw M8 x 35	12
106047 *	Cabinet & covers assembly, M210	1
108534	Instructions, pump & zones, MV5	0
118124	Tag, Warning, verify volt	1

* see separate drawing and/or BOM.

10.2 Cabinet & covers assembly, M210, PN 106047

Item No.	Part Number	Description	Quantity
1	101843	Handle	4
2	105981	Panel	1
3	105887	Access cover	2
4	105980	Rear cover	1
5	106897	Wire box	6
6	105974	Base plate	1
7	105982	Top panel	1
8	105977	Heat barrier	1
9	820416	Manifold cover, ES, new style	3
	108128	Manifold Cover, Hi-Flow only	3
10	802679	Panel box	1
11	802102	Mounting bracket	1
12	106110	Hex nut M5	1
13	009E006	Rigid caster	2
14	009E009	Swivel caster	2
15	101074	Receptacle	Up to 24
16	103866	Bracket	1
17	108296	Screw M8x16mm HHC	24
18		Star washer M8	16
19	078C008	Flat washer 5/16	16
20	106111	Screw M4x12 BHC	48
21	101304	Blank plate, dual	Up to 11
22	104279	Blank plate, single	0 or 6
23	105111	Hex nut M3	Up to 24
24	107392	Nut M8	4
25	107390	Nut M6	4
26	108295	Screw M8x12mm HHC	3
27	106048	Lid assembly (items 28-43)	2-3
28	N01788	Screw 10-32x0.375 BHC	4
29	N04302	Lock washer with ext. tooth	4
30	809489	Fan filter 5" (not shown)	1
31	815007	Exhaust grill kit	1
32	107390	Hex nut with washer M6	2
33	116939	Hinge, left	2
34	116940	Hinge, right	2
35	106198	Lock washer M4	4
36	105937	Screw M4x2mm SHC	4
37	105101	Screw M6x16mm HHC	2
38	-	-	-
39	106770	Heat deflector	1
40	106771	Collar, hopper	1
41	101842	Handle, hopper lid	1
42	106769	Lid hopper	1
43	806400	Lid (with level control mounted)	1
44	107890	Ground screw filter	3
45	101156	Screw M6x20mm SHC	6
46	107390	Nut M6	10

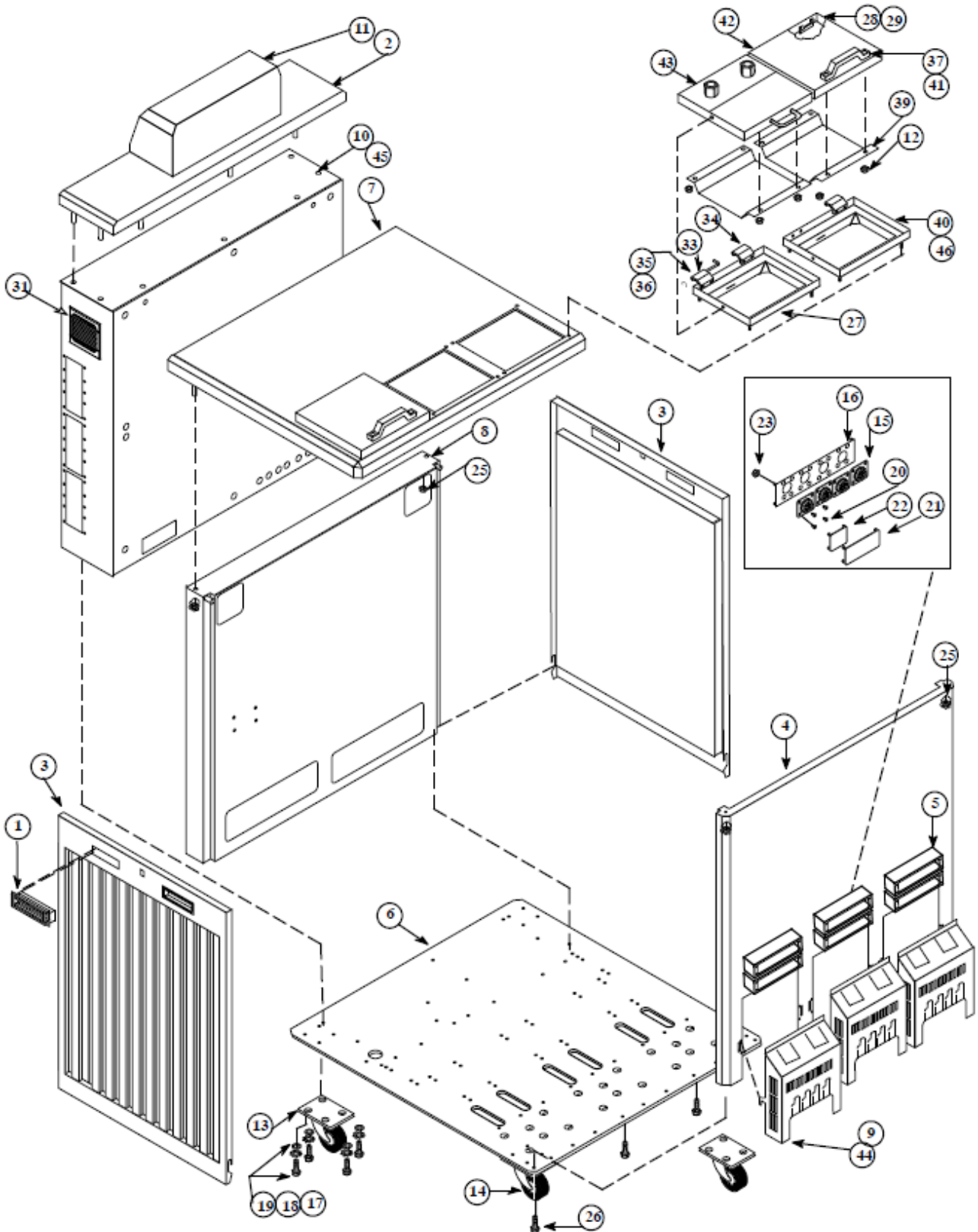

Illustration: Cabinet Assembly M210, PN 106047

10.3 Grid Assemblies

10.3.1 Grid Group, Dual Hopper, PN 106042

Item No.	Part Number	Description	Qty
1	078D022	Jam nut 9/16-18	12
2	102446	Screw M4-0,70x10mm	10
3	105881	Heater plate 5000W 240V	3
4	107602	Screw M8-1,25x40mm	36
5	104802	Grid	3
6	814550	Screw M8-1,25x35mm	12
7	106156	Screw M4x6mm	16
8	108297	Screw M8-1,25x20mm	30
9	105968 *	Filter and Shutoff assembly, right-hand	1
10	105097	Screw M6x30mm	2
11	104166	Switch AS, over temp	3
12	105885	Junction-Box	2
13	105099	Screw M8x25mm	2
14	107441	Terminal rail asy, LG	1
15	106001	Cover	2
16	107751	Fitting, 5/16" conduit, 9/16-18	12
17	102411	Cap, high-temp	6
18	105999	Bracket	6
19	105135	Insulating spacer .75	18
20	N00192	O-ring -032	6
21	N00181	O-ring -014	24
22	106174	Adapter	3
23	104696	Plate	3
24	N07958	Temperature sensor PT100 .187x1.25	6
25	003E023	Cover	3
26	105149	Plate	3
27	072X093	Level seal plug 1/2 NPT	4
28	069X274	Seal, pump to hopper	6
29	036B015	Thermostat NO 1/2 dia.	3
30	107389	Screw M4x8mm with washer	16
31	048J014	Fitting 3/4, 45°	2
32	048J048	Conduit 1/4 ID	4
33	048J049	Fitting 1/4", conduit 9/16-18	2
34	048J064	Bushing 3/4" insulating	4
35	048J088	Straight conduit fitting 3/4"	2
36	107645	Conduit 5/16, 12" long	2
37	107646	Conduit 5/16, 28" long	2
38	108567	Wire asy, high-temp thermostat	2
39	108706	Wire asy, ground, hopper	1
40	108831	Conduit 3/4" sealtite, 36"	2
41	108832	Wire asy, mid heater plate	2
42	109235	Conduit 5/16, 32" long	1
43	105890	Hopper asy, single, DMM140	1
44	103749	Nut, filter/plug	2
45	825424	Box	1
46	825018	Cover, mid sensor/thermostat	1
48	105969 *	Filter and Shutoff assembly, left-hand, long	1
49	048J015	Connector 1/2 sealtite	1
52	108813	Terminal rail asy	1
53	105974	Base plate	1
54	105884	Hopper asy, dual, DMM140,210	1
55	108784	Hopper insulating kit	1
56	811278	Grid support	3
57	101625	Plug 1/4 BSPP	4

* see separate drawing/ BOM.

THIS DRAWING IS THE PROPERTY OF EVIDENTEC.
DO NOT REPRODUCE OR REFERENCE TO
OTHERS WITHOUT EXPRESS WRITTEN
CONSENT OF EVIDENTEC.

DWG. NO. 106042

REV.	REV.	DESCRIPTION	DATE	BY	APPROVED
125379	Q	ORIGINAL RELEASE	03.05	ADC	
05389	R	ADDED ITEM 56	10.18.05	ADCLF	
10217	S	WAS N07429	09.10.10	AMF	
11016	T	ADDED ITEM 57	2.3.11	BB	
17037	U	DEL N0683 CHNG TO 078D022 DEL 10664 10665 10000 90305 100715 ADD 922016 4 825424 048J015 CHNGD 107632 QTY TO 36	9.08.17	LF	

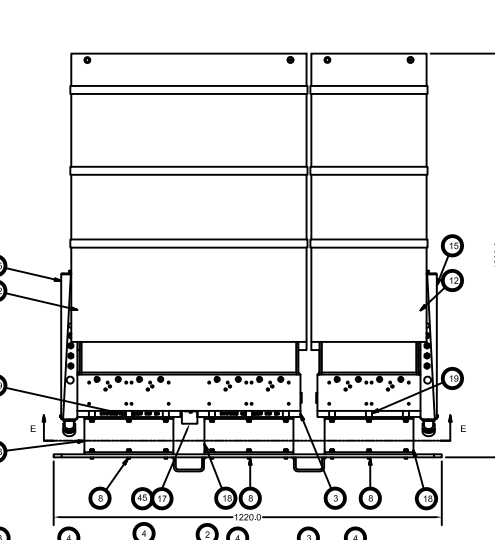
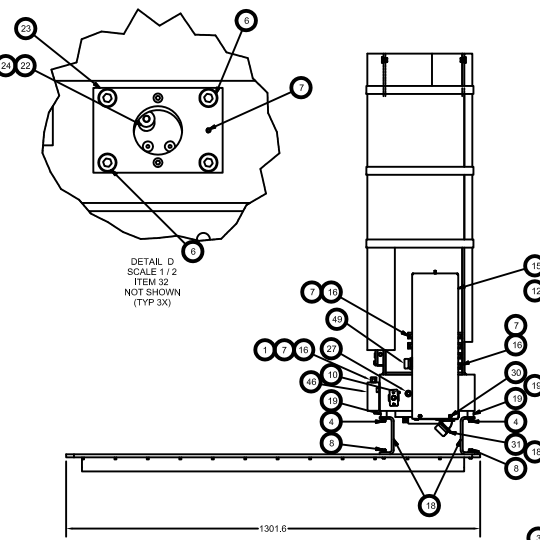
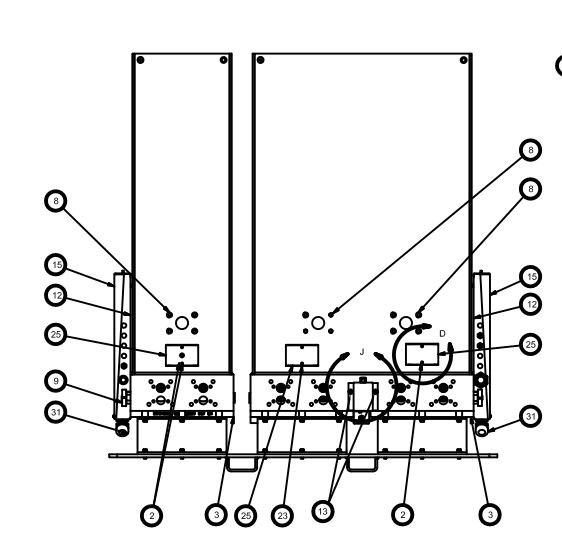
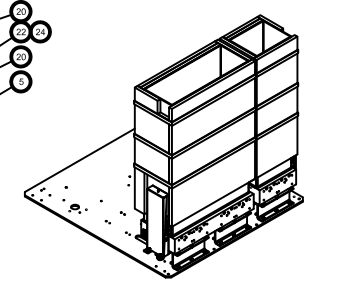
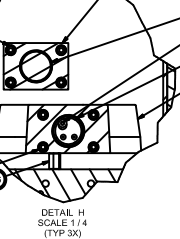
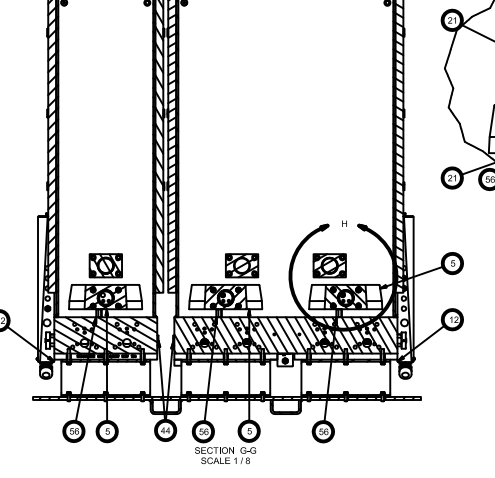
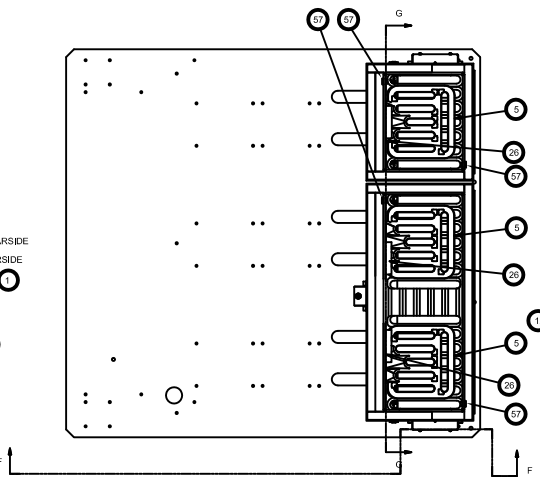
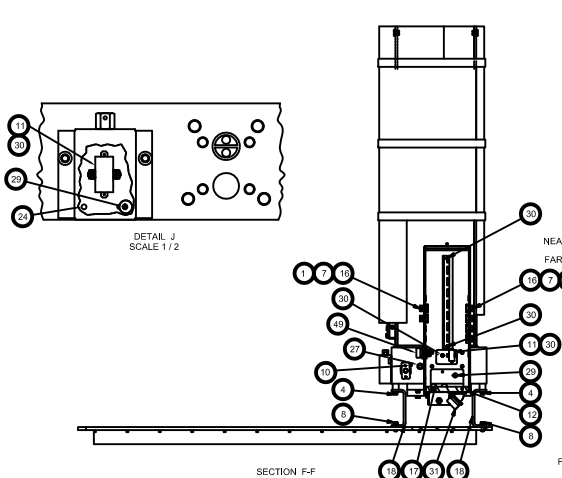

57	101825	4	EA	PLUG, 1/4 BSSP
56	811275	3	EA	GRID SUPPORT DMM
55	108784	1	EA	KIT, HPR INSL, M210, DUAL
54	105884	1	EA	HPR AS, DUAL, DMM210, 210
53	106974	1	EA	PLATE, BASE, DMM210
52	108813	1	EA	TERM RAIL, ASY, M210
51				
50				
49	048J015	1	EA	1/2 IN. SEALTITE CONNECTOR, ST.
48	105969	1	EA	FLTR/SHTOFF AS, SING, DMM
47				
46	825016	1	EA	CVR MID SNSR/TSTAT, DMM210
45	825424	1	EA	BOX, JCT, DMM210, CENTER HTR
44	103749	2	EA	NUT, FLTR/PLUG, 50, MD
43	106890	1	EA	HOP ASY, SING, DMM210
42	106235	1	EA	CONDUIT, 5/16 SST, 3/2" LONG
41	108832	2	EA	WIRE ASY, MID HTR, T/M210
40	108831	2	EA	CONDUIT, 3/4" SEALTITE, 36"
39	108706	1	EA	WIRE ASY, GND, HOPPER, DMM
38	108567	2	EA	WIRE ASY, HI TEMP, TSTAT
37	107646	2	EA	CONDUIT, 5/16 SST, 28" LONG
36	107645	2	EA	CONDUIT, 5/16 SST, 27" LONG
35	048J068	2	EA	3/4" STRGHT CONDUIT FITT
34	048J064	4	EA	BUSHING, 3/4" INSULATING
33	048J049	2	EA	FTG, 1/4" COND, 9/16-18
32	048J048	4	EA	FT, T4ID CONDUIT (UIT302)
31	048J014	2	EA	3/4 45 DEG. FITTING
30	107359	16	EA	SCR, PHP, M4X8 WWSHR
29	0368015	3	EA	TSTAT, N.O., 1/2 DIA.
28	069X274	6	EA	SEAL, DUAL PUMP TO PROG MEL
27	072X093	4	EA	1/2 NPT LEVEL SEAL, PLUG
26	105149	3	EA	PLATE, GRND BLOCK OFF, MET
25	073E023	3	EA	COVER
24	N07958	6	EA	SNSR, RTD, PT100, .187X1.25
23	104696	3	EA	PLT, BKG, GRID, MET
22	106174	3	EA	ADPTR, SNSR, GRID
21	N00181	24	EA	O-RING, .014, 70 DUR, VITO
20	N00159	6	EA	O-RING, .032, 70 DUR, VITON
19	105135	18	EA	INSUL, SPACER, 75
18	105999	6	EA	BRKT, HPR, SUPT, DMM210/140
17	102411	6	EA	CAP, HI TEMP, .60 IDX1.5L
16	107751	12	EA	FTG, 5/16" COND, 9/16-18
15	106901	1	EA	CVR, J-BOX, DMM
14	107441	1	EA	TERM RAIL, ASY, LG, DMM
13	105099	2	EA	SCR, SKT, HD, CAP, M8X25
12	105885	2	EA	J-BOX, DMM
11	104166	3	EA	SW AS, OT, DM
10	105997	2	EA	SHSS, M4X3, BLK, OX
9	105968	1	EA	FLTR/SHTOFF AS, RH, DMM
8	108297	30	EA	SCR, HH, SER, FL, M8-1.25X20
7	106156	16	EA	SHSS, M4X6, BLK, OX
6	814550	12	EA	SCR, SKT, HD, M8-1.25 X 35 ZP
5	104802	3	EA	GRID, MACH, RNF, DM
4	107692	36	EA	SCR, HH, SER, FL, M8-1.25X40
3	105851	3	EA	HTR, PLT, 5000W, 240V, DN-M
2	102446	10	EA	SCR, SHC, M4-0.70X10
1	078D022	12	EA	9/16-18, JAM NUT
ITEM	PART NUMBER	QTY	UOM	DESCRIPTION



NOTES:
1. ITEMS 32 THROUGH 42 NOT SHOWN.

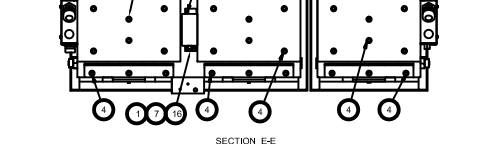

DESIGN APPROVED BY: SIGNED AND DATED: DATE: 04.08.05	FOR MACHINING STANDARDS AND SYMBOLS, SEE EVIDENTEC DRAWING PRACTICES (DPPC, 4000)	Parts List	UOM
DESIGNED BY: M SERIES	APPROVED BY: A. COONS	DATE: 04.08.05	EA
CHECKED BY: VARIES	DATE: 04.08.05	GRID GROUP DMM210, DUAL	STATUS P
DO NOT SCALE DRAWING	GRID GRP, DMM210, DUAL	DWG. NO. 106042	SOURCE C
		DATE PLOTTED: 04.08.05	REV. U
		SCALE: 1:1	SHEET NO. 1 OF 1

10.3.2 Grid Group, Single Hopper, PN 106043

Item No.	Part Number	Description	Qty
1	078D022	Jam nut 9/16-18	12
2	102446	Screw M4-0,70x10mm	8
3	105881	Heater plate 5000W 240V	3
4	803945	Screw M8-1,25x60mm	6
5	107602	Screw M8-1,25x40mm	36
6	104802	Grid	3
7	814550	Screw M8-1,25x35mm	12
8	106156	Screw M4x6mm	16
9	108297	Screw M8-1,25x20mm	30
10	105968 *	Filter and shutoff assembly, right-hand	1
11	105969 *	Filter and Shutoff assembly, left-hand, long	1
12	105097	Screw M6x30mm	2
13	104166	Switch AS, over-temp	3
14	105099	Screw M8x25mm	2
15	105885	Junction-Box	2
16	048J015	Connector 1/2in sealtite	1
17	107441	Terminal rail asy, LG	1
18	108813	Terminal rail asy	1
19	105974	Base plate	Ref.
20	106001	Cover	2
21	107751	Fitting, 5/16" conduit, 9/16-18	12
22	825424	Box	1
24	102411	Cap, high-temp	6
25	105999	Bracket	6
26	105135	Insulating spacer .75	18
27	N00192	O-ring -32	6
28	N00181	O-ring -14	24
29	106174	Adapter	3
30	104696	Plate	3
31	N07958	Temperature sensor PT100 .187x1.25	6
32	003E023	Cover	3
33	105149	Plate	3
34	072X093	Level seal plug 1/2 NPT	2
35	069X274	Seal, pump to hopper	6
36	825018	Cover, mid sensor/thermostat	1
37	036B015	Thermostat NO 1/2 dia.	3
38	107389	Screw M4x8mm with washer	16
40	048J014	Fitting 3/4, 45°	2
41	048J048	Conduit 1/4 ID	4
42	048J049	Fitting 1/4", conduit 9/16-18	2
43	048J064	Bushing 3/4" insulating	4
44	048J088	Straight conduit fitting 3/4"	2
45	107645	Conduit 5/16, 12" long	2
46	107646	Conduit 5/16, 28" long	2
47	108567	Wire asy, high-temp thermostat	2
48	108706	Wire asy, ground, hopper	1
49	108831	Conduit 3/4" sealtite, 36"	2
50	108832	Wire asy, mid heater plate	2
51	109235	Conduit 5/16, 32" long	1
52	106617	Hopper asy, single, DMM210	1
	106621	Hopper asy, single, DMM210, high-flow	1
53	108779	Hopper insulating kit	1
54	811278	Grid support	3
55	101625	Plug 1/4 BSPP	2

* see separate drawing/ BOM.

REV.	REV.	DESCRIPTION	DATE	BY	APPROVED
Q		ORIGINAL RELEASE	12.15.04	ADC	
05389	R	ADDED ITEM 54	10.18.05	ADC	LF
10217	S	WAS N07429	09.10.10	KMF	
11016	T	ADDED ITEM 55	2.3.11	BB	
17037	U	DEL. N0883 CHNG TO 078022; DEL. 10854 10885; 10600; 803845; 106719; ADD 825018 & 825424; 048J015; CHNGD; 107832 QTY TO 36	08.28.17	LF	

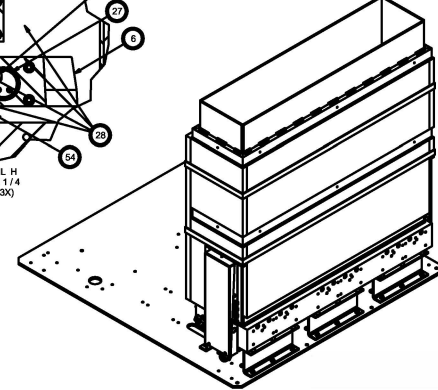
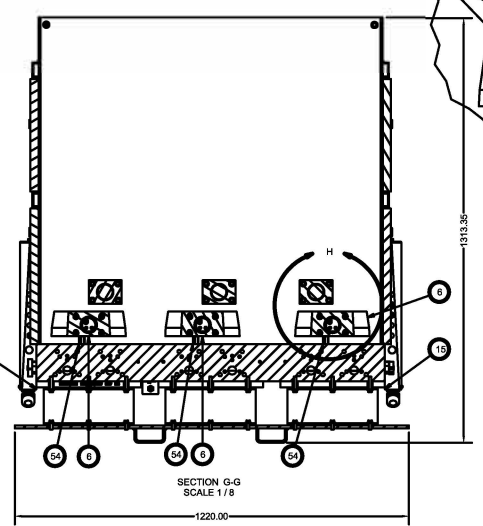
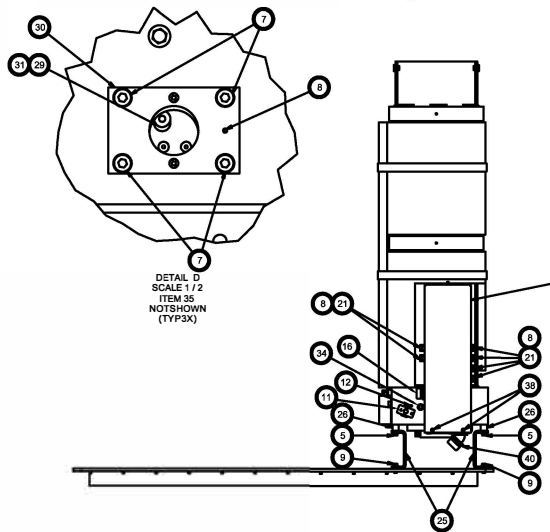
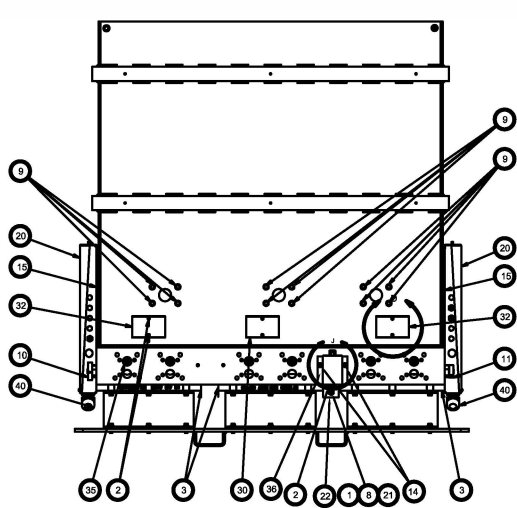
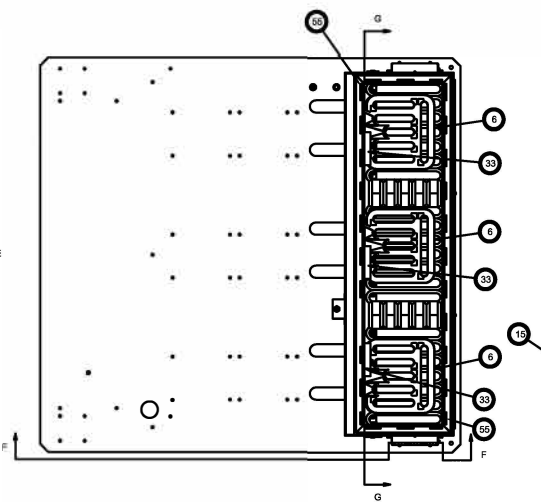
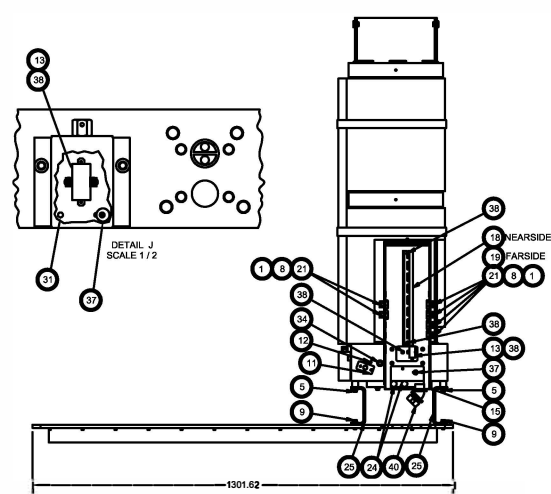

ITEM	PART NUMBER	QTY	UM	DESCRIPTION
55	101625	2	EA	PLUG, 1/4 BSPP
54	811278	3	EA	GRID SUPPORT DMM
53	100779	1	EA	KIT HPR INSL M210 SINGL
52	106117	1	EA	HOP AS SIN DMM210
51	109235	1	EA	CONDUIT, 5/16 SST, 32' LONG
50	108832	2	EA	WIRE ASY, MID HTR PLT, M210
49	108831	2	EA	CONDUIT, 3/4" SEAL TITE, 36"
48	108706	1	EA	WIRE ASY, GND, HOPPER, DMM
47	108867	2	EA	WIRE ASY, HI TEMP, TS1AT
46	107846	2	EA	CONDUIT, 5/16 SST, 28' LONG
45	107845	2	EA	CONDUIT, 5/16 SST, 12' LONG
44	048J088	2	EA	3/4" STRIGHT CONDUIT FITT
43	048J064	4	EA	BUSHING, 3/4" INSULATING
42	048J048	2	EA	FTG, 1/4" COND, 8/16-18
41	048J049	4	EA	FTG, 1/4" COND, 1/16-32
40	048J014	2	EA	3/4-45 DEG. FITTING
39				
38	107389	16	EA	SCR, PHP, M4XBW/WSHR
37	036B015	3	EA	TS1AT, N.O. 1/2 DIA.
36	025076	1	EA	CVR, MID SNRS/STAT, DMM210
35	088X274	6	EA	SEAL, DUAL PUMP, TO PROG MEL
34	072X093	2	EA	1/2 NPT LEVEL SEAL PLUG
33	105149	3	EA	PLATE, GRID BLOCKOFF, MET
32	003E023	3	EA	COVER
31	N07958	6	EA	SNRS, RTO, PT100, 18'X1.25
30	104866	3	EA	PLT, BKG, GRID, MET
29	106174	3	EA	ADPTR, SNRS, GRID
28	N00181	24	EA	O-RING, .014, 70 DUR VITO
27	N00192	6	EA	O-RING, .032, 7SDUR, VITON
26	105135	18	EA	INSUL, SPACER, 75
25	105999	6	EA	BRKT, HPR, SUP, DMM/0140V
24	102411	6	EA	CAP, H8 TEMP, 60 DX1.5L
23				
22	825424	1	EA	BOX, JCT, DMM210, CENTER HTR
21	107751	12	EA	FTG, 5/16" COND, 8/16-18
20	108001	2	EA	CVR, J-BOX, DMM
19	105974	REF	EA	PLATE, BASE, DMM210
18	108813	1	EA	TERM, RAIL, ASY, M210
17	107441	1	EA	TERM, RAIL, ASY, LG, DMM
16	048J015	1	EA	1/2 IN. SEAL TITE CONNECTOR, ST.
15	105885	2	EA	J-BOX, DMM
14	105989	2	EA	SCR, M8X25, ALLEN
13	104459	3	EA	SVR, AS, OT DM
12	105087	2	EA	SHSS, M8X30, BLK, DX
11	105969	1	EA	FLTR, SH/OFF, AS, SING, DMM
10	105968	1	EA	FLTR, SH/OFF, AS, RH, DMM
9	108297	30	EA	SCR, HH, SER, FL, M8-1.25X20
8	106196	16	EA	SHSS, M4X6, BLK, DX
7	8144550	12	EA	SCR, SHT, HD, M8-1.25 X 35 ZP
6	104802	3	EA	GRID, MACH, KNF, DM
5	107602	36	EA	SCR, HH, SER, FL, M8-1.25X40
4	803845	6	EA	SCR, M8-1.25X60, HHCS, 8.8
3	105881	3	EA	HTR, PLT, 5000W, 240V, DM-M
2	102446	8	EA	SCR, SHC, M4-D, 70X10
1	078022	12	EA	8/16-18 JAM NUT

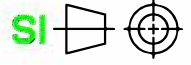

DESIGNER: A. COONS CHECKED: A. COONS DATE: 12.15.04	PDR: MACHINING STANDARDS TYPEDRAWING: SPECIAL AGREED	metric SI	DRAWN: A. COONS DATE: 12.15.04	ITEM: EA STATUS: P REVISION: C
M SERIES VARIES	GRID GROUP DMM210, SINGLE		106043	GROUP: U 1 OF 1

10.3.3 Grid Group, Single Hopper, High-Temp Version, PN 804947

Item No.	Part Number	Description	Qty
1	078D022	Jam nut 9/16-18	1
2	102446	Screw M4-0,70x10mm	10
3	105881	Heater plate 5000W 240V	3
4	803945	Screw M8-1,25x60mm	6
5	107602	Screw M8-1,25x40mm	30
6	104802	Grid	3
7	N07429	Screw M8-1,25x30mm	12
8	106156	Screw M4x6mm	16
9	108297	Screw M8-1,25x20mm	30
10	804465 *	Filter and Shutoff assembly, right-hand, high-temp	1
11	804948 *	Filter and Shutoff assembly, left-hand, long, high-temp	1
12	105097	Screw M6x30mm	2
13	036B013	Thermostat NC 1/2 dia.	3
14	105110	Screw M8x55mm	2
15	105885	Junction-Box	2
16	N06883	Nut, hex jam, 9/16-18	11
17	107441	Terminal rail asy, LG	1
18	108813	Terminal rail asy	1
19	105974	Base plate	Ref.
20	106001	Cover	2
21	107751	Fitting, 5/16" conduit, 9/16-18	12
22	106719	Box	1
23	106000	Spacer	1
24	102411	Cap, high-temp	6
25	105999	Bracket	6
26	105135	Insulating spacer .75	18
27	069X285	O-ring -32	6
28	N07081	O-ring -14	24
29	106174	Adapter	3
30	104696	Plate	3
31	036B103	Temperature sensor PT100 .187x1.25	6
32	003E023	Cover	3
33	105149	Plate	3
34	072X093	Level seal plug 1/2 NPT	2
35	803637	Seal, pump to hopper	6
36	108564	Block, heater control	1
37	036B015	Thermostat NO 1/2 dia.	3
38	107389	Screw M4x8mm with washer	14
39	108565	Cover, heater control block	1
40	048J014	Fitting 3/4, 45°	2
41	048J048	Conduit 1/4 ID	4
42	048J049	Fitting 1/4", conduit 9/16-18	2
43	048J064	Bushing 3/4" insulating	4
44	048J088	Straight conduit fitting 3/4"	2
45	107645	Conduit 5/16, 12" long	2
46	107646	Conduit 5/16, 28" long	2
47	108567	Wire asy, high-temp thermostat	2
48	108706	Wire asy, ground, hopper	1
49	108831	Conduit 3/4" sealtite, 36"	2
50	108832	Wire asy, mid heater plate	2
51	109235	Conduit 5/16, 32" long	1
52	804930	Hopper asy, single, high-temp	1
53	108779	Hopper insulating kit	1
54	811278	Grid support	3
55	101625	Plug 1/4 BSPP	2

* see separate drawing/ BOM.

THIS DRAWING IS THE PROPERTY OF IRI/PINWEL.
DO NOT REPRODUCE OR DISCLOSE TO
OTHERS WITHOUT EXPRESS WRITTEN
CONSENT OF IRI/PINWEL.

DWG. NO. 804947		REV. 1	REV. R
REV.	DESCRIPTION	DATE	BY
10067	Q	PRODUCED CAD DRAWING	03.08.10 LWF
11016	R	ADDED ITEM 55	24.11 BB

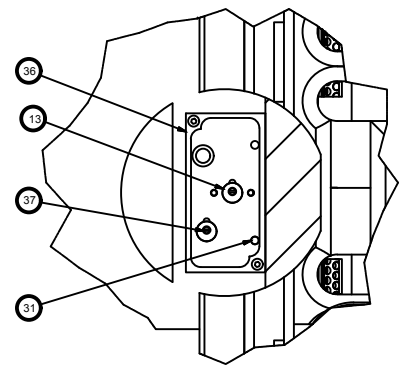

DETAIL J
SCALE 1 / 2

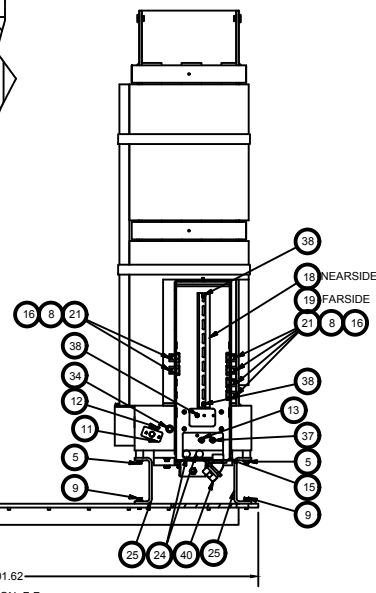

SECTION F-F
SCALE 1 / 8

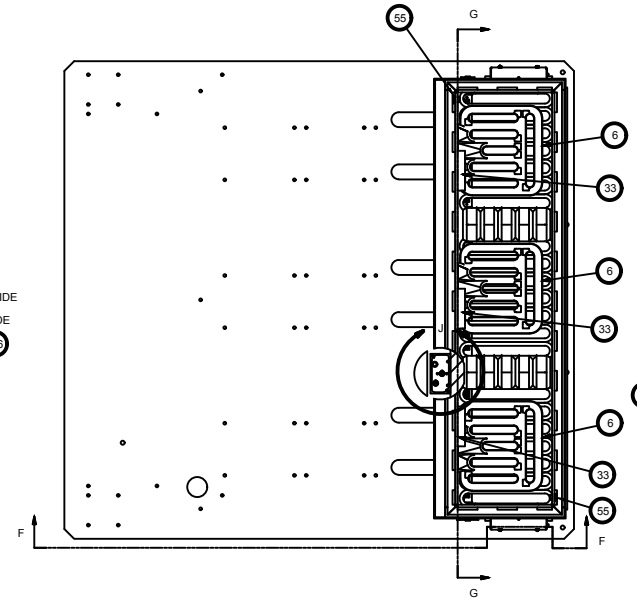

SECTION G-G
SCALE 1 / 8

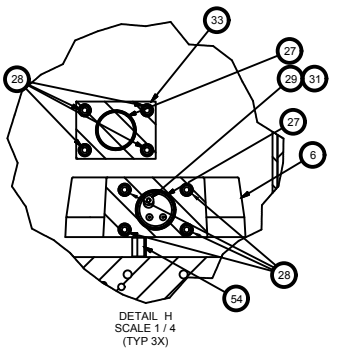
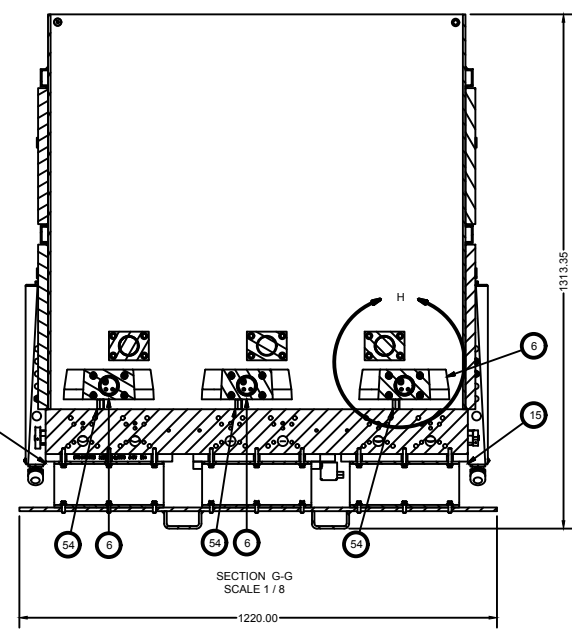

DETAIL H
SCALE 1 / 4
(TYP 3X)

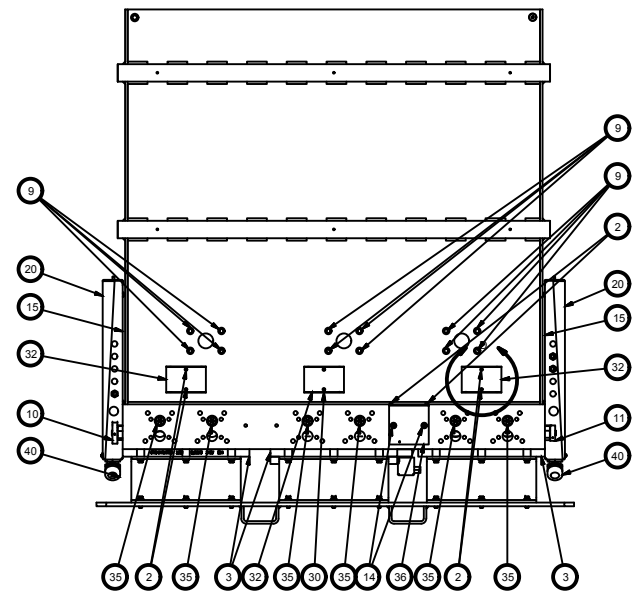
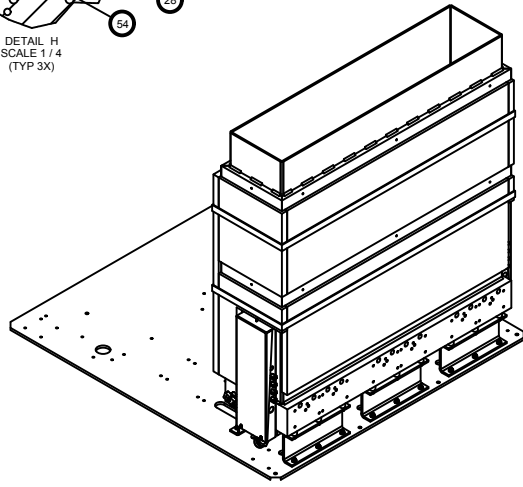

SECTION E-E
SCALE 1 / 8

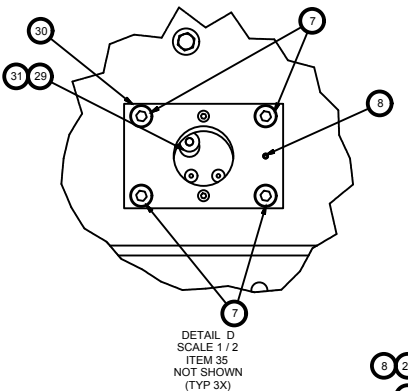

DETAIL D
SCALE 1 / 2
ITEM 35
NOT SHOWN
(TYP 3X)

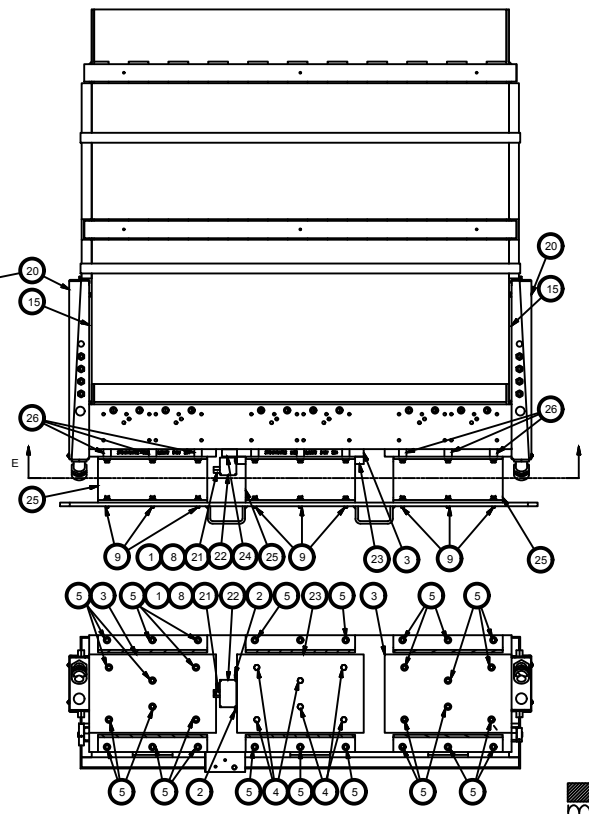
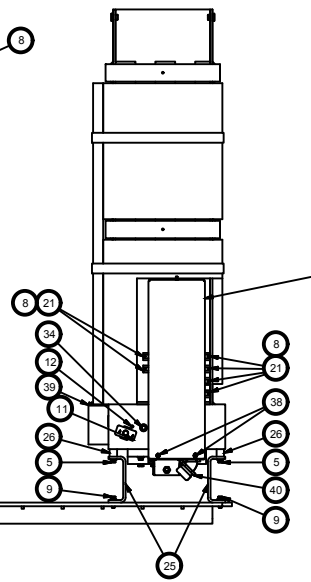

ITEM	PART NUMBER	QTY	UM	DESCRIPTION
55	101825	2	EA	PLUG, 1/4 BSPP
54	811278	3	EA	GRID SUPPORT DMM
53	108779	1	EA	KIT,HPR,INSL,M210,SNGL
52	804930	1	EA	HOP,AS,SIN,DMM210,VHT
51	109235	1	EA	CONDUIT,5/16,SST,32"LONG
50	108832	2	EA	WIRE,ASY,MID,HTR,PLT,M210
49	108831	2	EA	CONDUIT,3/4"SEALTITE,36"
48	108706	1	EA	WIRE,ASY,GND,HOPPER,DMM
47	108567	2	EA	WIRE,ASY,HI TEMP,T'STAT
46	107646	2	EA	CONDUIT,5/16,SST,28"LONG
45	107645	2	EA	CONDUIT,5/16,SST,12"LONG
44	048J088	2	EA	3/4" STRGHT CONDUIT FITT
43	048J064	4	EA	BUSHING, 3/4" INSULATING
42	048J049	2	EA	FTG, 1/4" COND, 9/16-18
41	048J048	4	EA	1/4ID CONDUIT (UIT302)
40	048J014	2	EA	3/4 45 DEG. FITTING
39	108565	1	EA	CVR,BLK,HTR,CTRL,DMM
38	107389	14	EA	SCR,PHP,M4X8,W/SHR
37	036B015	3	EA	T'STAT, N.O. 1/2 DIA.
36	108564	1	EA	BLK,HTR,CTRL,DMM
35	803837	6	EA	SEAL,PUMP TO ASU,-021 PAROFLUOR
34	072X093	2	EA	1/2 NPT LEVEL SEAL, PLUG
33	105149	3	EA	PLATE, GRID BLOCK OFF, MET
32	003E023	3	EA	COVER
31	036B103	6	EA	SNSR,RTD,PT100,187X1.25,HT,LDS
30	104696	3	EA	PLT,BKG,GRID,MET
29	106174	3	EA	ADPTR,SNSR,GRID
28	N07081	24	EA	O-RING,-014,70 DUR, PAROFLUOR
27	069X285	6	EA	O-RING,-032,75 DUR, PAROFLUOR
26	105135	18	EA	INSUL/SPACER, 75
25	105999	6	EA	BRKT,HPR,SUPT,DMM70/140/
24	102411	6	EA	CAP,HI TEMP, 60 IDX1.5L
23	106000	1	EA	SPCR,HTR,PLT,DMM210
22	106719	1	EA	BOX,J,DMM210
21	107751	12	EA	FTG,5/16" COND,9/16-18
20	106001	2	EA	CVR,JBOX,DMM
19	105974	REF	EA	PLATE,BASE,DMM210
18	108813	1	EA	TERM RAIL,ASY,M210
17	107441	1	EA	TERM RAIL,ASY,LG,DMM
16	N06883	11	EA	NUT,HEX,JAM, 9/16-18,STL
15	105885	2	EA	J-BOX,DMM
14	105110	2	EA	SCR,M8X55,ALLEN
13	036B013	3	EA	T'STAT, N.C. 1/2 DIA.
12	105097	2	EA	SHSS,M8X30,BLK,OX
11	804948	1	EA	FLTR/SHTOFF,AS,SING,DMM,HT
10	804465	1	EA	FLTR/SHTOFF,AS,RH,DMM,HT
9	108297	30	EA	SCR,HH,SER,FL,M8-1.25X20
8	106156	16	EA	SHSS,M4X6,BLK,OX
7	N07429	12	EA	SCR,SKT,HD,M8-1.25 X 30M
6	104802	3	EA	GRID,MACH,KNF,DM
5	107602	30	EA	SCR,HH,SER,FL,M8-1.25X40
4	803945	6	EA	SCR,M8-1.25X60,HHCS,8.8
3	105881	3	EA	HTR,PLT,5000W,240V,DM-M
2	102446	10	EA	SCR,SHG,M4-0.70X10
1	0780022	1	EA	9/16-18 JAM NUT

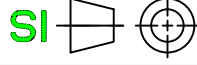

FOR MACHINING STANDARDS AND SYMBOLS, SEE IRI/DYNATEC SPEC. ACCORD TO: 30-3238	APPROVALS LWF LWF DATE 03.08.10 03.08.10	rwDynatec HEDERSHOLLE, TH	U/M EA STATUS P SOURCE TO
USED ON 224643	CHECKED LWF DATE 03.08.10	GRID GROUP DMM210 SINGLE HT	DWG. NO. 804947 SCALE 1:8
NEXT ASSY: 804929	COMPUTER DESCRIPTIONS CHARACTER GRID_GRP,DMM210,SING,HT	DWG. NO. 804947 SCALE 1:8	REV. R GROUP 00 SHEET 1 OF 1

10.3.4 Filter and Shutoff Asy, right-hand, PN 105968, and high-temp version, PN 804465

NOTE: M210 has two filter and shutoff assemblies, one on the right side (105968 or 804465) and one on the left side (105969 or 804948) of the hopper (tank).

The 105969 (or 804948 high-temp version) is long enough to cover four pumps and the 105968 (or 804465 high-temp version) is long enough for the other two pumps for a total of six pumps.

NOTE: This assembly drawing is shown for reference only! The filter and shutoff assembly must be ordered as entire assembly. Only the O-rings and the lube can be ordered separately.

Item	Part Number	Description	Quantity
1	-	Filter cartridge (tube)	1
2	-	Roll pin 1/8x13/16	1
3	-	Stem	1
4	N00210	O-ring 912	1
	N07088 **	O-ring 912, Parafluor	1
5	-	Knob	1
6	N00181	O-ring 014	1
	N07081 **	O-ring 014, Parafluor	1
7	-	Roll pin 1/8x1	1
8	-	Nut	1
9	001V078	High-temp lube, TFE, Krytox GPL206 (not shown)	A/R*
10	-	Tube, perforated	1

** Parts for Filter and Shutoff Asy, right-hand, high-temp, PN 804465.

A/R* = As required.

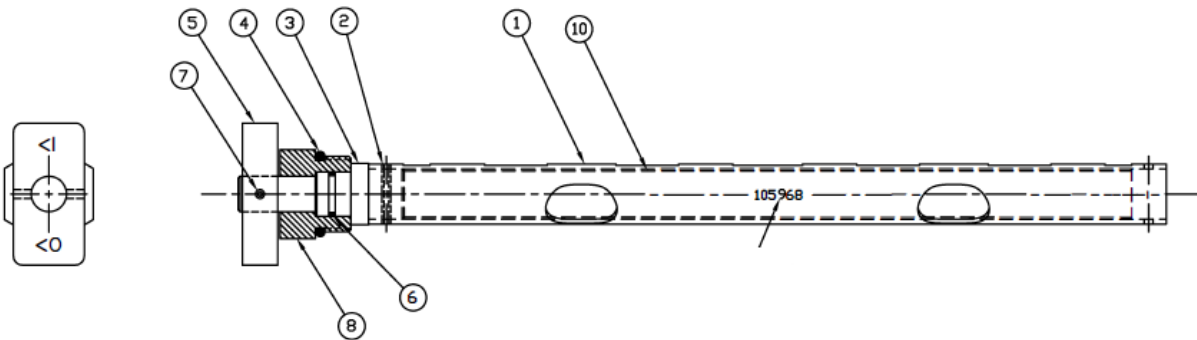

NOTES:

1. Coat O-rings (items 4 and 6) with high-temp lubricant (item 9) prior to assembly.
2. Knob (item 5) must be positioned with arrows in the orientation shown at assembly.
3. Grind ends of roll pin (item 7) flush with outside diameter of filter cartridge (tube) (item 1).

10.3.5 Filter and Shutoff Asy, left-hand, long, PN 105969, and high-temp version, PN 804948

NOTE: M210 has two filter and shutoff assemblies, one on each side of the hopper (tank). The 105969 (or 804948 high-temp version) is long enough to cover four pumps and the 105968 (or 804465 high-temp version) is long enough for the other two pumps for a total of six pumps.

NOTE: This assembly drawing is shown for reference only! The filter and shutoff assembly must be ordered as entire assembly. Only the O-rings and the lube can be ordered separately.

Item	Part Number	Description	Quantity
1	-	Filter cartridge (tube)	1
2	-	Roll pin 1/8x13/16	1
3	-	Stem	1
4	N00210	O-ring 912	1
	N07088 **	O-ring 912, Parafluor	1
5	-	Knob	1
6	N00181	O-ring 014	1
	N07081 **	O-ring 014, Parafluor	1
7	-	Roll pin 1/8x1	1
8	-	Nut	1
9	001V078	High-temp lube, TFE, Krytox GPL206 (not shown)	A/R*
10	-	Tube, perforated	1

** Parts for Filter and Shutoff Asy, single, high-temp, PN 804948.
A/R* = As required.

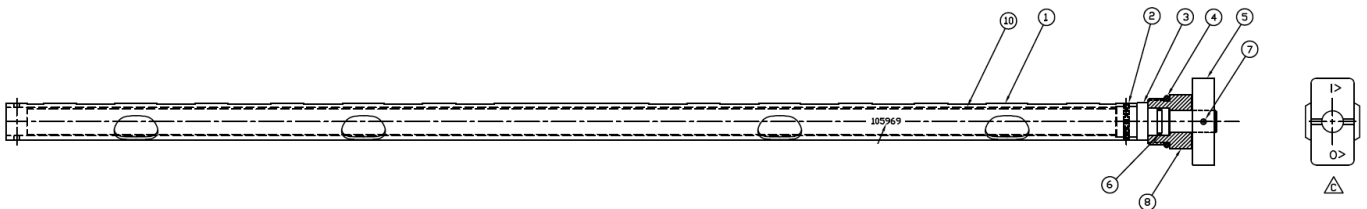

NOTES:

1. Coat O-rings (items 4 and 6) with high-temp lubricant (item 9) prior to assembly.
2. When installing the perforated tube (item 10), line up holes with the oval openings in item 1.

10.4 Filter Manifolds

10.4.1 Filter Manifold Assembly, Easy-Spin, for dual pump, PN 814016

Note: For heaters refer to “Heater control groups” in this chapter.

Item No.	Part Number	Description	Quantity
01	102713	Heater retainer plate	1
02	105099	Screw M8x25mm	2
03	810250	Screw M8x110mm	5
04	See order	Fitting G1/2 BSPP to JIC	2
05	107820	Purge valve 1/4 BSPP	2
06	101625	Plug screw G1/4	10
07	814017	Cap for filter nut	1
08	808217	Adjustable relief valve 0-50bar (0-750psi)	2
09	808349	Screw M6x20mm	6
10	See order	Filter cartridge Easy-Spin Options: 814007 Filter cartridge, 40 Mesh 814008 Filter cartridge, 80 Mesh 814009 Filter cartridge, 100 Mesh (standard) 814010 Filter cartridge, 150 Mesh 814011 Filter cartridge, 200 Mesh	2
11	N00187	O-ring 020, 70 Duro Viton	4
12	A69X133	O-ring 124, 75 Duro Viton	2
13	812816	O-ring 127, 75 Duro Viton	2
14	814018	Filter nut	2
15	112282	Dowel pin 4x10mm	2
16	814019	Filter manifold	1
17	001U002	Lube Silicon Dow 112	A/R*
18	107324	Compound antiseize, temperature resistant	A/R*
19	N00753	Fitting plug NPTF 1/8	1
20	102712	Cover plate	1
21	N00181	O-ring 014, 70 Duro Viton	6
22	N00185	O-ring 018, 70 Duro Viton	2
23	102717	Check valve 1-way	2

A/R* = As required.

NOTE:

- 1. Item 10 has left hand threads. Use caution when installing on item 14.
- 2. Item 14 is correctly installed when top surface is flush with item 07.
- 3. Item 06 quantity may change if pressure transducers are used.
- 4. When servicing this assembly, remove all sources of energy.
- 5. To remove residual pressure within the filter manifold, use the bleed valve item 05. The bleed valve uses a 5mm Allen wrench. Counterclockwise opens the valve, clockwise closes it.
- 6. When returning this assembly to service, check for leakage after pressurization.
- 7. Install the fitting (item 19) for dual pump (dual stream). Remove item 19 to combine dual pump or single pump.

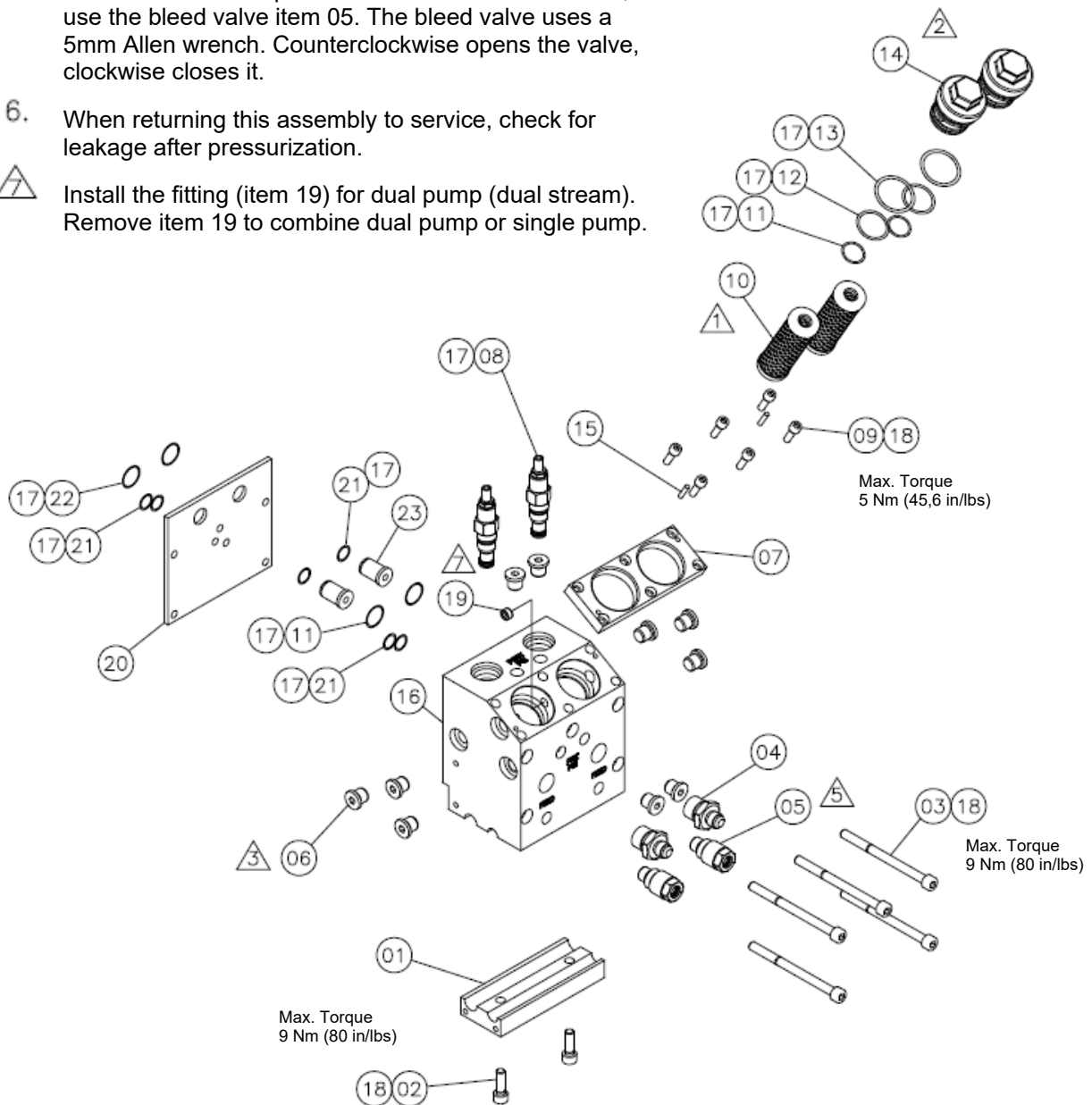

Illustration: Filter Manifold Assembly, Easy-Spin, for dual pump, PN 814016

10.4.2 Filter Manifold Assembly, Easy-Spin, for single pump, PN 825653

Note: For heaters refer to “Heater control groups” in this chapter.

Item No.	Part Number	Description	Quantity
01	102713	Heater retainer plate	1
02	105099	Screw M8x25mm	2
03	810250	Screw M8x110mm	5
04	See order	Fitting G1/2 BSPP to JIC	2
05	107820	Purge valve 1/4 BSPP	1
06	101625	Plug screw G1/4	11
07	814017	Cap for filter nut	1
08	808217	Adjustable relief valve 0-50bar (0-750psi)	1
09	808349	Screw M6x20mm	6
10	See order	Filter cartridge Easy-Spin Options: 814007 Filter cartridge, 40 Mesh 814008 Filter cartridge, 80 Mesh 814009 Filter cartridge, 100 Mesh (standard) 814010 Filter cartridge, 150 Mesh 814011 Filter cartridge, 200 Mesh	2
11	N00187	O-ring 020, 70 Duro Viton	4
12	A69X133	O-ring 124, 75 Duro Viton	2
13	812816	O-ring 127, 75 Duro Viton	2
14	814018	Filter nut	2
15	112282	Dowel pin 4x10mm	2
16	814019	Filter manifold	1
17	001U002	Lube Silicon Dow 112	A/R*
18	107324	Compound antiseize, temperature resistant	A/R*
19	-	-	-
20	102712	Cover plate	1
21	N00181	O-ring 014, 70 Duro Viton	6
22	N00185	O-ring 018, 70 Duro Viton	2
23	102717	Check valve 1-way	2
24	814952	Relief valve plug	1

A/R* = As required.

NOTE:

- 1. Item 10 has left hand threads. Use caution when installing on item 14.
- 2. Item 14 is correctly installed when top surface is flush with item 07.
- 3. Item 06 quantity may change if pressure transducers are used.
- 4. When servicing this assembly, remove all sources of energy.
- 5. To remove residual pressure within the filter manifold, use the bleed valve item 05. The bleed valve uses a 5mm Allen wrench. Counterclockwise opens the valve, clockwise closes it.
- 6. When returning this assembly to service, check for leakage after pressurization.

NOTE: Do not install plug between filter chambers on this assembly.

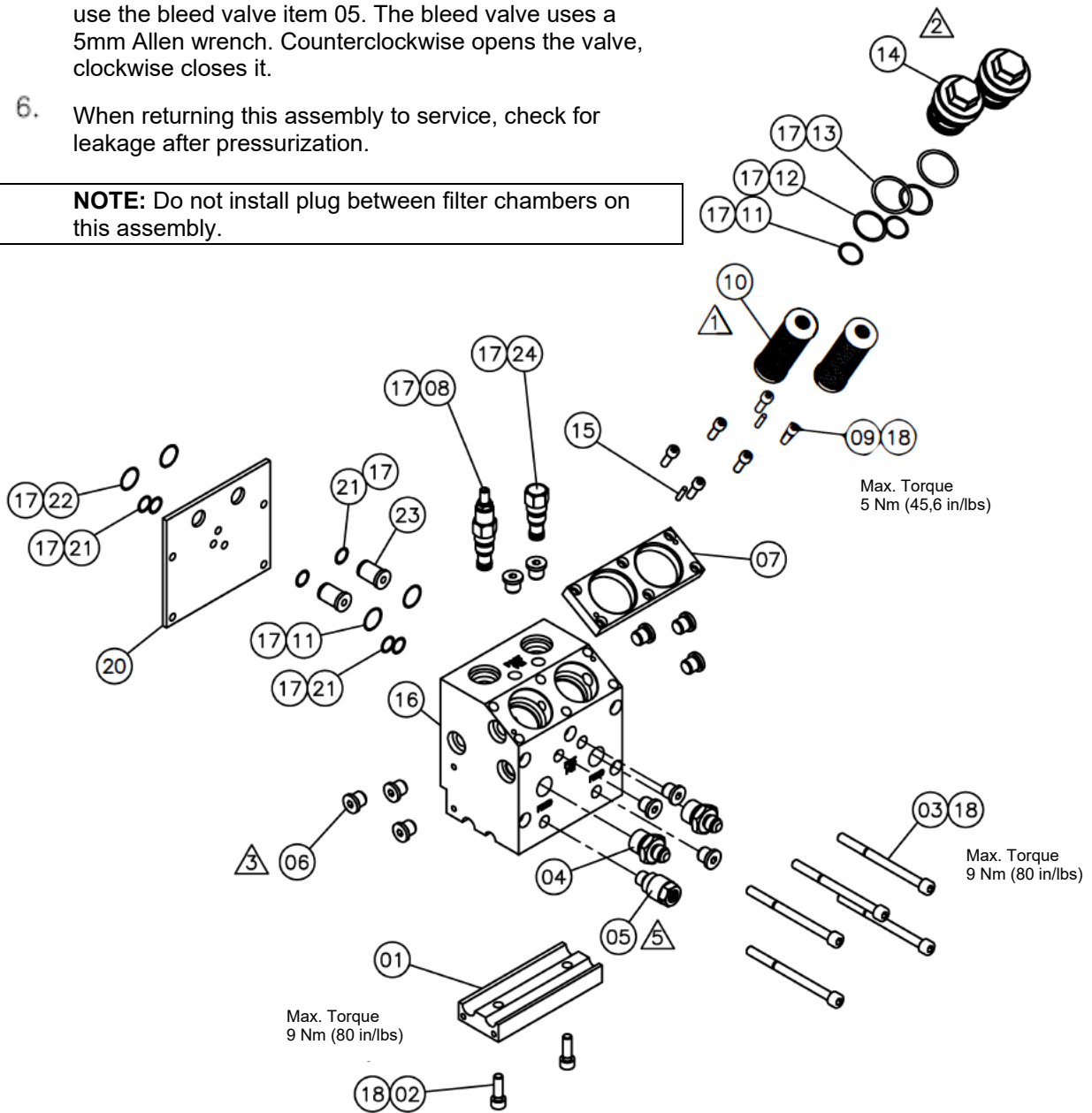

Illustration: Filter Manifold Assembly, Easy-Spin, for single pump, PN 825653

10.4.3 Hi Volume/ Hi Flow Filter & Pressure Relief Assembly, PN 809534

Item No.	Part Number	Description	Quantity
1	N00185	O-ring 018	6
2	003D105	Heater plate	1
3	006B043	Heat Isolator	1
4	809533	Filter block	2
5	806182	Filter nut	2
6	See order	Large Filter Basket Options: 807796 Large Filter Basket, 20 Mesh (option) 807797 Large Filter Basket, 40 Mesh (option) 807798 Large Filter Basket, 80 Mesh (option) 807799 Large Filter Basket, 100 Mesh (option) 807800 Large Filter Basket, 120 Mesh (option)	2
7	806188	Filter retainer plate	2
8	006G064	Block	2
9	006G078	Spring	2
10	012G001	Piston	2
11	012G010	Pressure relief screw	2
12	048D141	Junction box	1
13	048D142	Cover	1
14	N00220	Snap-in hole plug	1
15	048J022	Conduit fitting 3/8" straight	1
16	806206	O-ring 333	2
17	104733	Level seal plug 1/2 NPT	4
18	006G112	Cap	2
19	078A005	Screw 10-24 x 1/2 SHC	4
20	N04458	Dowel pin 1/4	4
21	N00838	Screw 3/8-16 x 1 1/4 SHC	8
22	N00839	Screw 3/8-16 x 1 3/4 SHC	4
23	078A164	Screw 10-24 x 1/2 HHSM	1
24	N07790	Screw 3/8-16 x 4 1/4 SHC	4
25	078A337	Screw 3/8-16 x 5 1/2 SHC	4
26	078A379	Screw 1/4-20 x 4 1/2 SHC	6
27	078D027	Jam nut 3/4-16	2
28	078C005	Flat washer 8	4
29	078C021	Flat washer 0.88x1x0.13	1
30	101833	Tamper proof screw 10-32	2
31	807188	Drain plug	2
32	N00754	Level seal plug 1/4	4
33	N00755	Level seal plug 3/8-18 NPT	2
	807179	Heater Control Section:	1
34	036A079	Heater 5/8x10, 240V, 1000W	3
35	036B013	Thermostat NC 1/2 Dia.	1
36	106174	Sensor adapter	1
37	N07958	Temperature sensor RTD, PT100, Ø 0.1875x1.25" (Ø 0.48x3.18cm), leads 48" (122cm)	1
38	807543	Hi volume filter nut cover assembly (option)	2
39	807542	Cover plate	1
40	N00817	Screw 1/4-20 x 1.25 SHC	4

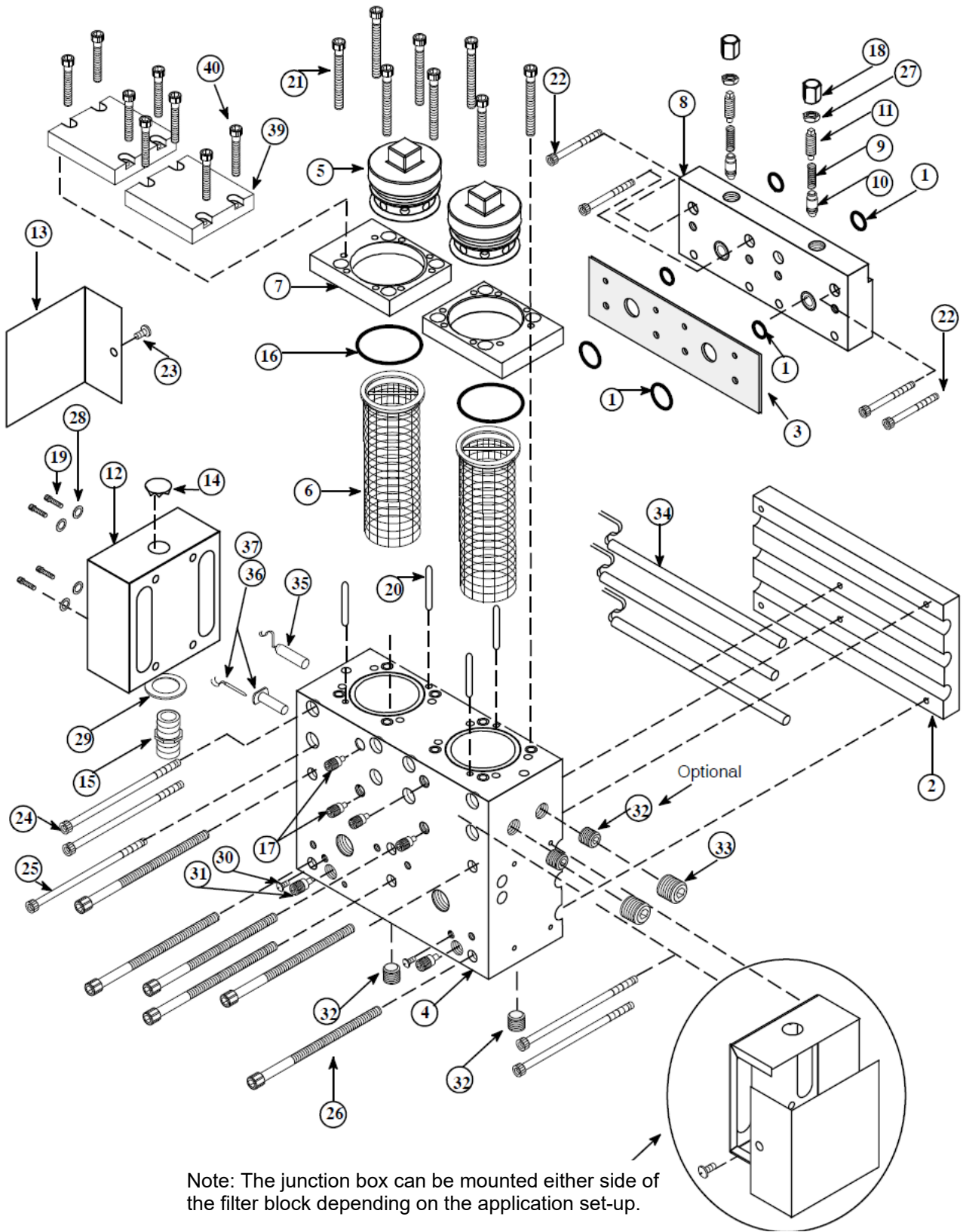

Illustration: Hi Volume/ Hi Flow Filter & Pressure Relief Assembly, PN 809534

10.5 Typical Electrical Panel Box Assembly, M210 DCL V6

Item No.	Part Number	Description	Quantity
1	820486	HMI mounting bracket, V6	1
2	-	-	-
3	118135	V6-Touch Panel Assembly	1
	115893	V6-PCB asy, LCD (option)	1
	118147	Memory Card, V6 Touch, (not shown)	1
4	102328	Panel box lock kit	2
5	103377	Wire duct, 1,5" W x 3" H	7
	103378	Wire duct, 2" W x 3" H	8
	104084	Wire Duct, 1"W x 2.25"H	8
	810112	Wire Duct, 3"x3"x6"	4
6	103439	Wire duct cover 1,5"	7
	103438	Wire duct cover 2.25"	8
	105179	Wire Duct Cover, 1"	8
	810113	Wire Duct Cover (fits PN 810112)	4
7	821939	Rotary Handle, Shaft & Mechanical Operator for Main CB (400V)	1
	821940	Rotary Handle, Shaft & Mechanical Operator for Main CB (240V)	1
8	823306	V6-Power PCB, V6-power supply	1-3
9	118584	Solid State Relay (SSR) Adapter PCB Assy	3
10	821938	Main Circuit Breaker, 150A, 240V (240V models)	1
	821937	Main Circuit Breaker, 125A, 690V (400V models)	1
11	820949	Panel Box	1
12	See main BOM	Insert Panel	1
13	114232	Solid State Relay, dual, 40A, 240VAC, 24V	12
14	823305	Heat sink plate, V6	3
15	809489	Fan filter	1
16	815007	Exhaust grill kit	1
17	815146	Harting Interface Connector (option)	1
18	105981	Top panel	1
19	118928	Bulkhead Connector for USB Port (not shown)	1
20	118929	Bulkhead Cap for USB Port (not shown)	1
21	118930	Cable, USB, 1m (not shown)	1

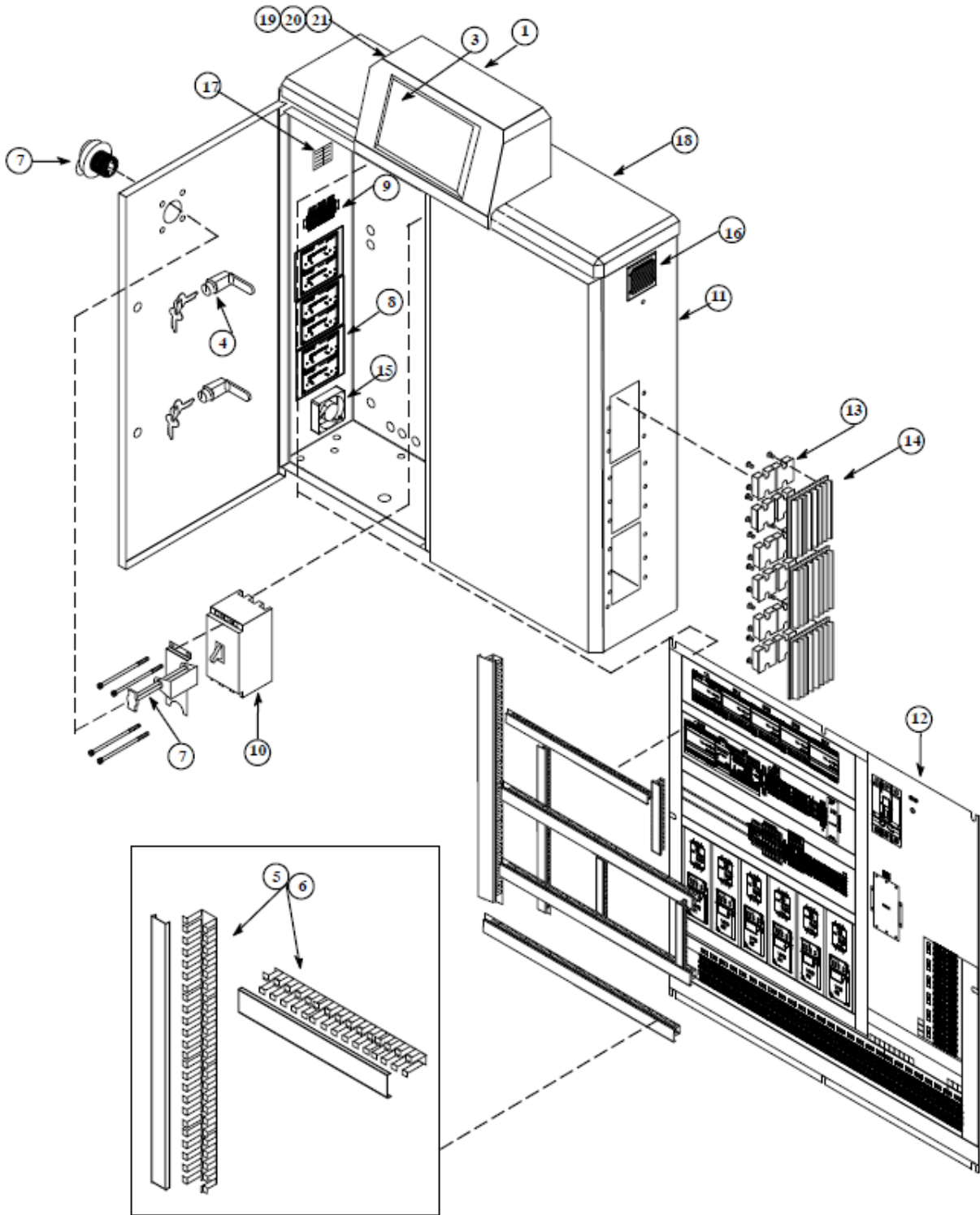
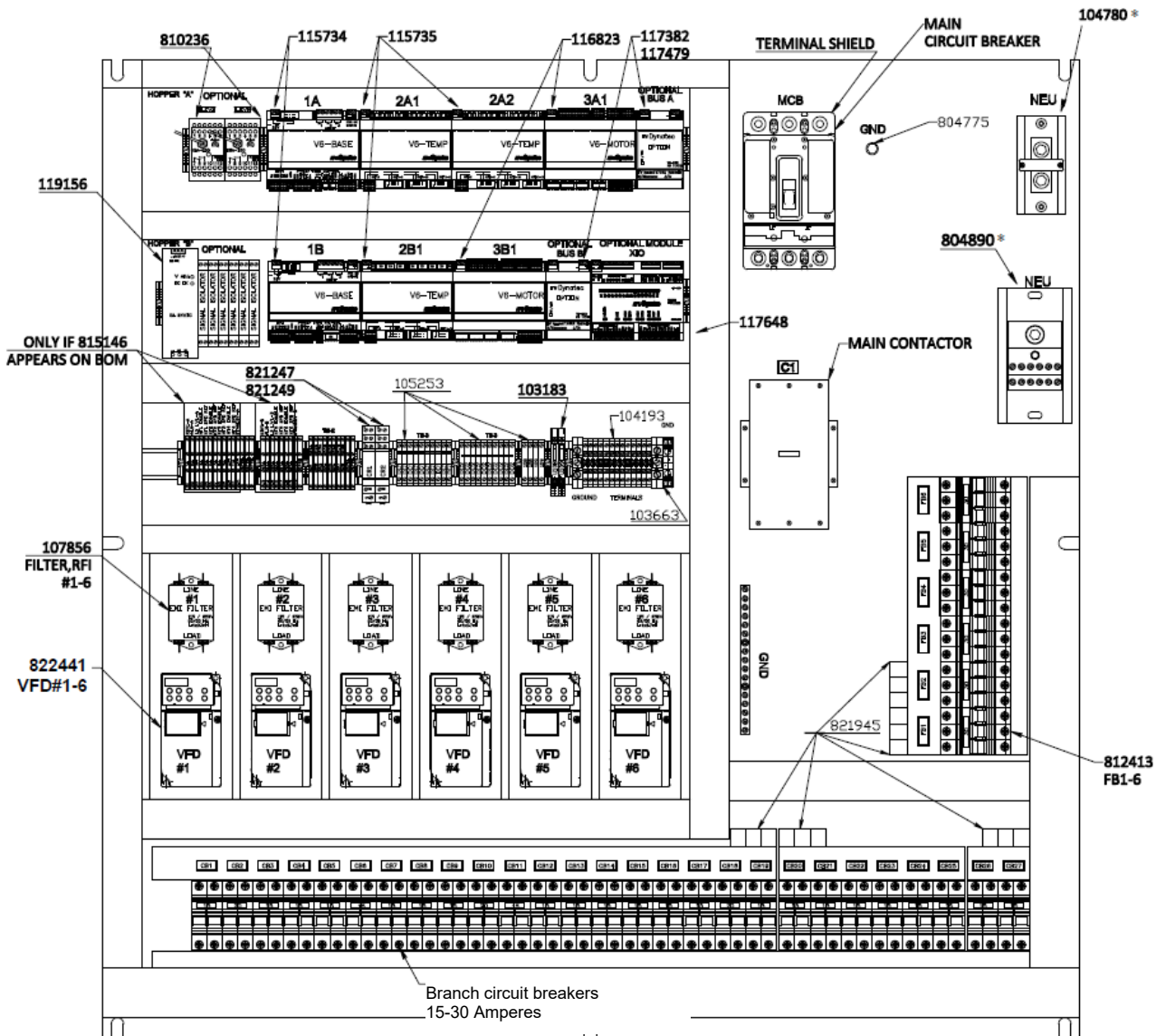

Illustration: Typical Electrical Panel Box Assembly, M210 DCL V6

10.6 Typical Electrical Panel Box Insert Components, M210 DCL V6

Part Number	Description	Quantities depend on model
048i126	Fuse holder 0.4x1.5in	1
107856	Filter, RFI, 240V, 10A, Line	1-6
115734	V6-Base Module	1-2
115735	V6-Temperature Module	3
116823	V6-Motor Modul	2
117143	V6-Signal Isolator	1-6
118125	V6-Communication Modul	1-2
117479	V6-EtherNet Adapter	1
119156	Power supply 24VDC 6A	1
118584	V6-SSR Adapter PCB	3
804534	Fuse 30A, LP-CC, 1,5x. 4in	4-20
804775	Ground Post	1
810236	Amplifier, Level Control (option)	1-2
812413	Fuse block 3ph. LPCC (240V model only)	1-6
822441	Motor Speed Control Kit, 1 HP, Y, (contains 815223)	1-6
821247	Relay DPDT 24VDC	1-2
821748	Contactora 3ph. 160A, 240VAC coil	1
821937	Main circuit breaker 125A, 225F, 690V, 3P, FWF (400V units)	1
or 821938	Main circuit breaker 150A, 240V (240V units)	1
821941	Terminal shield for main circuit breaker (240V)	1
821942	Terminal shield for main circuit breaker (400V)	1
822087	IP20 Terminal Shield for Contactora	2'
104207	Circuit breaker 15A, 2P (240V units only)	max. 24
104391	Circuit breaker 20A, 2P (240V units only)	max. 3
811301	Circuit breaker 15A, 1P (400V units only)	max. 24
811302	Circuit breaker 20A, 1P (400V units only)	max. 3
811581	Circuit breaker 30A, 2P (400V units only)	max. 6
TERMINALS:		
103663	Terminal block #6 Ground (400V model only)	1
104193	Terminal block Ground 4pl. 30A (240V model only)	13
105251	Terminal block dual Wk4e/U, 10A	32-40
105253	Terminal block single Rk254,20	30
804890	Neutral Block, 350mcm/4.14x12 (400V units only)	1
805198	Bar, Grounding, 14hole 14-6	1
821943	Bus bar, 3ph. 100A	1-1.5
821945	Bus bar feeder terminals, 35mm	9-12
821946	Bus bar end cap	6-8



* Neutral is only used for 400V units (2 parts)

Illustration: Typical Electrical Panel Box Insert Components, M210 DCL V6

10.7 Drive Assemblies

- Front Drive assembly, 1HP AC, 20:1, PN 106660 (includes PN 108819 Motor & Gear Box Ass)
- Rear Drive assembly, 1HP AC, 20:1, PN 106663 (includes PN 108819 Motor & Gear Box Ass)

Note: the PNs with a "*" are part of PN 108819 Motor & Gear Box Ass.

Item No.	Part Number	Description	Qty.
1	106874	Coupling Half, Pump Side (option, not part of drive assembly)	1
2	106875	Coupling, Open Spider	1
3	104663	Screw M6- 1.0 x 25mm, SHC	4
4	106714	Coupling, Half, Motor Side	1
5	106658	Shaft, Gearbox, 20:1 (Front Drive Assembly PN 106660)	1
	106661	Shaft (Rear Drive Assembly PN 106663)	1
6	106662 *	Gear Box, 20:1	1
7	822569	Key, 6mm ² , 18mm long, V2	3
8	106754	Ring Clip	2
9	106659 *	Motor Mounting Bracket	1
10	107602	Screw M8 x 40mm HHC	2
11	105060 *	Nut M8	2
12	801679 *	Motor, AC, 3P, 240v, 1HP, K256	1
13	106324	Flat Washer, M6	8
14	106319	External Tooth Lock Washer, M6	4
15	N00732	Screw 5/16-18 x 3/4 SHC	8
16	N00933	Lock washer 5/16	8
17	N00687	Flat washer 5/16	8
18	106342 *	Adapter Plate	1
19	078A183	Screw 3/8-16 x 1 HHC	4
20	106341	Set Screw M8-1.25 x 40mm SH	4
	N00053	Terminal 16-14GA (not shown)	1
	808916	Optional Pneumatic Clutch Assembly (items 22-29)	1
22	030A014	Solenoid, 120V, 3- way	1
23	048J184	Cord Grip, 1/8 - 1/4	1
24	072X004	Hex Nipple 1/8	1
25	106877	Clutch Kit, 56C, In line	1
26	N00099	Fitting, Elbow, 90deg., Brass	1
27	N02745	Muffler, Pneumatic Exhaust, 1/8 NPT	1
28	N07677	Tubing, TFE, .25 OD x .125 ID	4'
29	N08236	Cable, 18ga, 3C, SV	10'
	110504	Optional Clutch Air Manifold Assembly (items 31-36)	1
31	110503	Air Manifold	1
32	N00093	Fitting, 1/4 tube x 1/8 NPT	7
33	N00753	Level Seal Plug 1/8 NPT	1
34	101692	Screw M4-0.7 x 35mm SHC	4
35	106198	Lock Washer, 4mm	4
36	822453	Key, mach, 3/16x3/16x1-3/4	1

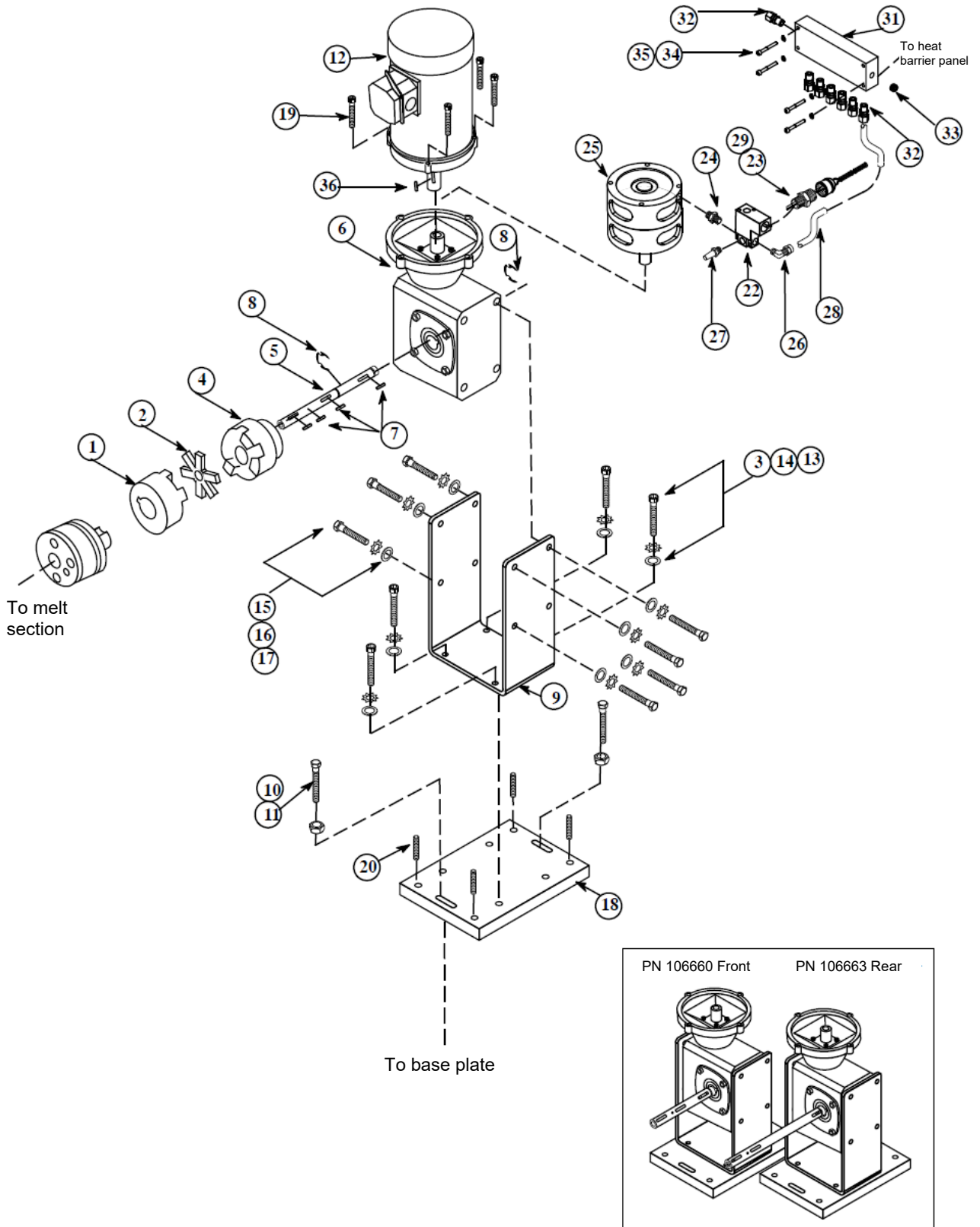
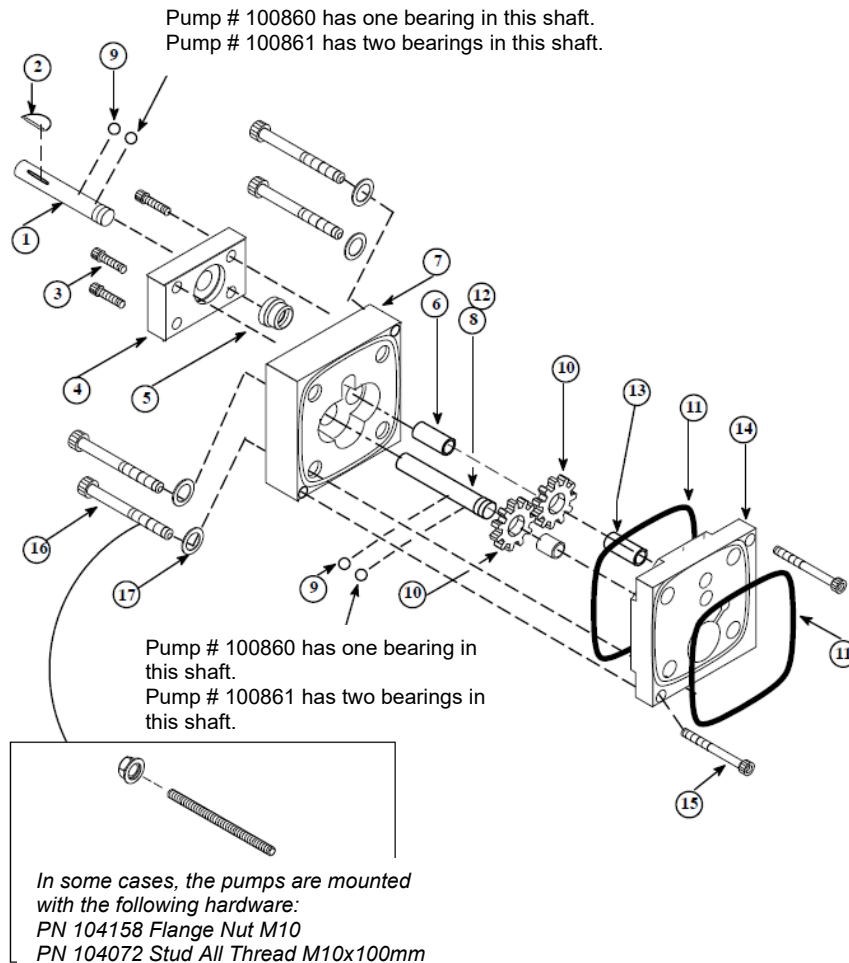

Illustration: Drive Assemblies

10.8 Gear Pumps & Adapter Kits

10.8.1 Single Gear Pump Assembly 1.54 cc/rev, PN 100860 and 3.2 cc/rev, PN 100861

Item No.	Part Number 100860	Part Number 100861	Description	Quantity
1	012D079	012D077	Drive Shaft	1
2	078I001		Key, Woodruff	1
3	101626		Screw M5x12mm	4
4	069X160		Seal Retainer & Bearing Housing	1
5	069X061		Shaft Seal	1
6	018X041		Bearing Sleeve	2
7	100866	100867	Front Plate Assembly	1
8	012D080	012D078	Driven Gear Shaft	1
9	018X031		Ball, 1/8" Diameter (see illustration for quantity)	2-4
10	012C020	012C019	Drive Gear	2
11	069X064		O-ring 041, Pump Seal	2
12	078F017		Shaft Retaining Ring	4
13	018X041		Bearing Sleeve, Rear Plate	2
14	100865		Rear Plate Assembly	1
15	100908		Screw M4x25mm	2
16	104775	104776	Screw M10x75mm / M10x80m	4
17	-		Flat washer M10	4



10.8.2 Single Gear Pump Assembly 4.50 cc/rev., PN 100862

Item No.	Part Number	Description	Quantity
1	012D072	Drive Shaft	1
2	078I001	Key, Woodruff	1
3	101626	Screw M5x12mm	4
4	069X160	Seal Retainer & Bearing Housing	1
5	069X061	Shaft Seal	1
6	018X041	Bearing Sleeve	2
7	100868	Front Plate Assembly	1
8	012D073	Driven Gear Shaft	1
9	018X031	Ball, 1/8" Diameter	4
10	012C018	Drive Gear	2
11	069X064	O-ring 041, Pump Seal	2
12	078F017	Shaft Retaining Ring	4
13	018X041	Bearing Sleeve, Rear Plate	2
14	100865	Rear Plate Assembly	1
15	100908	Screw M4x25mm	2
16	104776	Screw M10x80mm	4
17	-	Flat washer M10	4

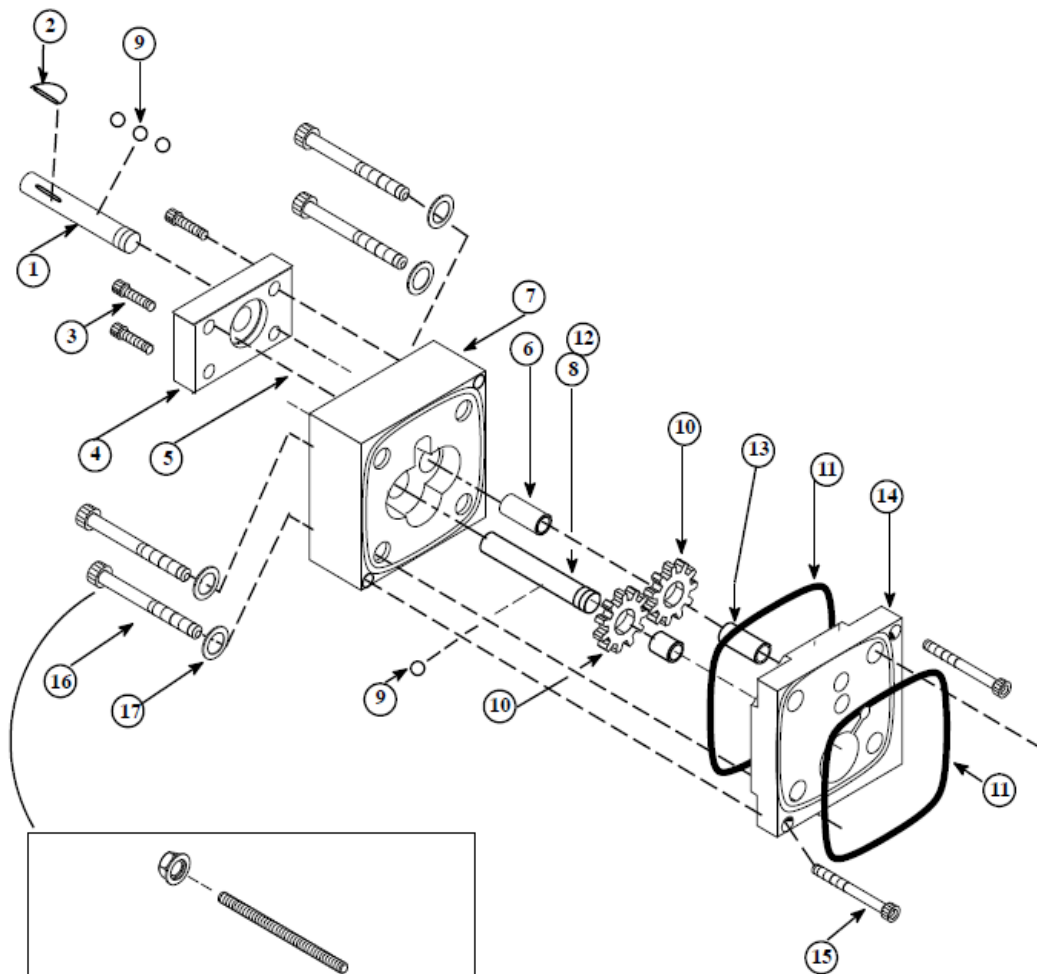

In some cases, the pumps are mounted with the following hardware:
 PN 104158 Flange Nut M10
 PN 104072 Stud All Thread M10x100mm

10.8.3 Dual Gear Pump Assembly 1.54 cc/rev., PN 100863

Item No.	Part Number	Description	Quantity
1	012D083	Drive Shaft	1
2	078I001	Key, Woodruff	1
3	101626	Screw M5x12mm	4
4	069X160	Seal Retainer & Bearing Housing	1
5	069X061	Shaft Seal	1
6	018X041	Bearing Sleeve	2
7	100866	Front Plate Assembly	1
8	012D082	Driven Gear Shaft	1
9	018X031	Ball, 1/8" Diameter	3
10	012C020	Drive Gear	4
11	069X064	O-ring 041, Pump Seal	3
12	078F017	Shaft Retaining Ring	4
13	018X041	Bearing Sleeve, Rear Plate	2
14	100865	Rear Plate Assembly	1
15	101692	Screw M4x35mm	2
16	-	Screw M10x85mm	4
17	100869	Middle Plate	1
18	N00198	O-ring 113	2
19	-	Flat washer M10	4

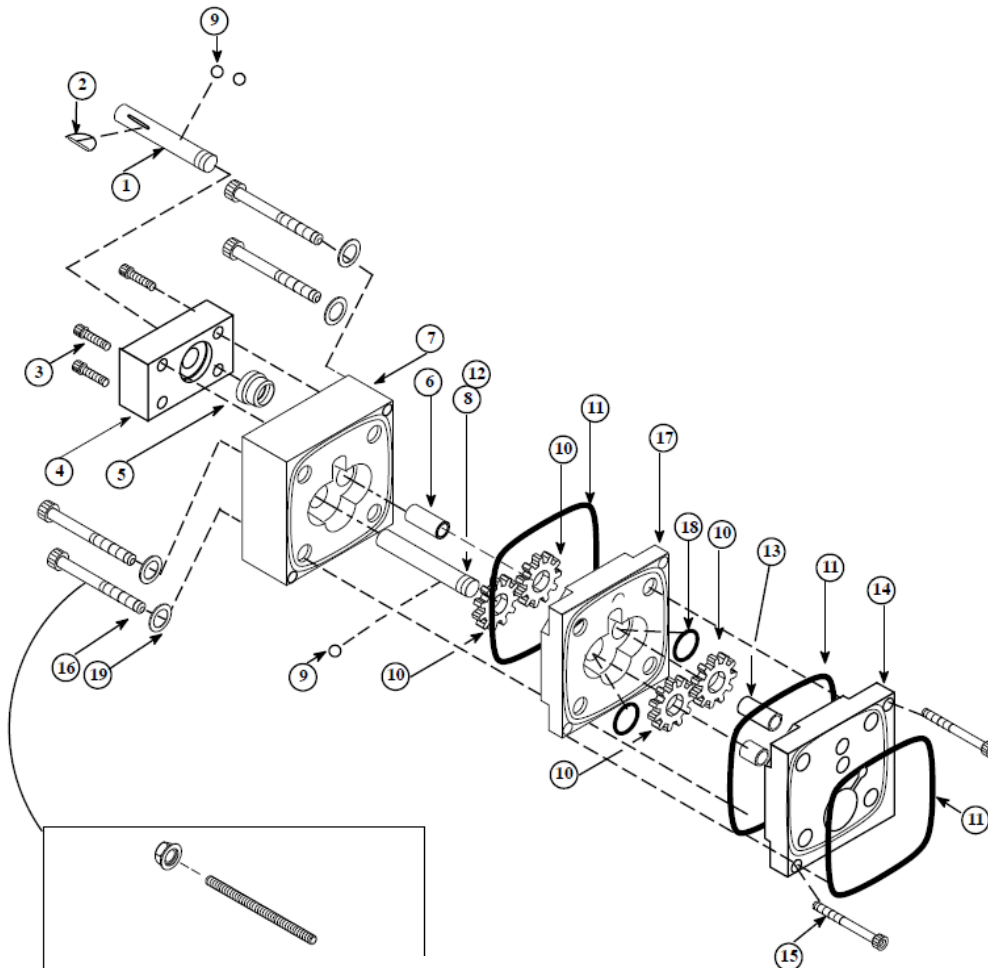

In some cases, the pumps are mounted with the following hardware:
 PN 104158 Flange Nut M10
 PN 104072 Stud All Thread M10x100mm

10.8.4 Dual Gear Pump Assembly 3.2 cc/rev., PN 100864

Item No.	Part Number	Description	Quantity
1	012D088	Drive Shaft	1
2	078I001	Key, Woodruff	1
3	101626	Screw M5x12mm	4
4	069X160	Seal Retainer & Bearing Housing	1
5	069X061	Shaft Seal	1
6	018X041	Bearing Sleeve	2
7	100867	Front Plate Assembly	1
8	012D087	Driven Gear Shaft	1
9	018X031	Ball, 1/8" Diameter (see illustration for quantity)	5
10	012C019	Drive Gear	4
11	069X064	O-ring 041, Pump Seal	3
12	078F017	Shaft Retaining Ring	4
13	018X041	Bearing Sleeve, Rear Plate	2
14	100865	Rear Plate Assembly	1
15	101691	Screw M4x40mm	2
16	-	Screw M10x85mm	4
17	100870	Middle Plate	1
18	N00198	O-ring 113	2
19	-	Flat washer M10	4

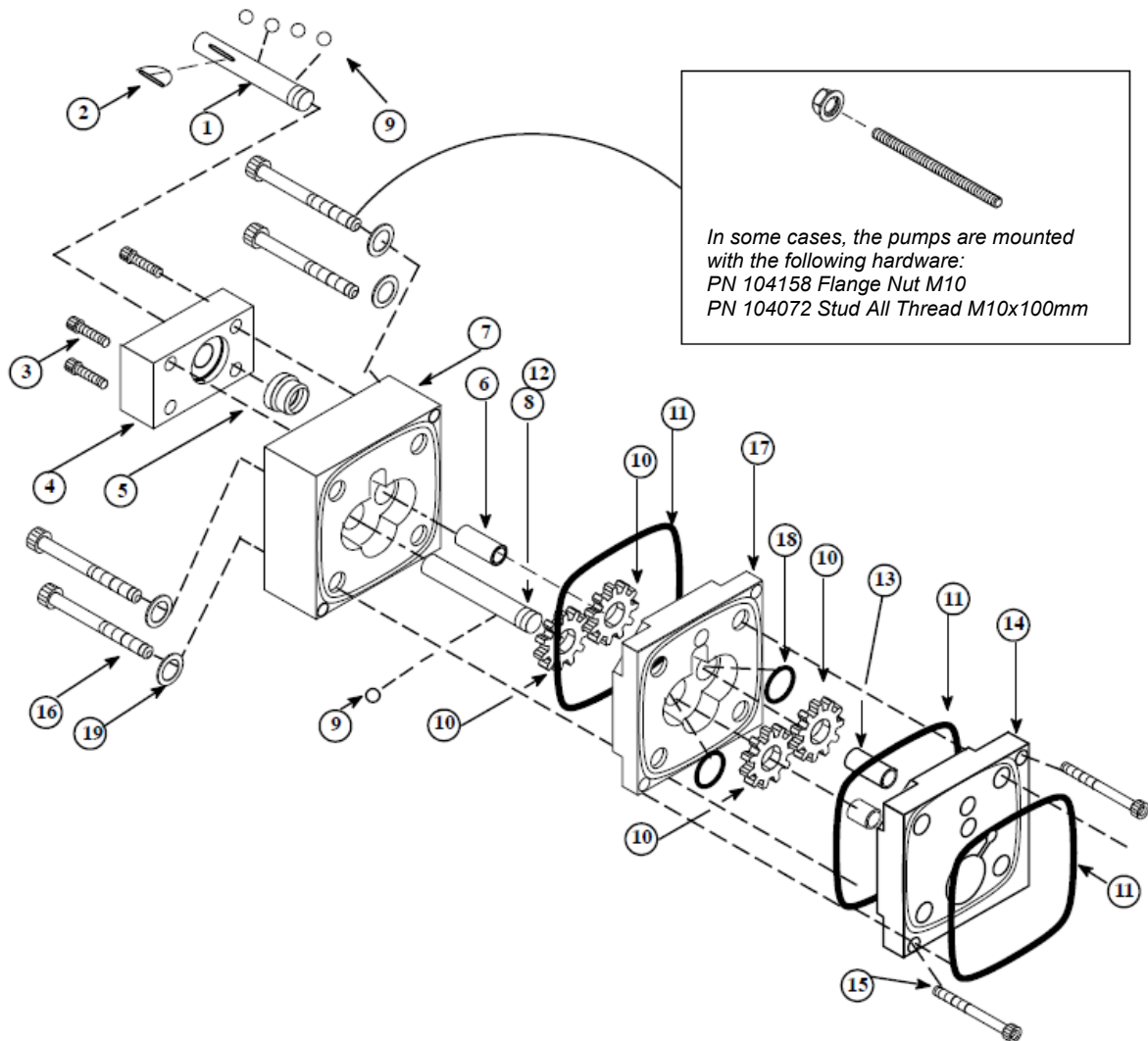

10.8.5 Single Gear Pump Assembly 10 cc/rev., PN 109690

Item No.	Part Number	Description	Quantity
1	018X031	Ball Bearing, 1/8 Diameter	6
2	078F017	Snap Ring, 1/2"	4
3	078I001	Key Woodruf	1
4	069X061	Shaft Seal	1
5	069X064	O-ring 041, Pump Seal	2
6	108588	Screw M4x25mm	2
7	101626	Screw M5x12mm	4
8	109685	Pump Body	1
9	109686	Rear Bearing Plate	1
10	109689	Gear.	2
11	109687	Drive Shaft	1
12	109688	Driven Shaft	1
13	069X160	Shaft Seal Retainer	1
14	001U002	Dow Corning 112 Lubricant (not shown)	A/R*

A/R* = As required

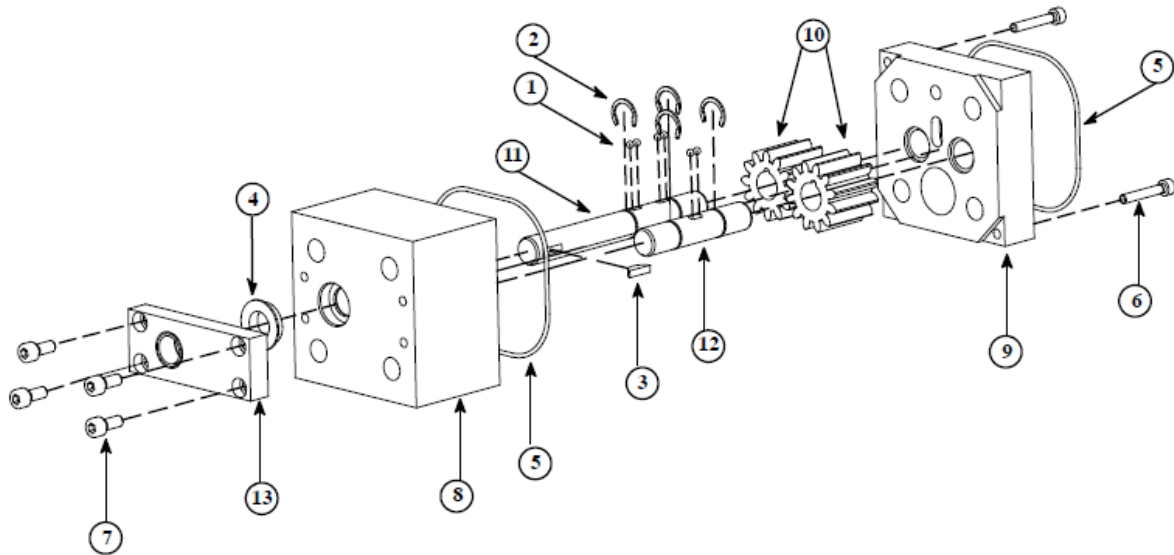

10.8.6 Single Gear Pump Assembly 0.15 cc/rev., PN 111253

Item No.	Part Number	Description	Quantity
1	018X031	Ball Bearing, 1/8 Diameter	6
2	078F017	Snap Ring, 1/2"	4
3	078I001	Key Woodruf	1
4	069X061	Shaft Seal	1
5	069X064	O-ring 041, Pump Seal	2
6	100908	Screw M4x25mm	2
7	101626	Screw M5x12mm	4
8	111251	Front Plate	1
9	100865	Rear Bearing Plate	1
10	111250	Drive Gear	2
11	012D079	Drive Shaft	1
12	012D080	Driven Shaft	1
13	069X160	Shaft Seal Retainer	1
14	001U002	Dow Corning 112 Lubricant (not shown)	A/R*

A/R* = As required

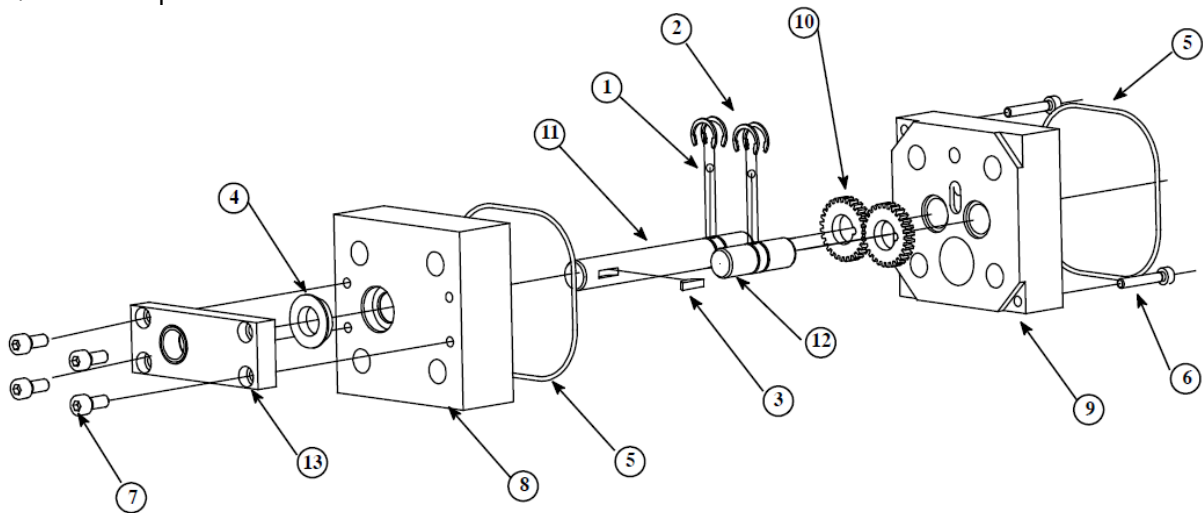

10.8.7 Dual Gear Pump Assembly 0.15 cc/rev., PN 111254

Item No.	Part Number	Description	Quantity
1	018X031	Ball Bearing, 1/8 Diameter	6
2	078F017	Snap Ring, 1/2"	4
3	078I001	Key Woodruf	1
4	069X061	Shaft Seal	1
5	069X064	O-ring 041, Pump Seal	2
6	101692	Screw M4x35mm	2
7	101626	Screw M5x12mm	4
8	111251	Front Plate	1
9	100865	Rear Bearing Plate	1
10	111252	Plate, middle gear	1
11	N00198	O-ring 113	2
12	111250	Gear	4
13	012D083	Drive Shaft	1
14	012D082	Driven Shaft	1
15	069X160	Shaft Seal Retainer	1
16	N00198	O-ring 113	2
17	001U002	Dow Corning 112 Lubricant (not shown)	A/R*

A/R* = As required

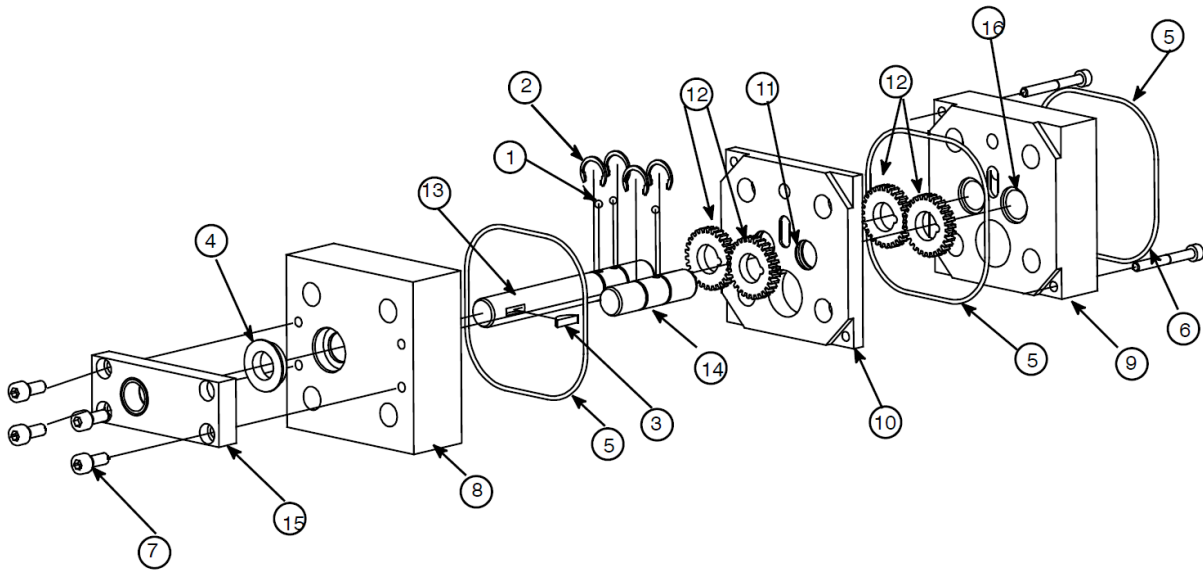

10.8 8 Single Gear Pump Assembly 0.55 cc/rev., PN 109908

Item No.	Part Number	Description	Quantity
1	018X031	Ball Bearing, 1/8 Diameter	6
2	078F017	Snap Ring, 1/2"	4
3	078I001	Key Woodruf	1
4	069X061	Shaft Seal	1
5	069X064	O-ring 041, Pump Seal	2
6	100908	Screw M4x25mm	2
7	101626	Screw M5x12mm	4
8	109906	Front Plate	1
9	100865	Rear Bearing Plate	1
10	109907	Gear	2
11	012D079	Drive Shaft	1
12	012D080	Driven Shaft	1
13	069X160	Shaft Seal Retainer	1
14	001U002	Dow Corning 112 Lubricant (not shown)	A/R*

A/R* = As required

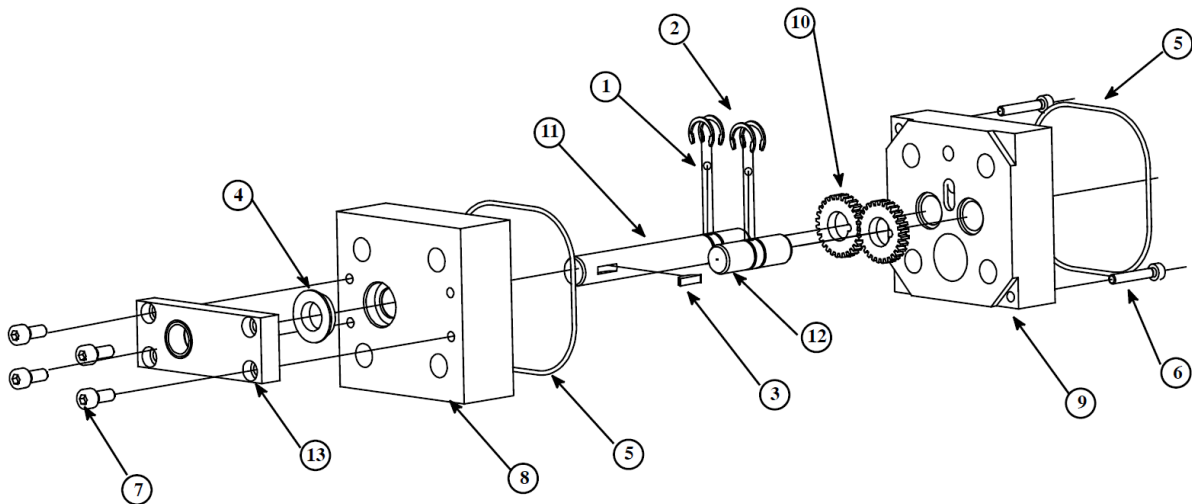

10.8.9 Dual Gear Pump Assembly 0.55 cc/rev., PN 109909

Item No.	Part Number	Description	Quantity
1	018X031	Ball Bearing, 1/8 Diameter	6
2	078F017	Snap Ring, 1/2"	4
3	078I001	Key Woodruf	1
4	069X061	Shaft Seal	1
5	069X064	O-ring 041, Pump Seal	2
6	101692	Screw M4x35mm	2
7	101626	Screw M5x12mm	4
8	109906	Front Plate	1
9	100865	Rear Bearing Plate	1
10	109905	Plate, middle gear	1
11	N00198	O-ring 113	2
12	109907	Gear	2
13	012D083	Drive Shaft	1
14	012D082	Driven Shaft,	1
15	069X160	Shaft Seal Retainer	1
16	001U002	Dow Corning 112 Lubricant (not shown)	A/R*

A/R* = As required

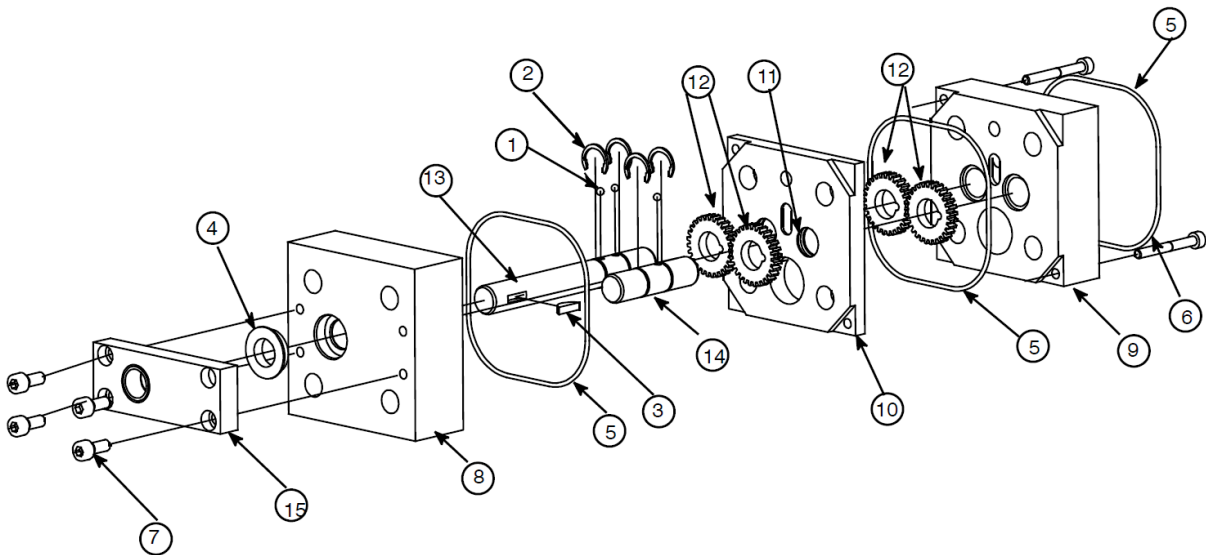

10.8.10 Single Gear Pump Assembly 20 cc/rev., PN 109694

Item No.	Part Number	Description	Quantity
1	109691	Pump Body	1
2	109692	Rear Bearing Plate	1
3	109693	Gear	2
4	109688	Driven Shaft	1
5	109687	Drive Shaft	1
6	018X031	Ball Bearing, 1/8 Dia.	6
7	078F017	Snap Ring, External, 1/2"	4
8	078I001	Key Woodruff	1
9	069X061	Seal Shaft	1
10	069X160	Shaft Seal Retainer	1
11	069X225	O-ring 042	1
12	069X064	O-ring 041	1
13	101626	Screw M5x12mm	4
14	102447	Screw M5x25mm	3
15	001U002	Dow Corning 112 Lubricant (not shown)	A/R*

A/R* = As required

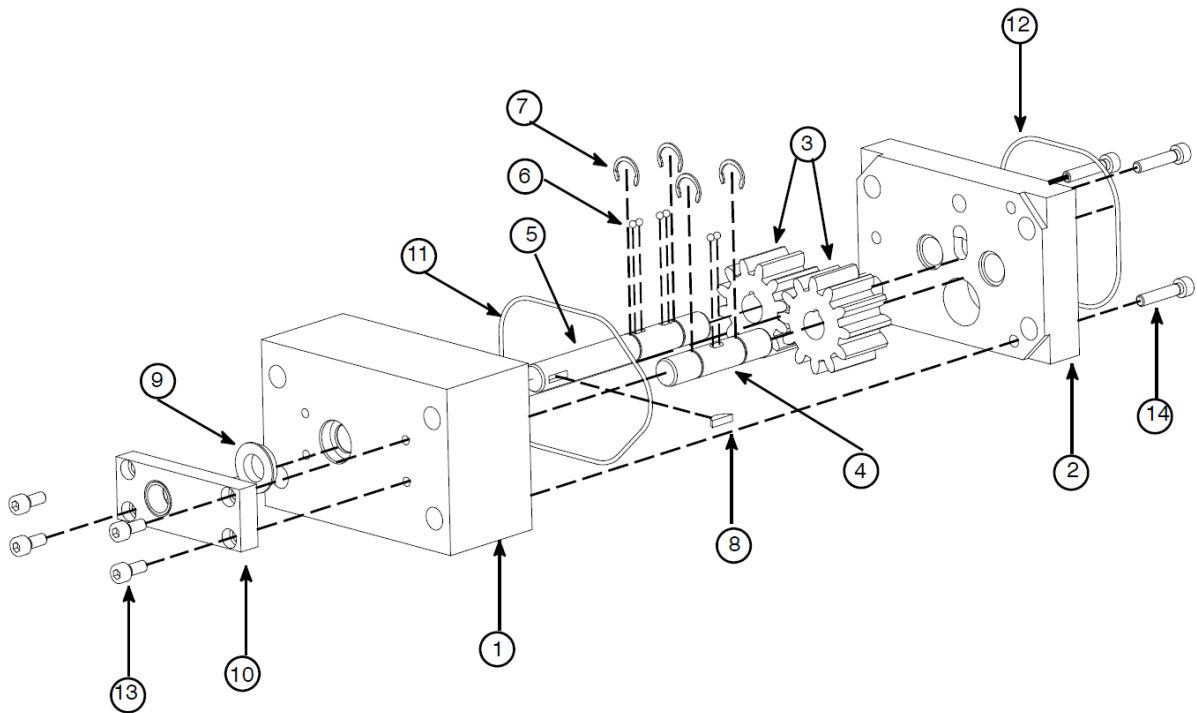

10.8.11 Pump Adapter Kit, ZN/TSHA Pump, PN 084E406

Item	Part Number	Description	Quantity
1	012G024	Pump Adapter	1
2	069X058	O-ring 028	1
3	N00179	O-ring 012	2
4	069X274	Seal between dual pump and hopper (not part of this assembly)	1
5	N00190	O-ring 024	1
6	078C130	Washer 3/8, 3/4 OD	1
7	-	Screw M10x85mm	4
8	-	Pump (see your BOM)	1

TSHA = Tool Steel High Accuracy.

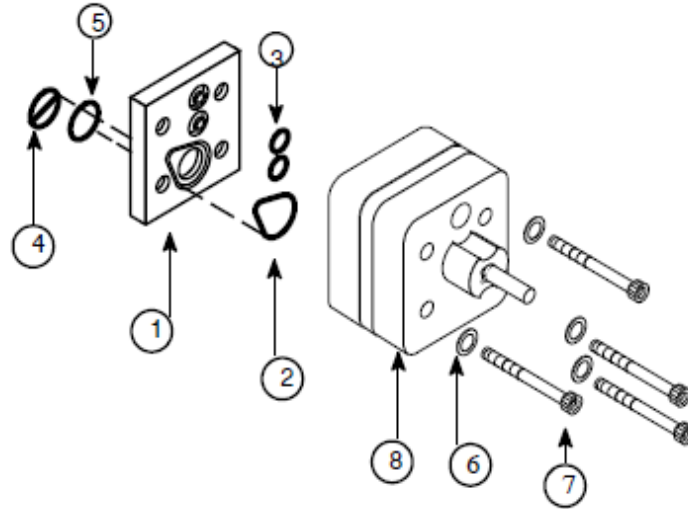

10.8.12 Pump Adapter Kit, Zenith-Pump PN 084E419

Item	Part Number	Description	Quantity
9	012G027	Pump Adapter Zenith	1
10	069X064	O-ring 041	1
11	N01010	O-ring 021	1
12	069X270	O-ring 025	2
13	801561	Screw 7/16-14 x 4	4
14	078C141	Washer 7/16, 3/4 OD	4
15	808680	Drive Shaft Seal (shown for reference only)	1
16	-	Pump (see your BOM)	1

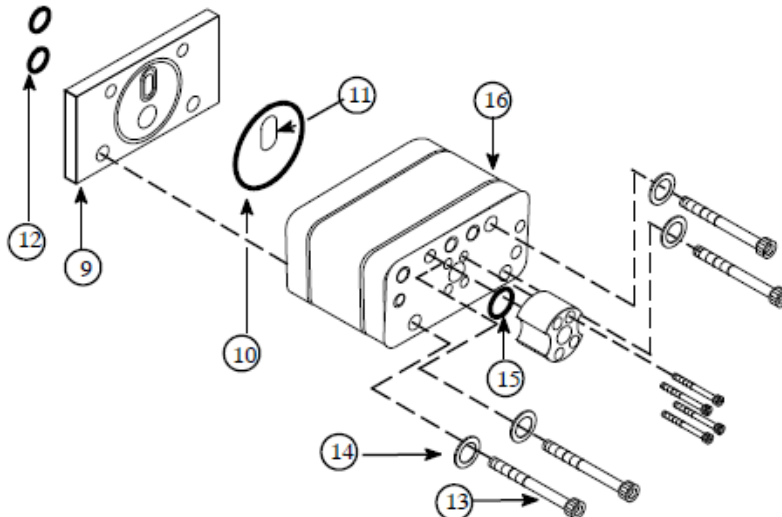

10.8.13 Pump Adapter Kit 20cc/rev., PN 816067

Item	Part Number	Description	Quantity
01	816068	Adapter plate	1
02	805878	Screw M12x30mm	4
03	N00188	O-ring 022	1
04	069X274	Seal between dual pump and hopper	1
05	069X064	O-ring 041	1
06	104777	Screw M10x90mm	4

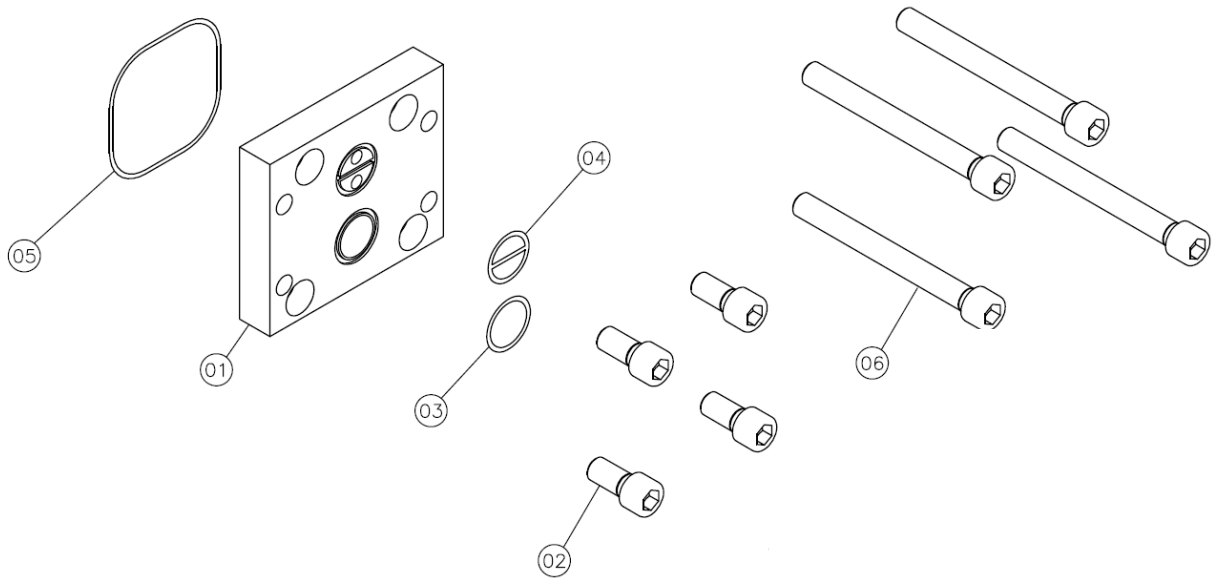

10.9 Pressure Gauge Kit (optional), PN 101175

Item	Part Number	Description	Quantity
1	101174	Pressure gauge / seal, 1000 psi (68 bar)	1
2	103330	Fitting, adaptor, G1/4X1/4NPT,ST	1
3	105914	Fitting, adaptor, 3/8 BSPX1/4NP	1
4	104325	Fitting, adaptor, SWL,6JX1/4MPT	1
5	101624	Fitting, adaptor, G1/4X06,STL	1
6	103623	Fitting, adaptor, G3/8X06,STL	1
7	N07830	Swivel Fitting, DN8 90°, 06FJX06MJ,STL	1
8	102987	Cuff, filter insulating	1
9	101248	Label, Warning pressure gauge (not shown)	1
10	N07054	Corrugated box, 4X4X8 (not shown)	1
11	N07831	Swivel Fitting, DN8 45°, #6 male x #6 female	1

Quick disconnection to JIC hose fitting capability

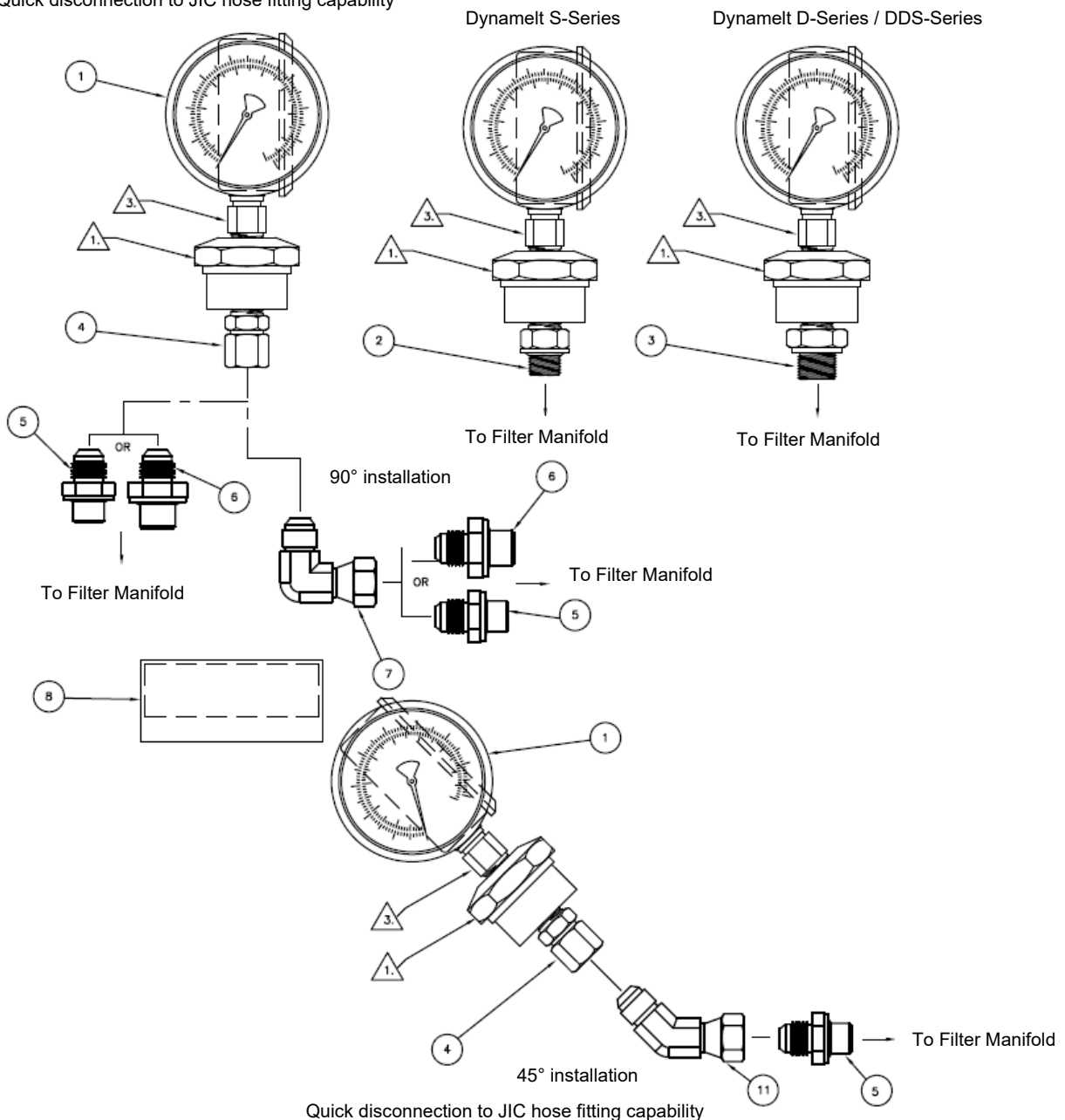

10.10 Heater Control Groups, PN 103571, 103572, 103573, 103574

- PN 103571 Heater Control Group 240V, 1 block
- PN 103572 Heater Control Group 240V, 2 blocks
- PN 103573 Heater Control Group 240V, 3 blocks
- PN 103574 Heater Control Group 240V, 4 blocks

Item	Part Number	Description	Quantity
1	036A170	Heater, 5/8 x 5", 240V, 500W (used in PN 103571)	1
	036A079	Heater, 5/8 x 10", 240V, 1000W (used in PN 103572)	1
	102149	Heater, 5/8 x 15", 240V, 1500W (used in PN 103573)	1
	036A077	Heater, 5/8 x 20", 240V, 2000W (used in PN 103574t)	1
2	106174	Sensor adapter (used in PN 103571 & 103572)	1
	036E032	Sensor adapter (used in PN 103573 & 103574)	1
3	N07958	Temperature sensor RTD, PT100, Ø 0.1875x1.25" (Ø 0.48x3.18cm), leads 48" (122cm) (used in PN 103571 & 103572)	1
	036B103	Temperature sensor RTD, PT100, Ø 0.1875x1.25" (Ø 0.48x3.18cm), leads 24" (61cm) (used in PN 103573 & 103574)	1
4	107754	Cover	1
5	107645	Conduit, 10"	1
6	106156	Screw M4 x 6mm	1
7	104163	Screw M6 x 25mm	2
8	107751	Fitting 5/16, conduct 9/16-18 (located in junction box)	1
9	N06883	Jam Nut (located in junction box)	1
10	103570	Set screw M5 x 8 x 6mm	1

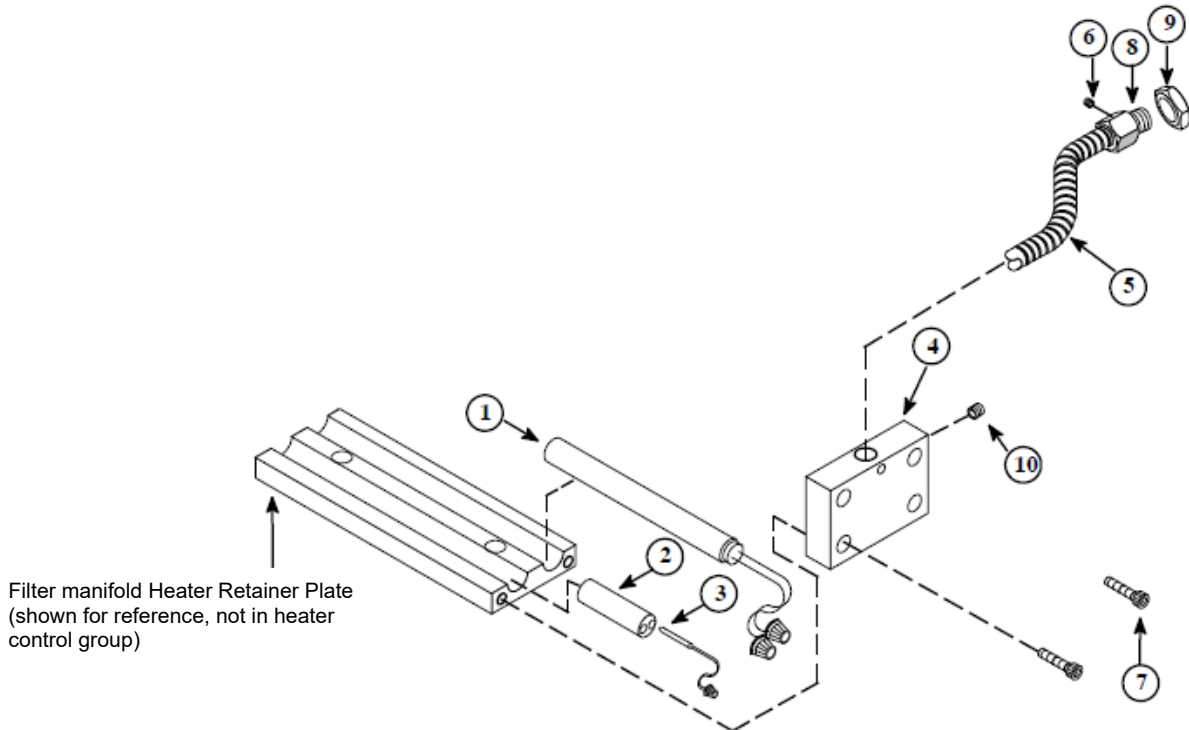

10.11 Transducer Assembly (Optional), PN 814521

Item	Part Number	Description	Quantity
1	811475	Pressure transducer 4-20 1/4 BSPP	1
2	113827	Bracket	1
3	N00182	O-ring 015	1
4	042X158	Cable	1
5	048J184	Cord grip 1/8" auf 1/4"	1
6	048J051	Lock nut 1/2"	1
7	078C021	Spacer 0,88 x 1,0 x 0,13	1
8	048J018	Plastic bushing cap	1

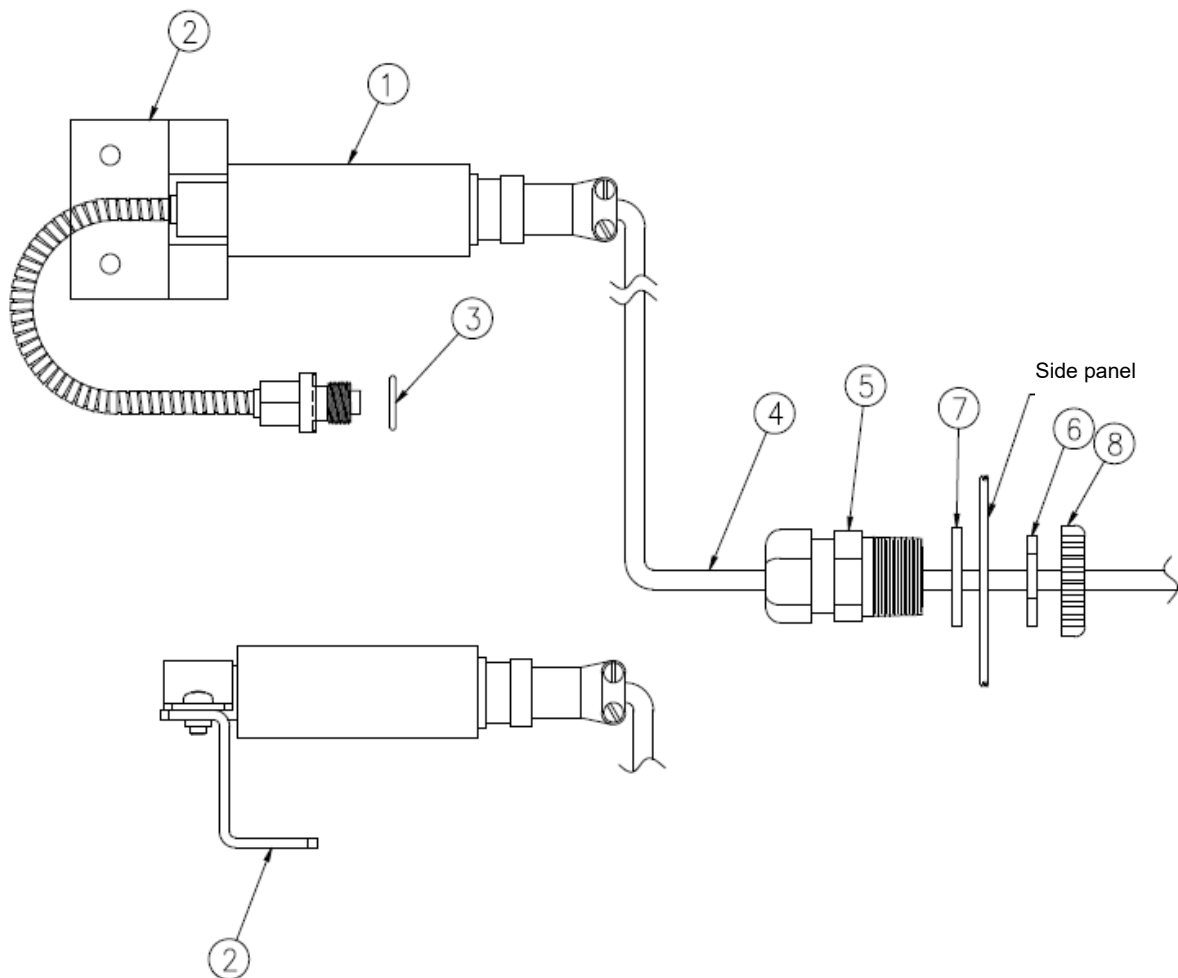

10.12 V6 Ramp Compensation Kits

10.12.1 2-Solenoids-Kit for V6 Ramp Compensation (Optional), PN 821610

Item	Part Number	Description	Quantity
1	030A049	Solenoid 3-way, 1/8NPT, 24VDC	2
2	078A157	Screw M8 32x1	4
3	N06436	Elbow fitting 1/4 tube x 1/8 NPT	4
4	102446	Screw M4 - 0,70 x 10	2
5	821609	Bracket, for 2 solenoids, V6	1
6	030B108	Fitting, breather vent, 1/8NPT	2
*	100380	Coalescing Filter/Regulator assembly	1
*	116389	Fitting, BHD, UN, 1/4NPT FE, NPB	1
*	817808	Fitting, BRANCH EL, 1/4 TUB X 1/4 MPT	1
*	N00712	Hex nut 1/4-20	2
*	N00724	Hex screw 1/4-20 X .75	2
*	N06502	Elbow fitting 1/4MPTX3/8 tube	2
*	N06504	Fitting, union Tee, 1/4 tube	2
*	N07677	Tubing Tee, .25 OD X.125I	15

* not shown.

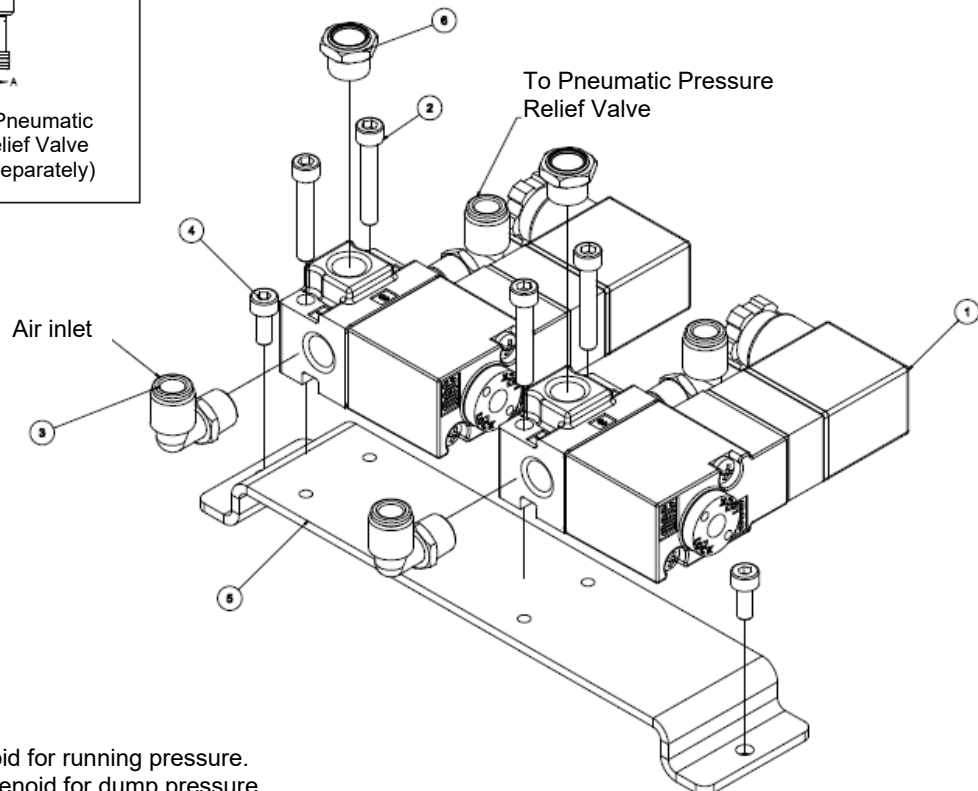
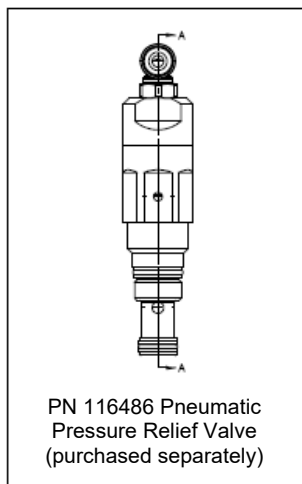

NOTE:

Energize solenoid for running pressure.
De-energize solenoid for dump pressure.

10.12.2 4-Solenoids-Kit for V6 Ramp Compensation (Optional), PN 821640

Item	Part Number	Description	Quantity
1	030A049	Solenoid, 3-way, 1/8NPT, 24VDC	4
2	078A157	Screw 8-32 X 1	8
3	N06436	Elbow fitting, 1/4tube X 1/8NPT	8
4	102446	Screw, M4-0.70X10	2
5	821639	Bracket, 6-solenoid, Melter, V6	1
6	030B108	Fitting, breather vent, 1/8NPT	4
*	100380	Filter/Regulator assembly, coalescing	1
*	114033	Tubing, 3/8"	5
*	116389	Fitting, BHD, UN, 1/4NPT FE, NPB	1
*	817694	Fitting, DBL branch EL, 1/4 TUB X 1/4MPT	1
*	N00712	Hex nut, 1/4-20	2
*	N00724	Hex Screw, HD, 1/4-20 X .75	2
*	N06502	Fitting, EL, 1/4MPTX3/8tube	2
*	N06504	Fitting T-union, 1/4 tube	4
*	N07677	Tubing, TFE, .25 OD X.125I	20

* not shown.

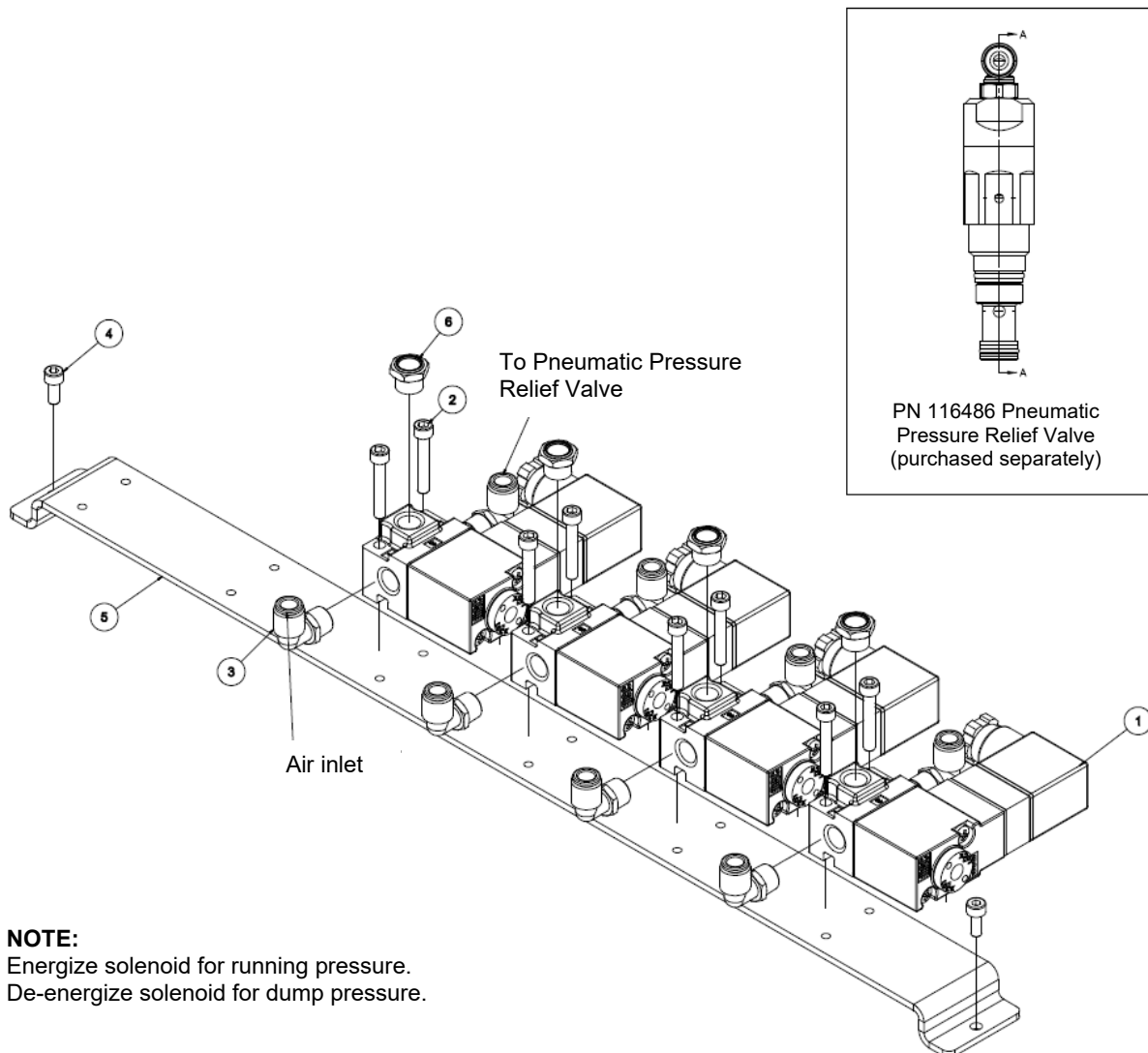

NOTE:
Energize solenoid for running pressure.
De-energize solenoid for dump pressure.

10.12.3 6-Solenoids-Kit for V6 Ramp Compensation (Optional), PN 821642

Item	Part Number	Description	Quantity
1	030A049	Solenoid, 3-way, 1/8NPT, 24VDC	6
2	078A157	Screw 8-32 X 1	12
3	N06436	Elbow fitting, 1/4tube X 1/8NPT	12
4	102446	Screw, M4-0.70X10	2
5	821639	Bracket, 6-solenoid, Melter, V6	1
6	030B108	Fitting, breather vent, 1/8NPT	6
*	100380	Filter/Regulator assembly, coalescing	1
*	114033	Tubing, 3/8"	5
*	116389	Fitting, BHD, UN, 1/4NPT FE, NPB	1
*	817694	Fitting, DBL branch EL, 1/4 TUB X 1/4MPT	1
*	N00712	Hex nut, 1/4-20	2
*	N00724	Hex Screw, HD, 1/4-20 X .75	2
*	N06502	Fitting, EL, 1/4MPTX3/8tube	2
*	N06504	Fitting T-union, 1/4 tube	4
*	N07677	Tubing, TFE, .25 OD X.125I	20

* not shown.

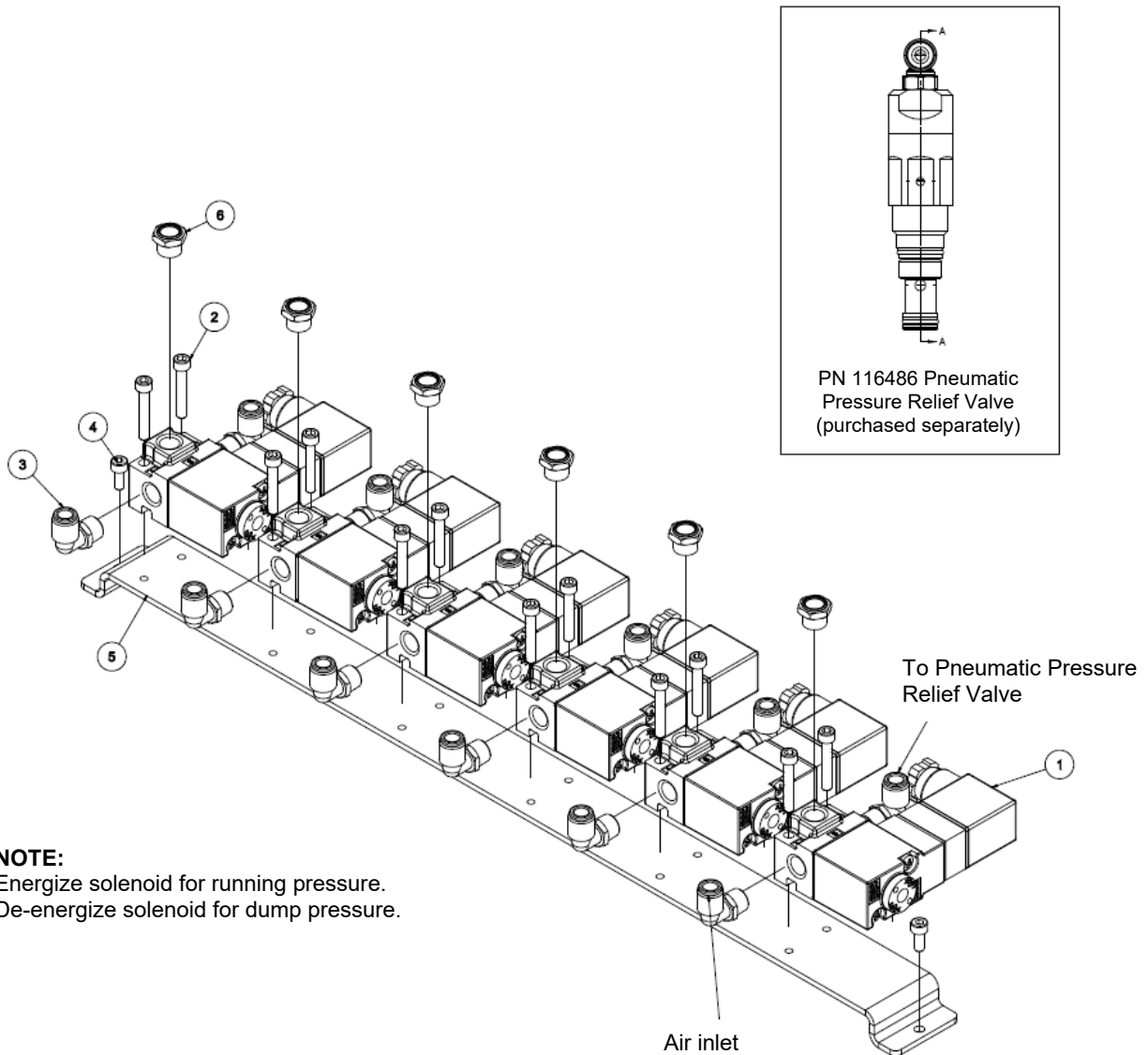

NOTE:
Energize solenoid for running pressure.
De-energize solenoid for dump pressure.

10.12.4 Mounting Dimensions for Solenoids-Kit

Example M70:

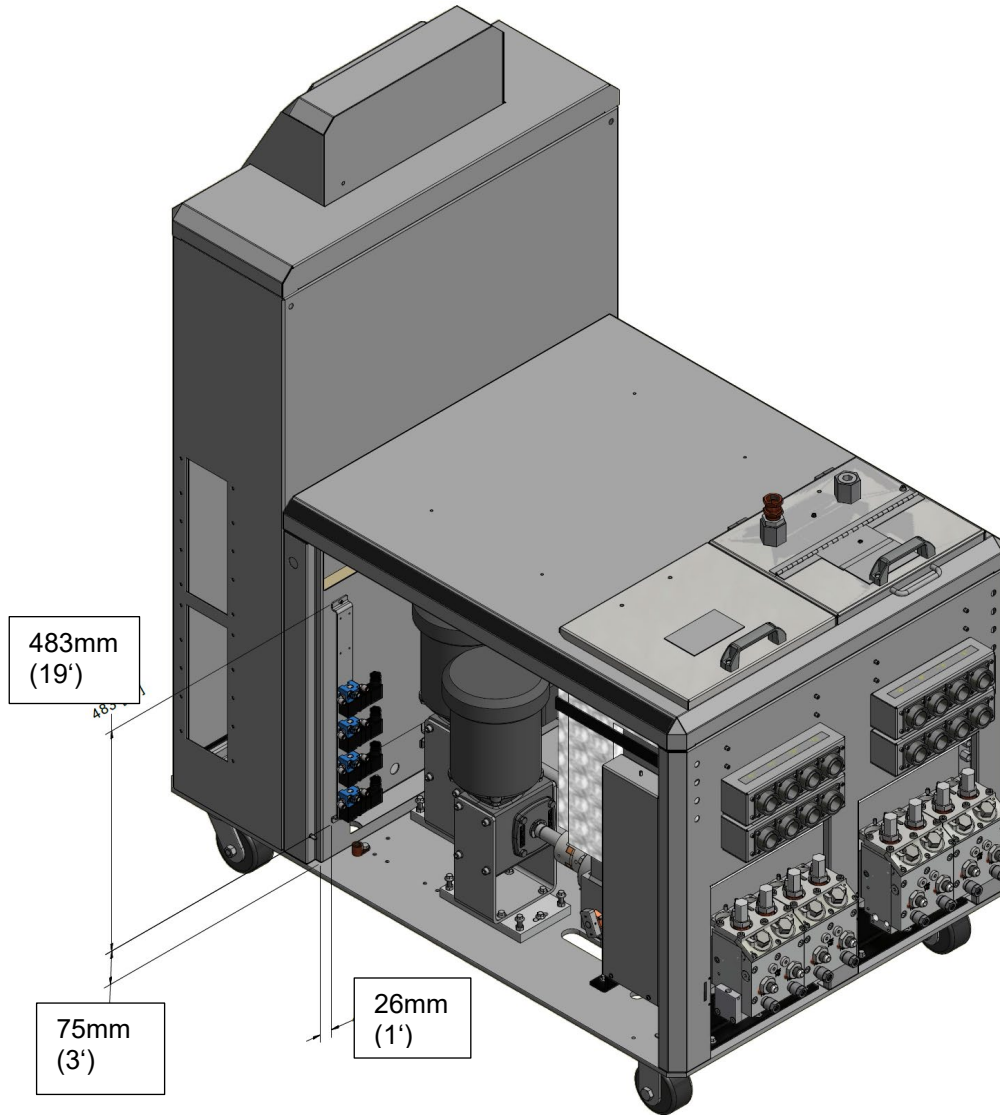

Example M140:

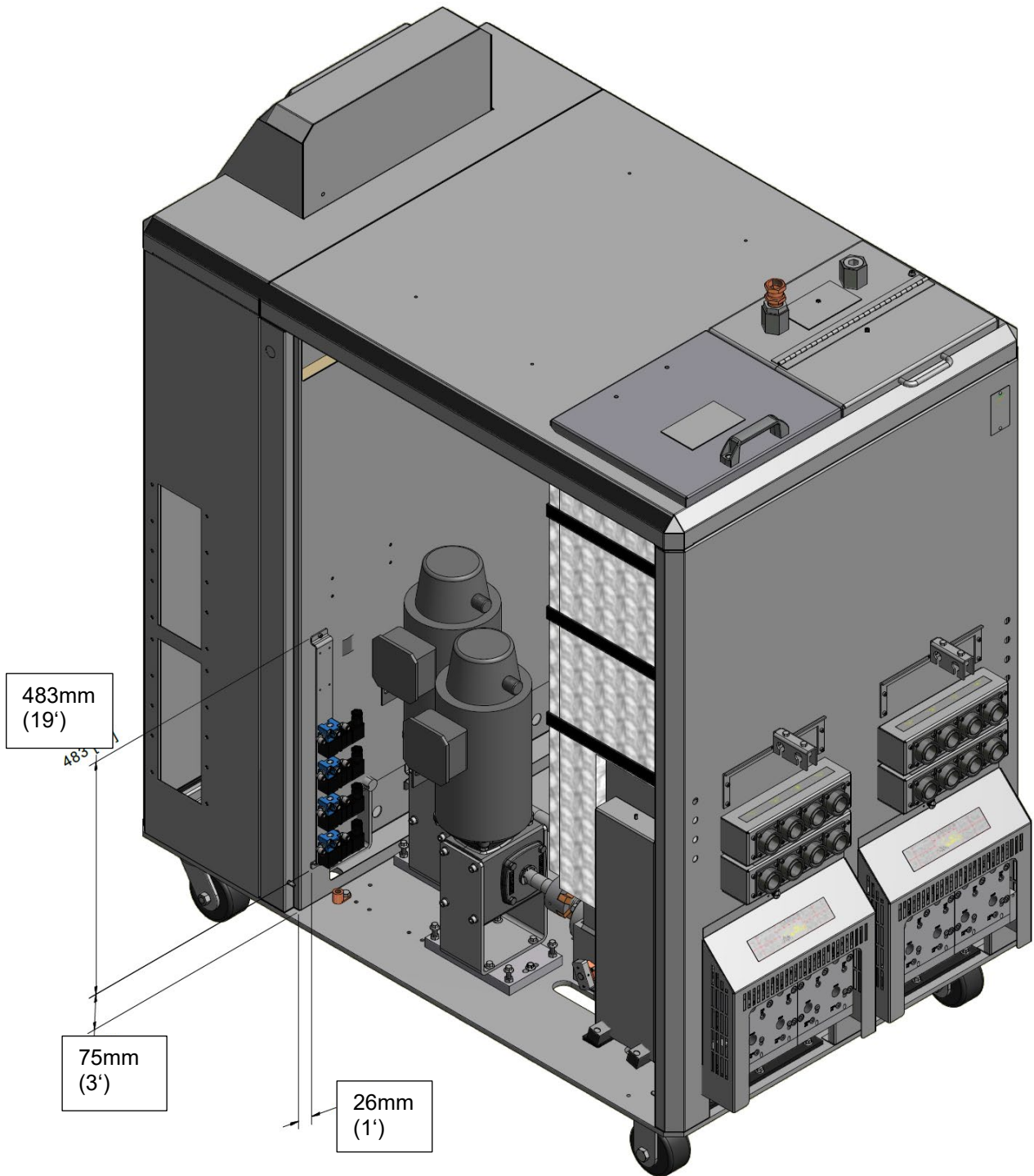

Chapter 11

Schematics & Engineering Drawings

11.1 Head Schematic, PN 103117, Rev.B, DynaControl

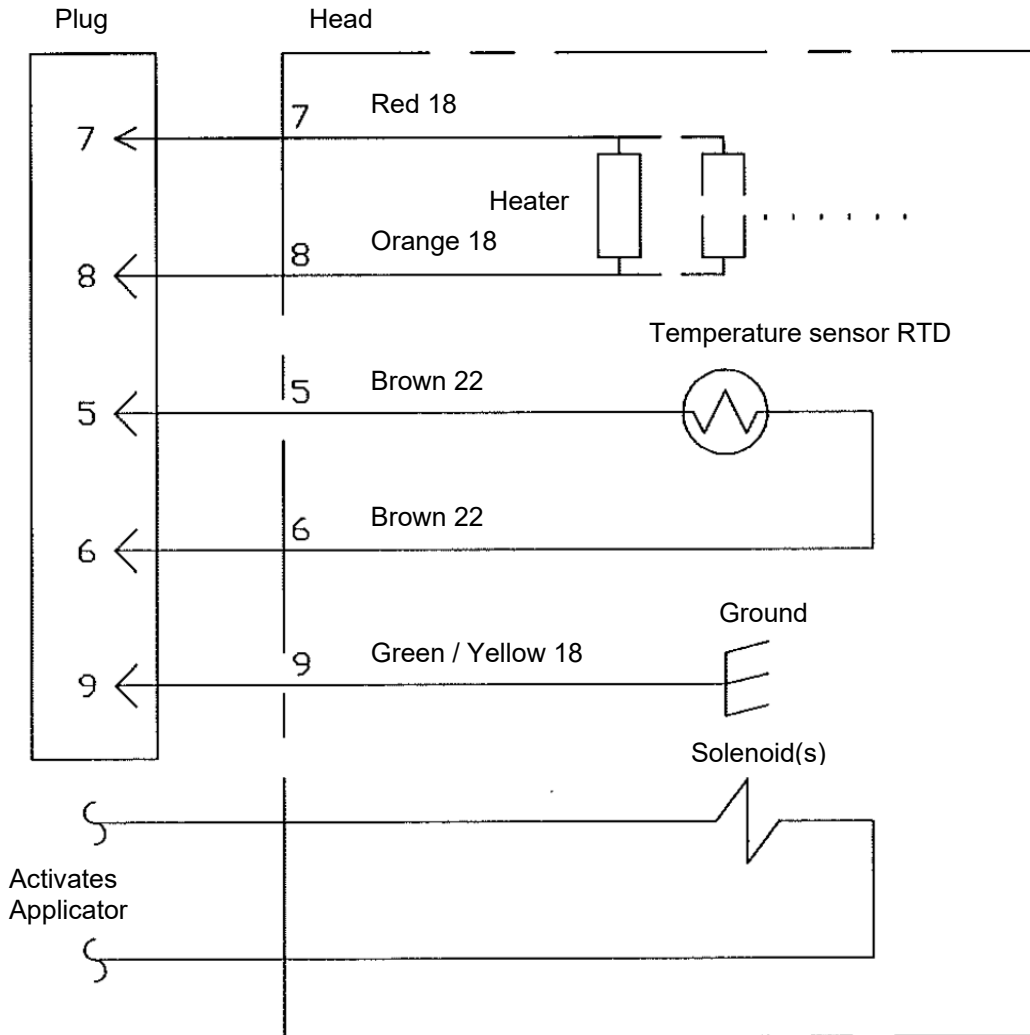

NOTES:

1. All wire MIL-W-22759/10 or 12, minimum 600 Volts, 260 °C.
2. Solenoid(s) voltage and timing method depends on application.
3. Temperature sensor RTD is 100 Ohm Platinum.

11.2 Hose Schematic, PN 101082, Rev.G, DynaControl

Melter to Applicator

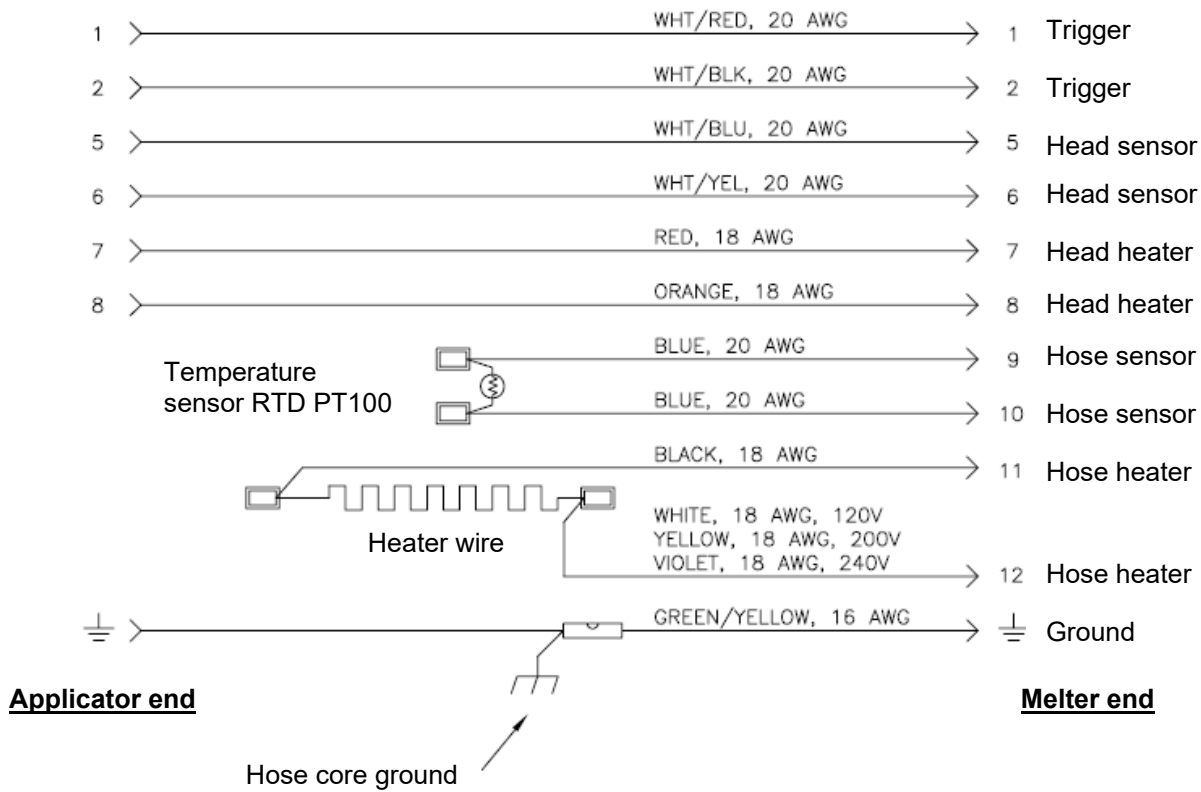

NOTES:

1. All wiring is routed through the hose.
2. Wire sizes shown are for no. 6 and no. 8 hoses up to 24 ft. in length.
For larger diameter and longer hoses, heater lead wires are 16 AWG.
Other wire sizes and colors may be changed in special hoses, per customer request.

11.3 Level Control Schematic PN 802972 REV.C

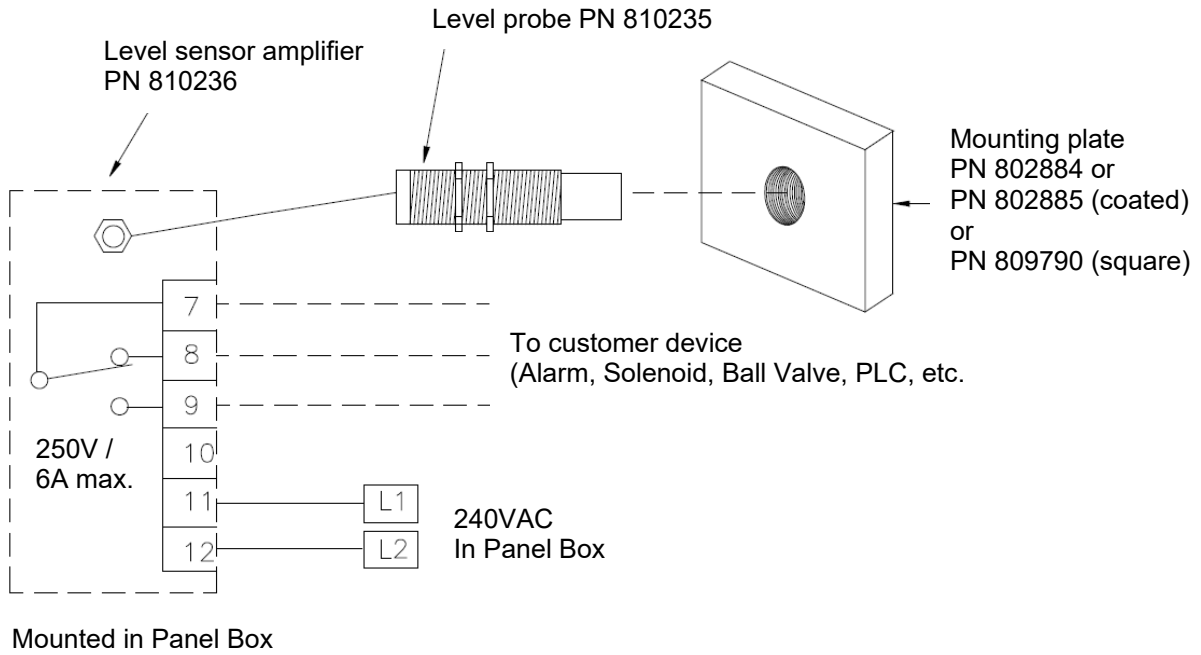

11.4 Typical Hydraulic Schematic

Single pump, Motor, Pneumatic Pressure Relief Valve, Filter, optional Transducer and optional Pressure Gauge

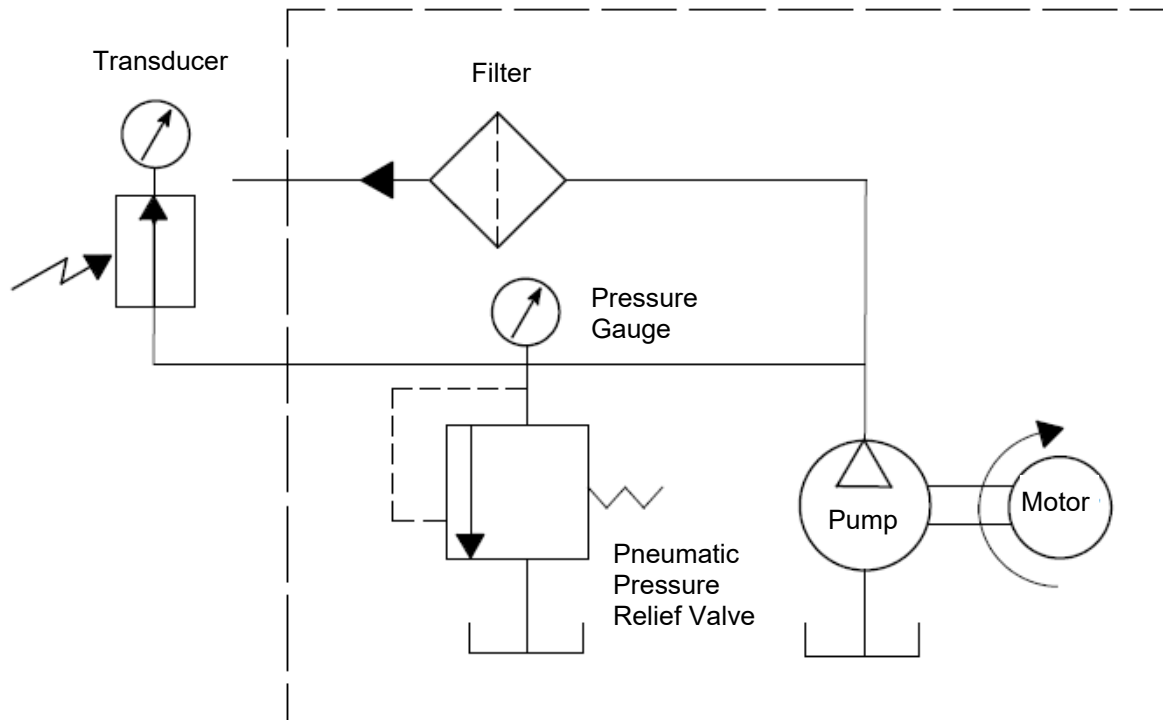

11.5 Grounding diagram, CE mark, PN 804704, Rev.E

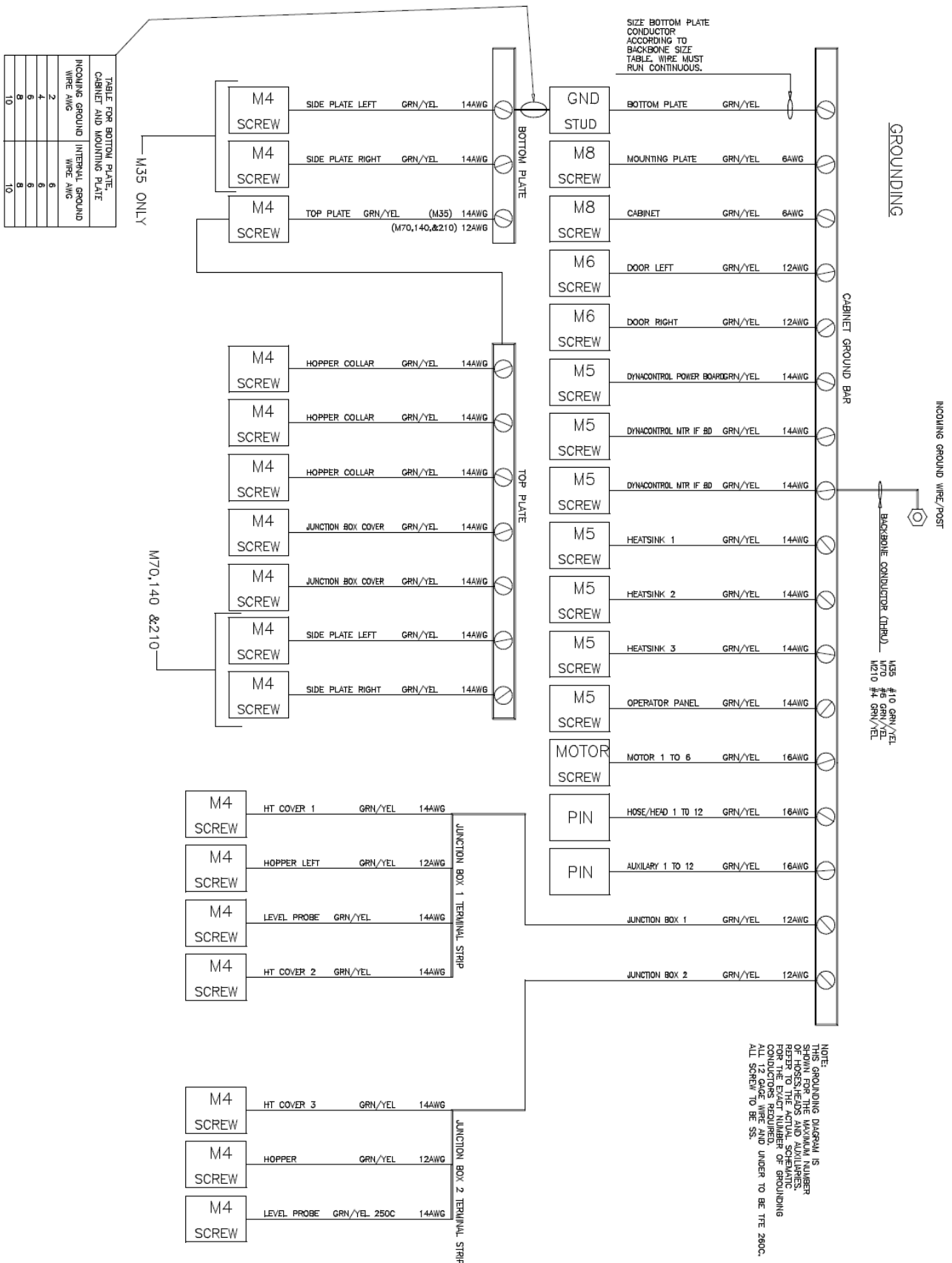

11.6 Schematics M210 V6 240V Single Hopper, PN 820863U

THIS DRAWING IS THE PROPERTY OF INVA/DYNATEC.
DO NOT REPRODUCE OR DISCLOSE TO
OTHERS WITHOUT EXPRESS WRITTEN
CONSENT OF INVA/DYNATEC.

REVISIONS					
REV.	BY	DESCRIPTION	DATE	BY	APPROVED
17050	L	CONVERTED TO ACADE	07.31.17	BFG	
ECN688	M	REMOVED SPIB WIRING STUB	09.11.17	BFG	
ECN702	N	CORRECTIONS PER ASSEMBLY	09.22.17	BFG	
18146	P	ADDED DRIVE DISCONNECT	11.26.18	BFG	
ECN576	D	ADD GND WIRE TO XF1 SECONDARY	09.27.19	DJT	
ECN822	R	REVISE SSR CABLE DETAIL (SHT 13/14/15)	02.24.20	DJT	
ECN849	S	CORRECT DV3 WIRING (SHT 9)	03.11.20	DJT	
ECN1239	T	ADD VOLTAGE TO XF1	03.11.21	JJB	
ECN1309	U	REVISE FLT1	05.17.21	JJB	

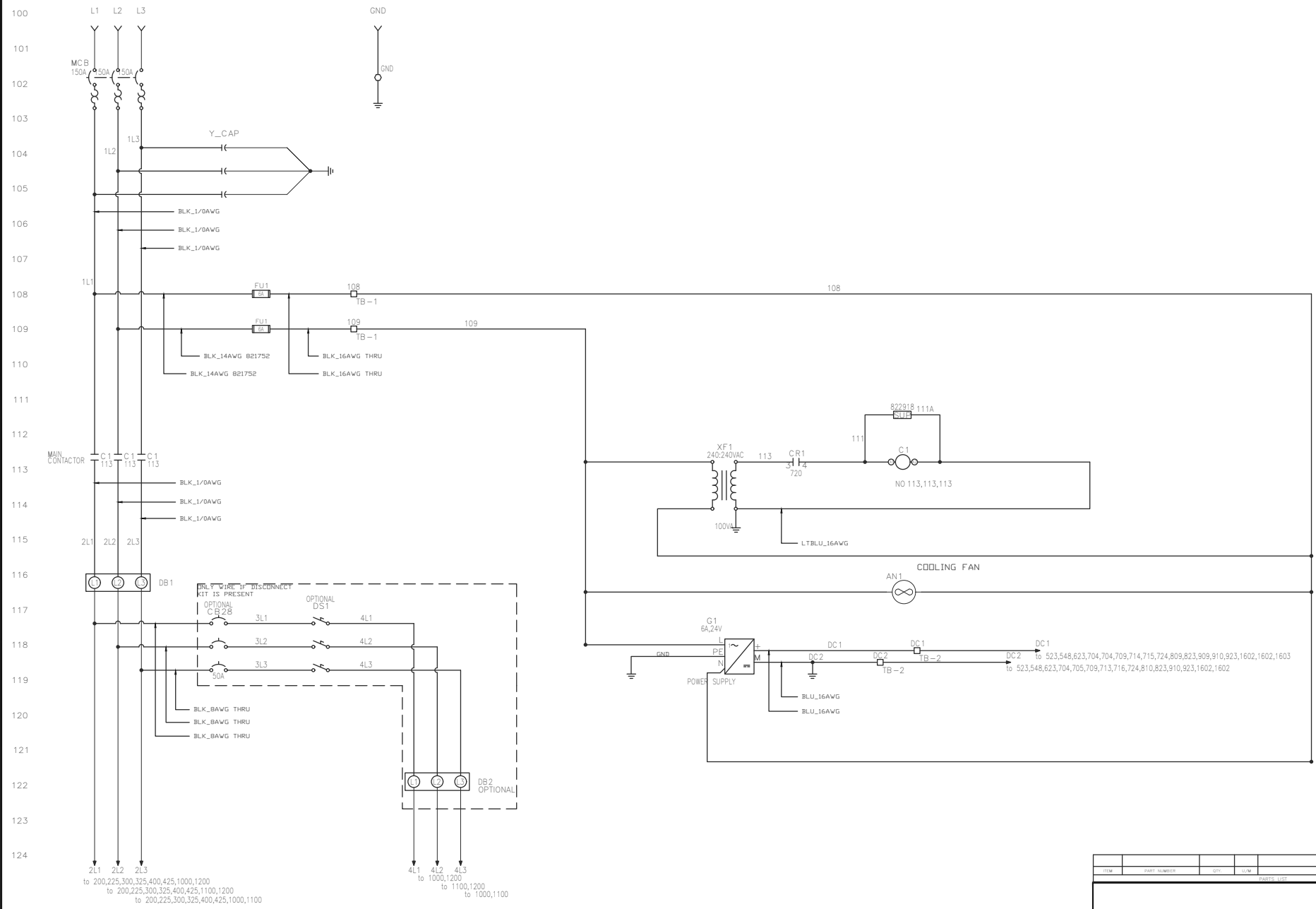

2L1 2L2 2L3
to 200,225,300,325,400,425,1000,1200
to 200,225,300,325,400,425,1100,1200
to 200,225,300,325,400,425,1000,1100

4L1 4L2 4L3
to 1000,1200
to 1100,1200
to 1000,1100

ITEM	PART NUMBER	QTY	UOM	DESCRIPTION																									
PARTS LIST																													
TOLERANCES (UNLESS OTHERWISE SPECIFIED)																													
<table border="1"> <tr> <td>U/M</td> <td>SEE</td> <td colspan="3">TITLE: V6, M210, 240V, SH</td> </tr> <tr> <td colspan="2">DO NOT SCALE DRAWING</td> <td colspan="3">POWER DISTRIBUTION</td> </tr> <tr> <td colspan="2">COMPUTER DESCRIPTIONS (CHARACTERS)</td> <td>STATUS</td> <td>ISS</td> <td>SCALE: BFG</td> </tr> <tr> <td colspan="2">NEXT ASSY</td> <td colspan="2">DRAWN BY: BFG</td> <td>CHECKED BY: ---</td> </tr> <tr> <td colspan="2">FOR MACHINING STANDARDS AND DIMENSIONS, SEE INV/DYNATEC SPEC. APPEND</td> <td>SOURCE</td> <td>DATE: 09.30.13</td> <td>APPROV BY: 820863</td> </tr> </table>					U/M	SEE	TITLE: V6, M210, 240V, SH			DO NOT SCALE DRAWING		POWER DISTRIBUTION			COMPUTER DESCRIPTIONS (CHARACTERS)		STATUS	ISS	SCALE: BFG	NEXT ASSY		DRAWN BY: BFG		CHECKED BY: ---	FOR MACHINING STANDARDS AND DIMENSIONS, SEE INV/DYNATEC SPEC. APPEND		SOURCE	DATE: 09.30.13	APPROV BY: 820863
U/M	SEE	TITLE: V6, M210, 240V, SH																											
DO NOT SCALE DRAWING		POWER DISTRIBUTION																											
COMPUTER DESCRIPTIONS (CHARACTERS)		STATUS	ISS	SCALE: BFG																									
NEXT ASSY		DRAWN BY: BFG		CHECKED BY: ---																									
FOR MACHINING STANDARDS AND DIMENSIONS, SEE INV/DYNATEC SPEC. APPEND		SOURCE	DATE: 09.30.13	APPROV BY: 820863																									
DATE: 09.30.13		SHEET 1 OF SHEETS 17		DRAWING NO: 820863																									

THIS DRAWING IS THE PROPERTY OF INV/DYNATEC.
DO NOT REPRODUCE OR DISCLOSE TO
OTHERS WITHOUT EXPRESS WRITTEN
CONSENT OF INV/DYNATEC.

REVISIONS					
REV.	BY	DESCRIPTION	DATE	BY	APPROVED

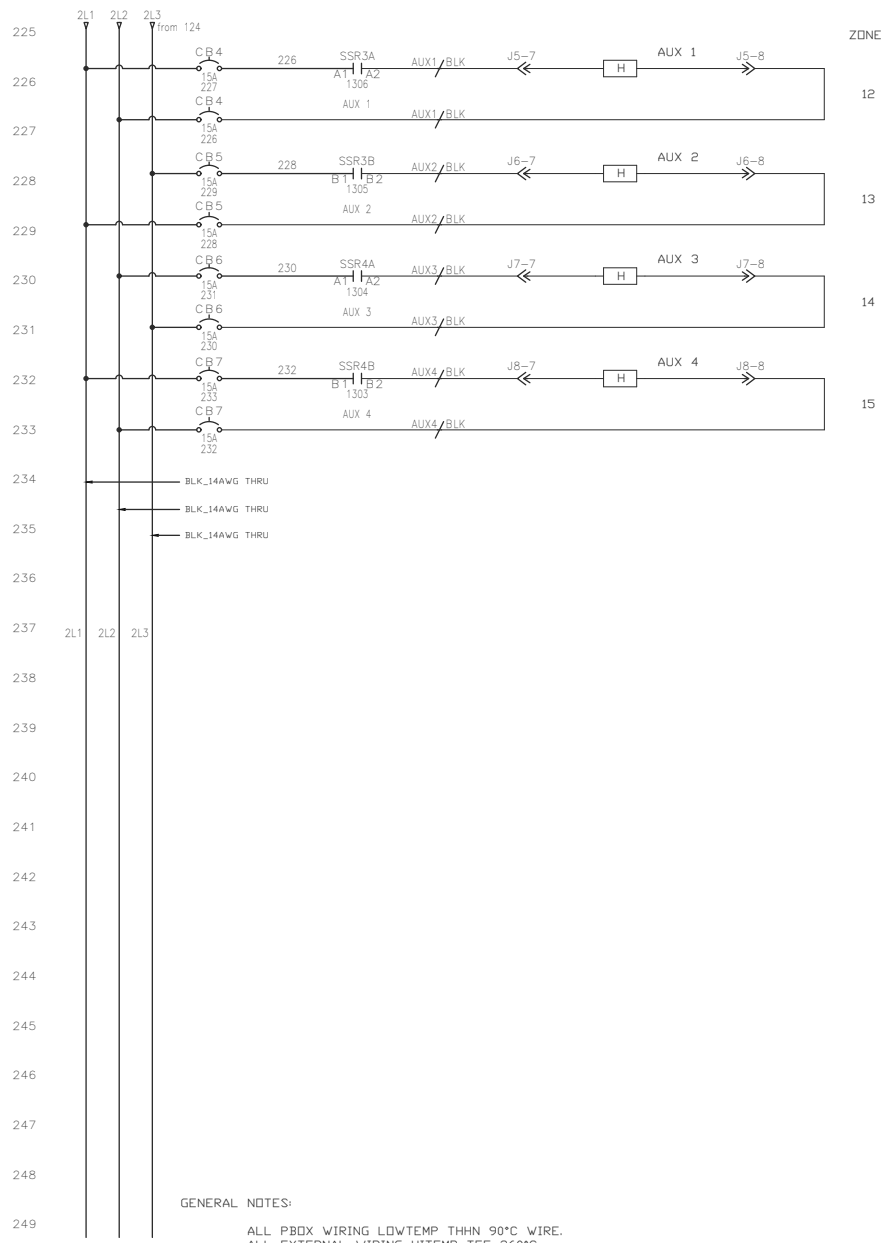
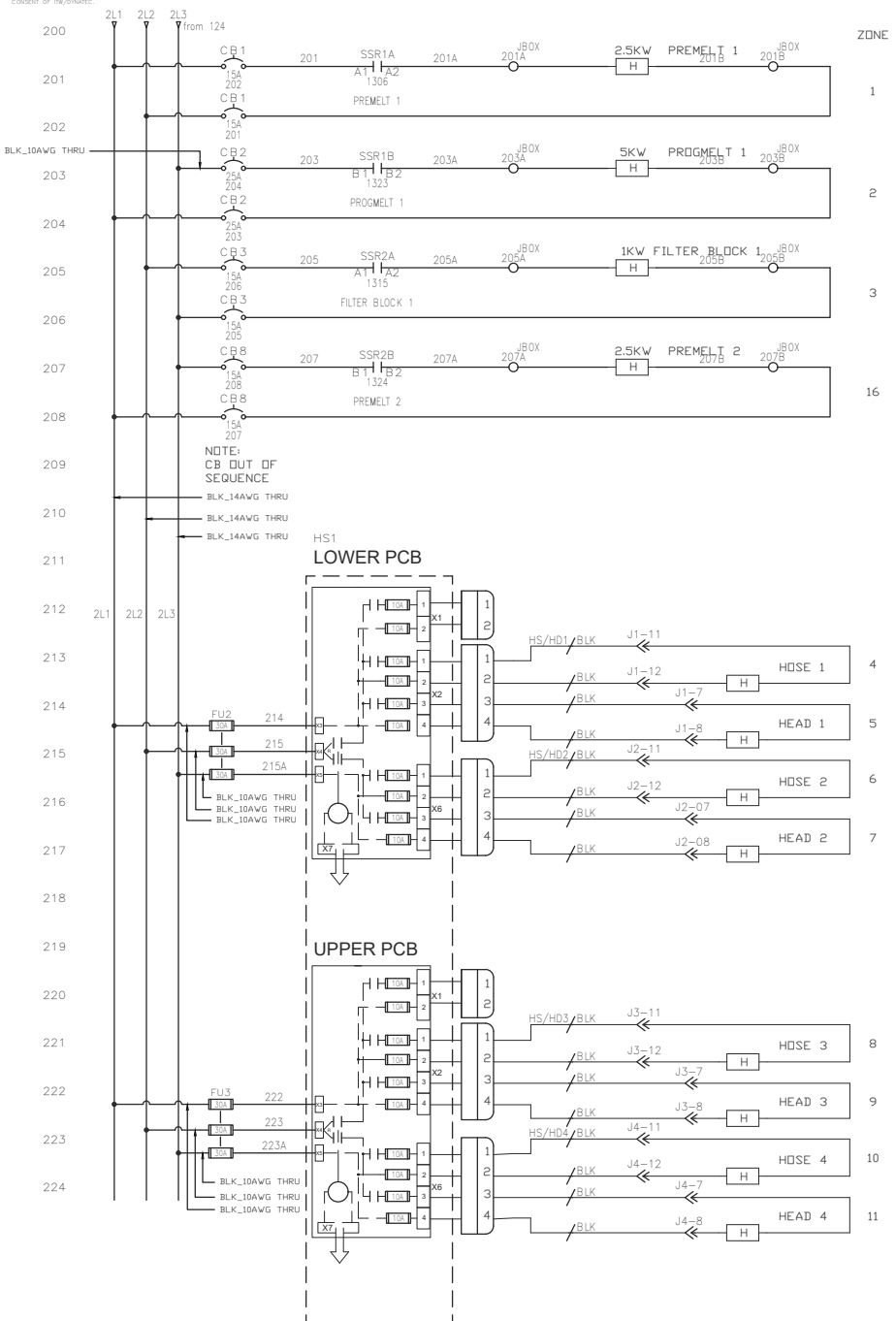

GENERAL NOTES:
 ALL PBOX WIRING LOWTEMP THHN 90°C WIRE.
 ALL EXTERNAL WIRING HITEMP TFE 260°C
 OR EQUIV.
 □ DENOTES TERMINAL IN PBOX
 ○ DENOTES TERMINAL IN JBOX
 — APPLY WIRE NUMBERS TO BOTH ENDS OF WIRE.
 — DENOTES DEVICE EXTERNAL TO PBOX.
 — WIRE ALL GROUND CONNECTIONS PER DRAWING
 804704.
 THIS IS A GENERAL SCHEMATIC. NOT ALL DEVICES
 MAY BE PRESENT. SEE ORDER FOR NUMBER
 OF HOSES, HEADS, AUX, AND MOTORS.

ITEM	PART NUMBER	QTY	UOM	DESCRIPTION
PARTS LIST				
TOLERANCES (UNLESS OTHERWISE SPECIFIED)				
DO NOT SCALE DRAWING		STATUS		DESIGN
COMPUTER DESCRIPTIONS (CHARACTERS)		NEXT ASSY		SCALE: DRAWN BY: CHECKED BY: APP'D BY:
FOR MACHINING STANDARDS AND DIMENSIONS, SEE INV/DYNATEC SPEC. A05030		SOURCE		DATE: 09.30.13 SHEET 2 OF SHEETS 17 DRAWING NO: 820863



TITLE: V6, M210, 240V, SH
HEATER CIRCUITS

THIS DRAWING IS THE PROPERTY OF INV/DYNATEC.
DO NOT REPRODUCE OR DISCLOSE TO
OTHERS WITHOUT EXPRESS WRITTEN
CONSENT OF INV/DYNATEC.

REVISIONS					
REV.	BY	DESCRIPTION	DATE	BY	APPROVED

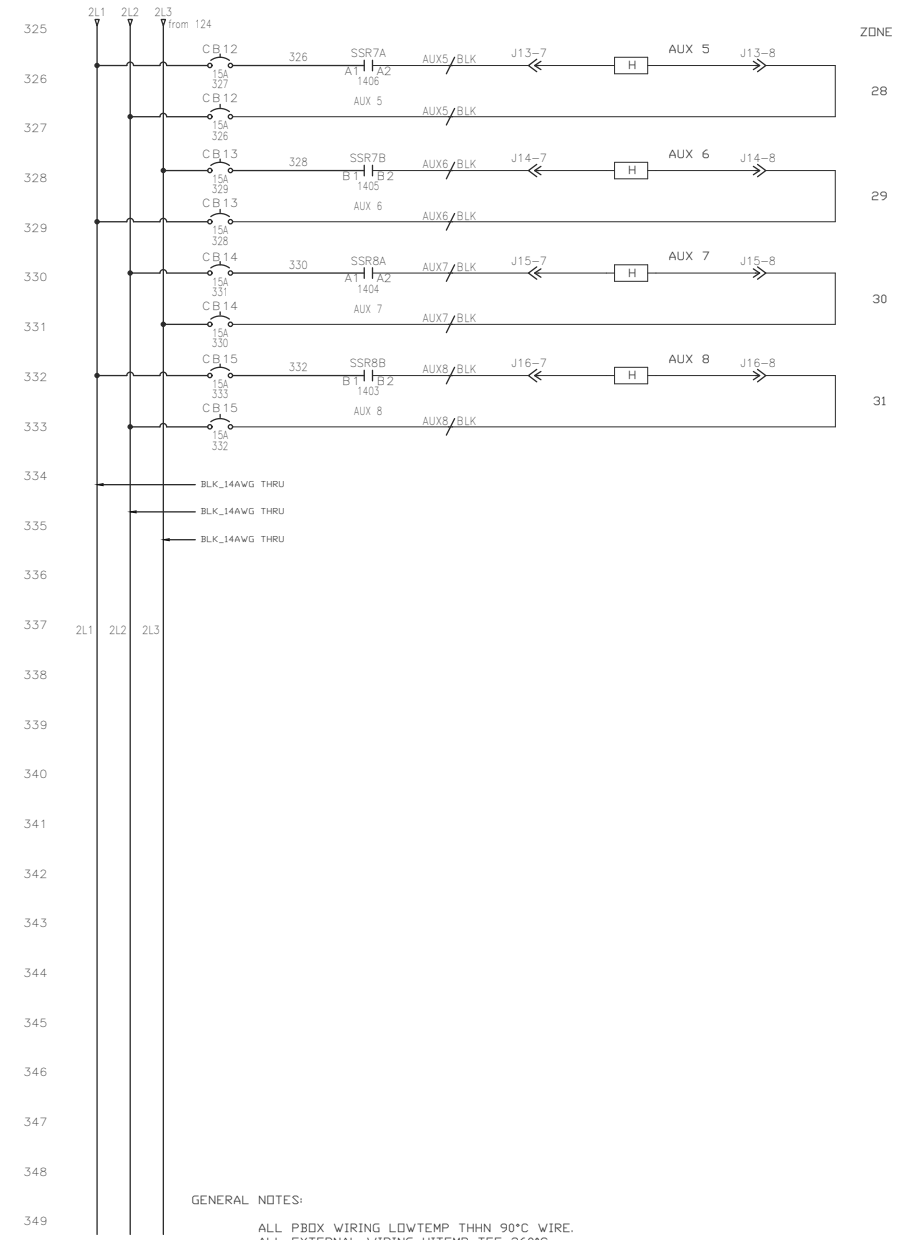
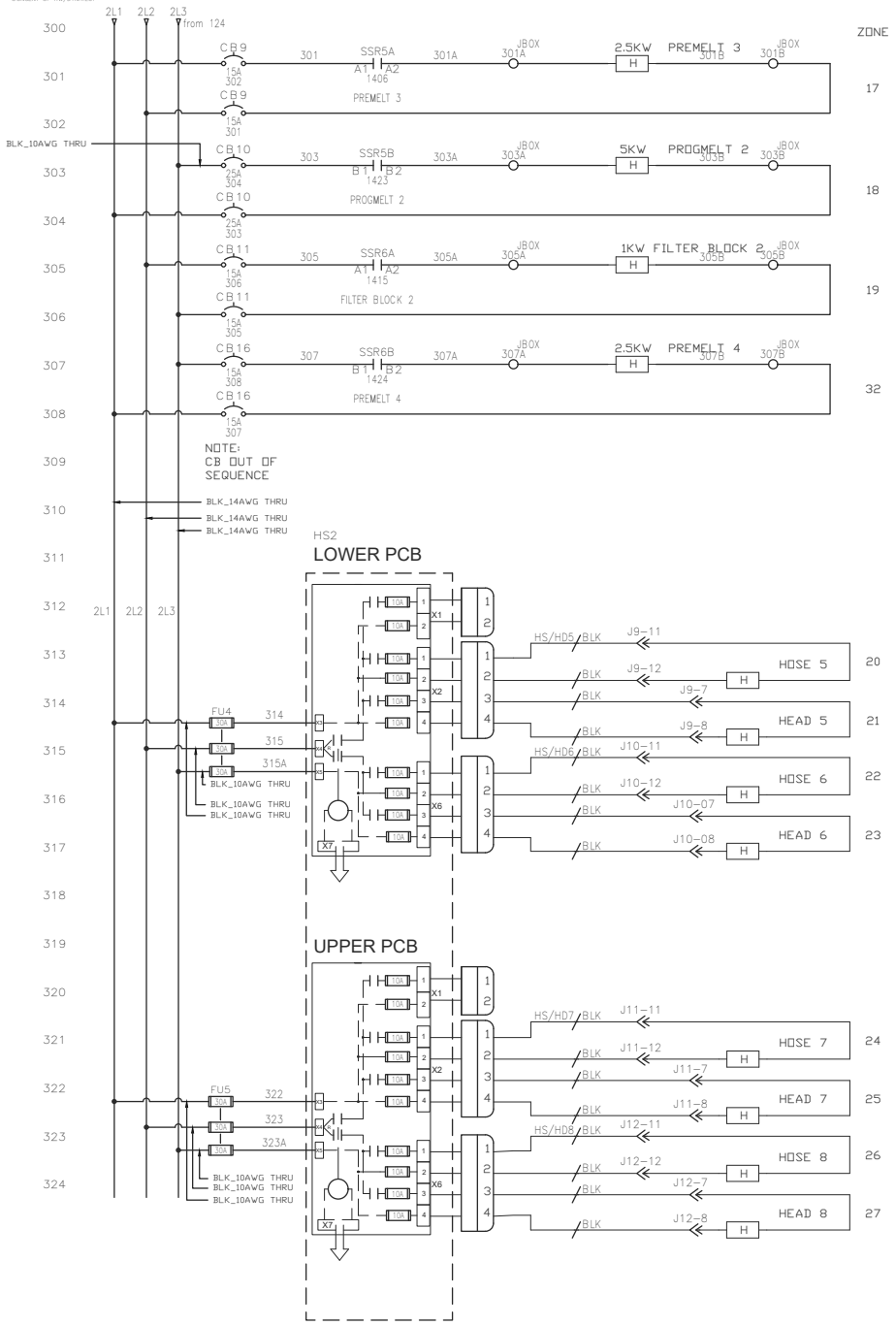

GENERAL NOTES:

- ALL PBOX WIRING LOWTEMP THHN 90°C WIRE.
- ALL EXTERNAL WIRING HITEMP TFE 260°C OR EQUIV.
- DENOTES TERMINAL IN PBOX
- DENOTES TERMINAL IN JBOX
- APPLY WIRE NUMBERS TO BOTH ENDS OF WIRE.
- DENOTES DEVICES EXTERNAL TO PBOX.
- WIRE ALL GROUND CONNECTIONS PER DRAWING 804704.
- THIS IS A GENERAL SCHEMATIC. NOT ALL DEVICES MAY BE PRESENT. SEE ORDER FOR NUMBER OF HOSES, HEADS, AUX, AND MOTORS.

ITEM	PART NUMBER	QTY	UOM	DESCRIPTION
PARTS LIST				
TOLERANCES (UNLESS OTHERWISE SPECIFIED)				
DO NOT SCALE DRAWING		STATUS		DESIGN
COMPUTER DESCRIPTIONS (CHARACTERS)		NEXT ASSY		SCALE: DRAWN BY: CHECKED BY: APP'D BY:
FOR MACHINING STANDARDS AND DIMENSIONS, SEE INV/DYNATEC SPEC. A05030		SOURCE		DATE: 09.30.13 SHEET 3 OF SHEETS 17 DRAWING NO: 820863



TITLE: V6, M210, 240V, SH HEATER CIRCUITS

THIS DRAWING IS THE PROPERTY OF IN/DMATEC.
DO NOT REPRODUCE OR DISCLOSE TO
OTHERS WITHOUT EXPRESS WRITTEN
CONSENT OF IN/DMATEC.

REVISIONS					
REV.	BY	DESCRIPTION	DATE	BY	APPROVED

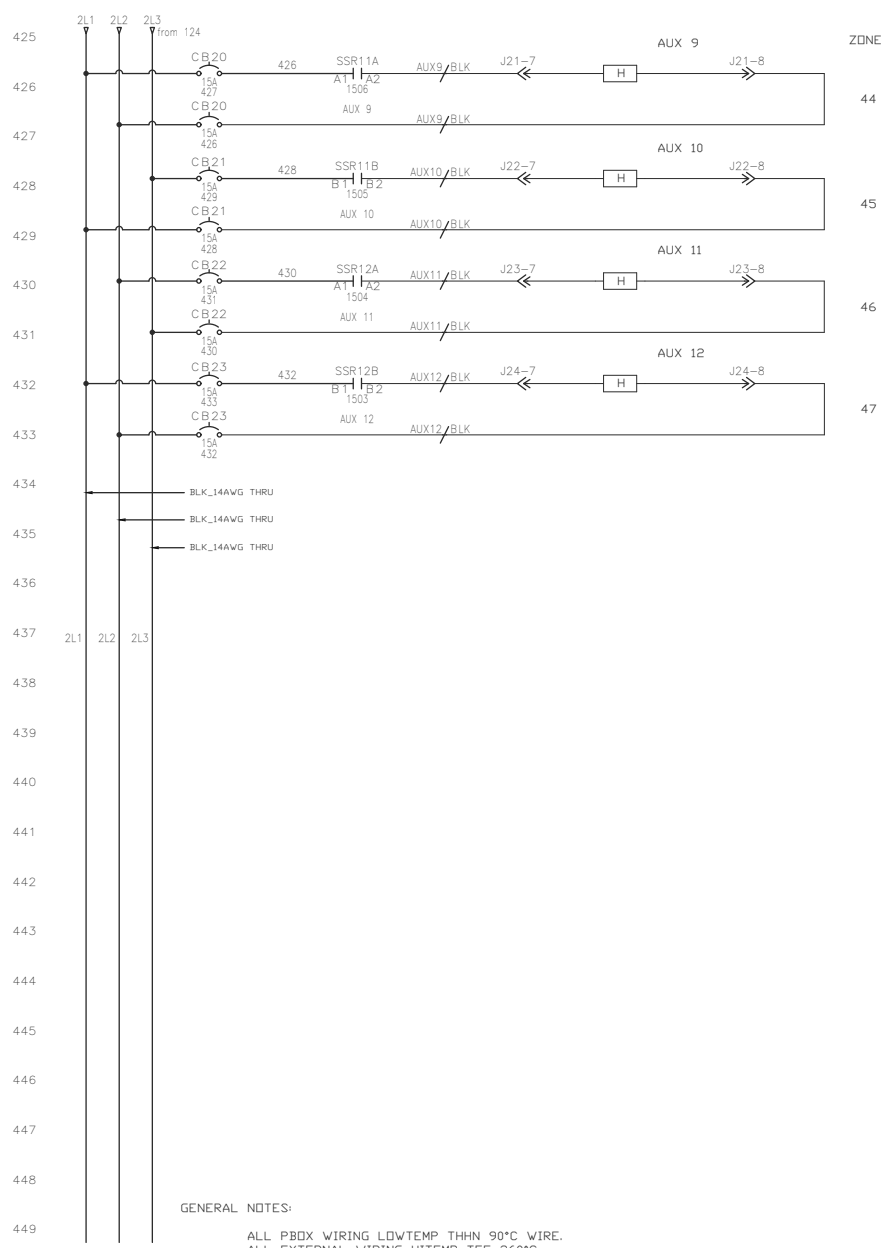
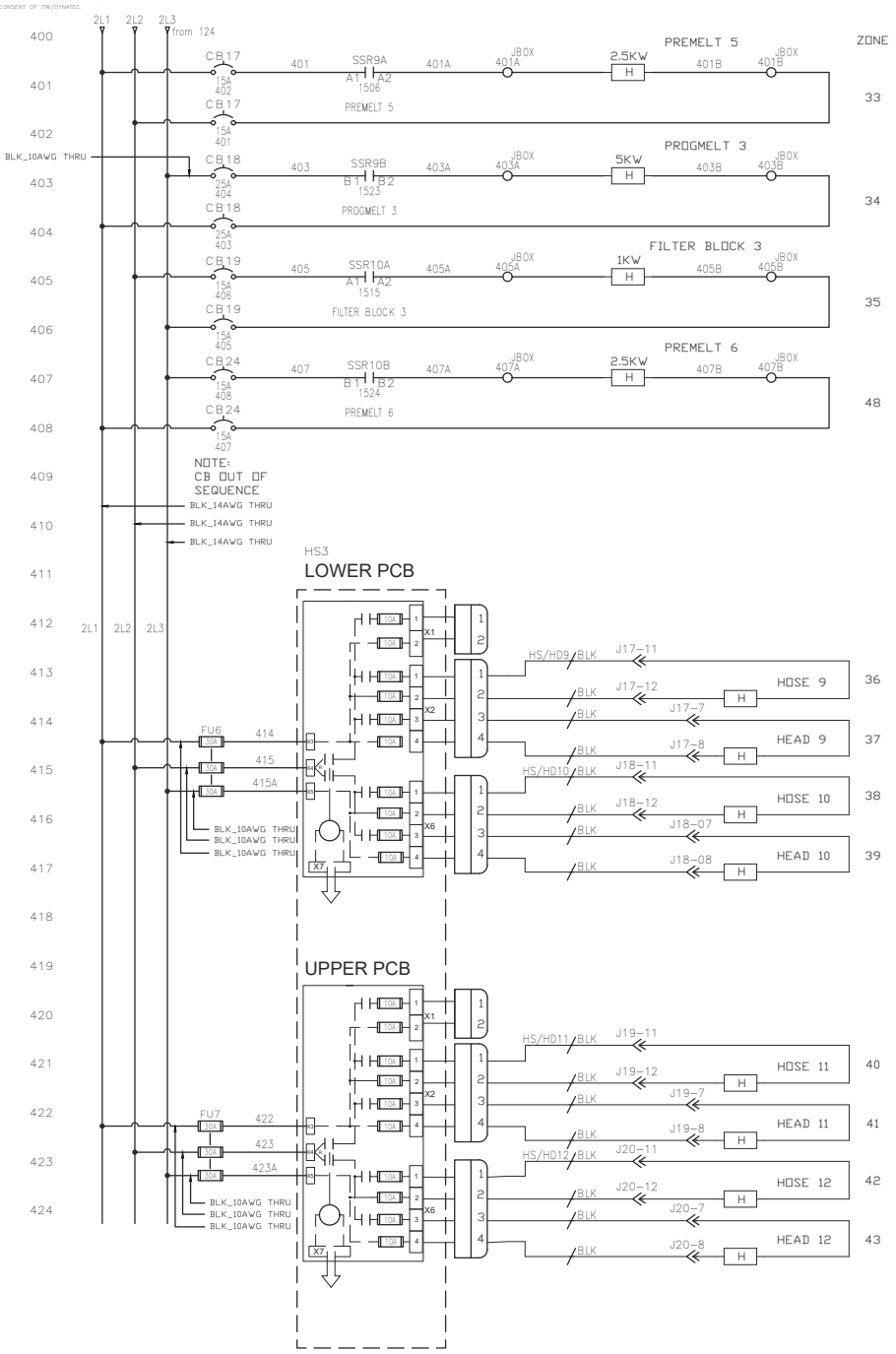

GENERAL NOTES:

- ALL PBOX WIRING LOWTEMP THHN 90°C WIRE.
- ALL EXTERNAL WIRING HITEMP TFE 260°C OR EQUIV.
- DENOTES TERMINAL IN PBOX
- DENOTES TERMINAL IN JBOX
- APPLY WIRE NUMBERS TO BOTH ENDS OF WIRE.
- DENOTES DEVICES EXTERNAL TO PBOX.
- WIRE ALL GROUND CONNECTIONS PER DRAWING 804704.
- THIS IS A GENERAL SCHEMATIC. NOT ALL DEVICES MAY BE PRESENT. SEE ORDER FOR NUMBER OF HOSES, HEADS, AUX, AND MOTORS.

ITEM	PART NUMBER	QTY	UOM	DESCRIPTION
PARTS LIST				
TOLERANCES (UNLESS OTHERWISE SPECIFIED)				
DO NOT SCALE DRAWING		STATUS		DESIGN
COMPUTER DESCRIPTIONS (CHARACTERS)		NEXT ASSY		SCALE: DRAWN BY: CHECKED BY: APP'D BY:
FOR MACHINING STANDARDS AND DIMENSIONS, SEE IN/DMATEC SPEC. AND/OR		SOURCE: REV. U		DATE: 09.30.13 SHEET 4 OF SHEETS 17 DRAWING NO. 820863



TITLE: V6, M210, 240V, SH HEATER CIRCUITS

THIS DRAWING IS THE PROPERTY OF INVA/DYNATEC.
DO NOT REPRODUCE OR DISCLOSE TO
OTHERS WITHOUT EXPRESS WRITTEN
CONSENT OF INVA/DYNATEC.

REVISIONS					
REV.	REV.	DESCRIPTION	DATE	BY	APPROVED

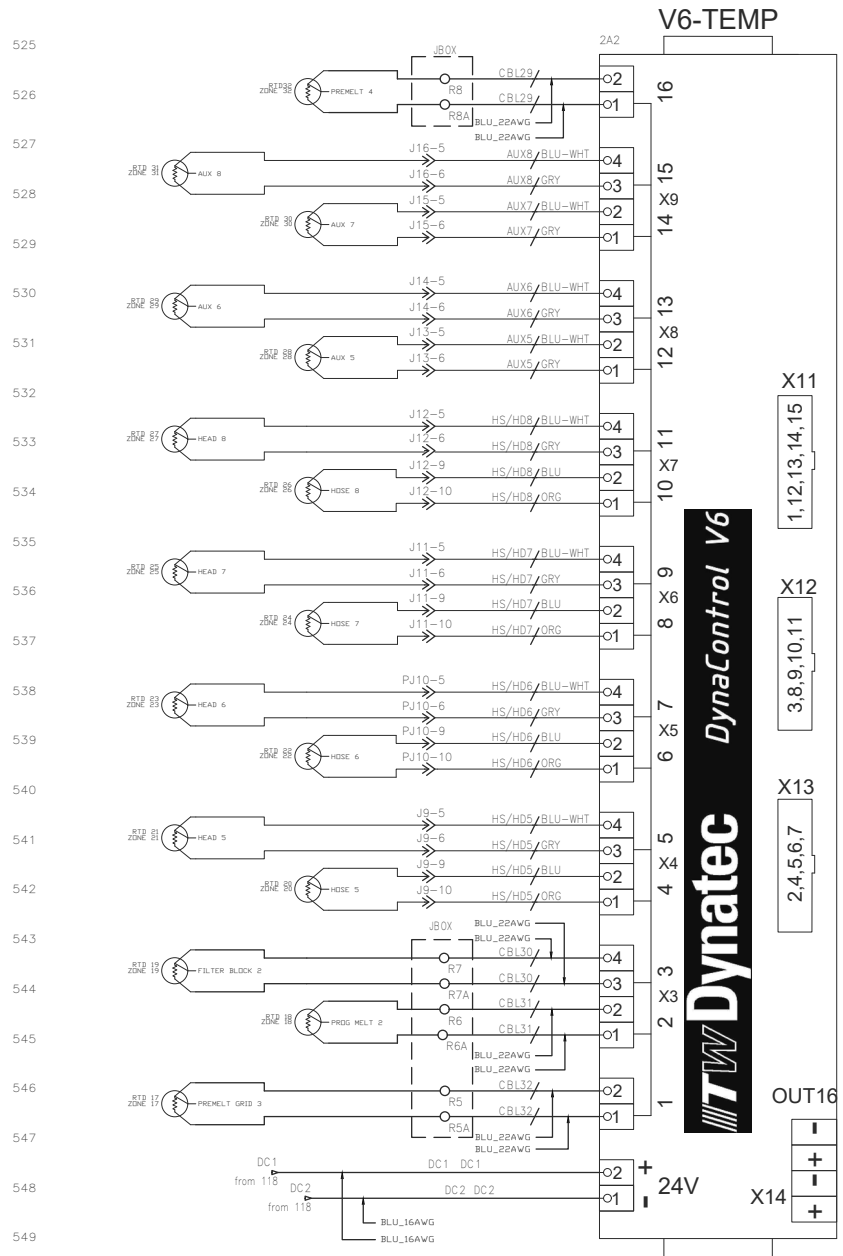
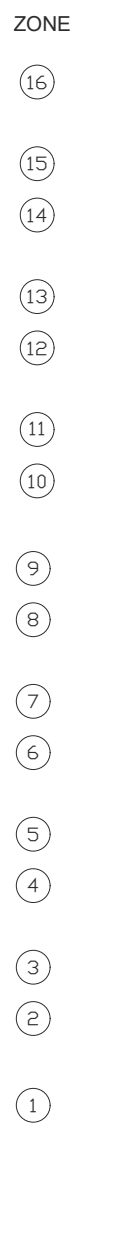
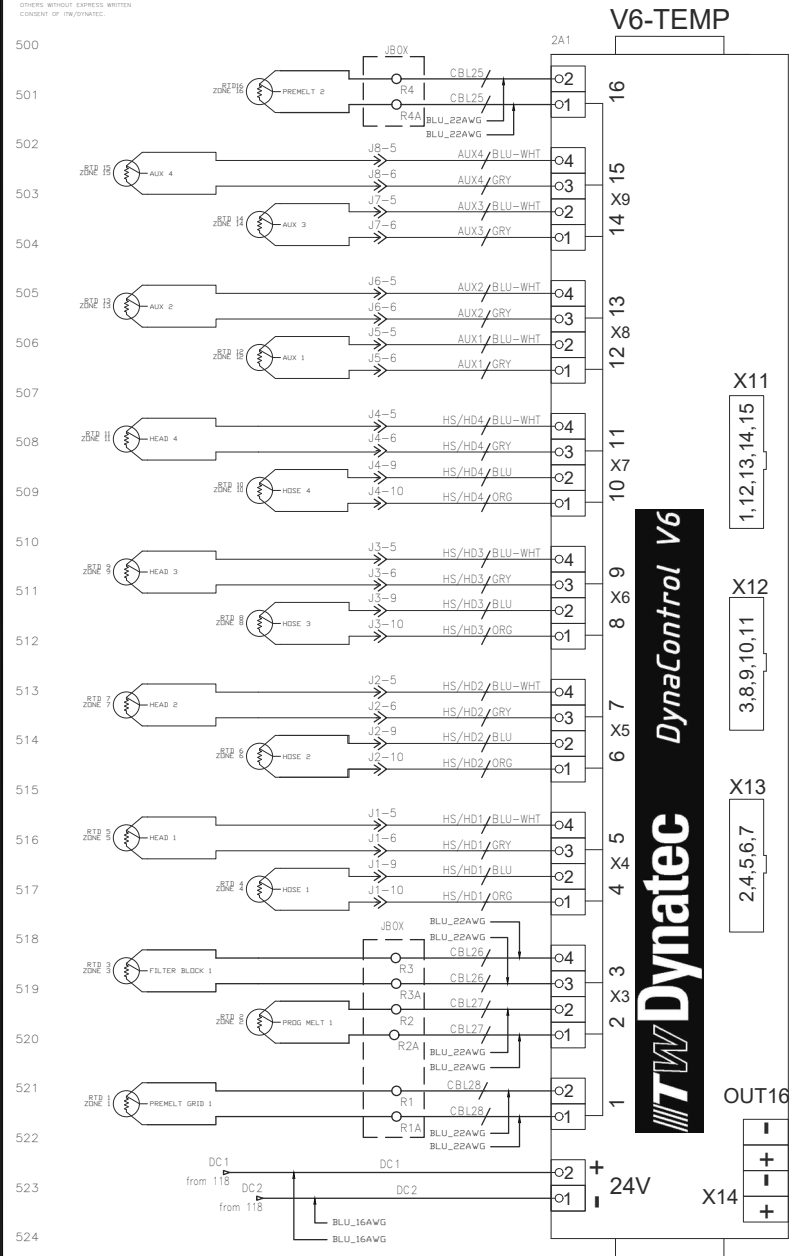

ITEM	PART NUMBER	QTY	UOM	PARTS LIST	DESCRIPTION

DO NOT SCALE DRAWING		TOLERANCES (UNLESS OTHERWISE SPECIFIED)		Dynatec	
COMPUTER DESCRIPTIONS (CHARACTERS)		NEXT ASSY		TITLE: V6, M210, 240V, SH	
FOR MACHINING STANDARDS AND DIMENSIONS, SEE INVA/DYNATEC SPEC. ADDRESS		SOURCE: U		RTD INPUTS	
DATE: 09.30.13		SHEET 5 OF SHEETS 17		DRAWN BY: BFG	
				CHECKED BY: ---	
				APPROVED BY: ---	
				DRAWING NO: 820863	

THIS DRAWING IS THE PROPERTY OF ITW/DYNATEC.
DO NOT REPRODUCE OR DISCLOSE TO
OTHERS WITHOUT EXPRESS WRITTEN
CONSENT OF ITW/DYNATEC.

REVISIONS					
REV.	REV.	DESCRIPTION	DATE	BY	APPROVED

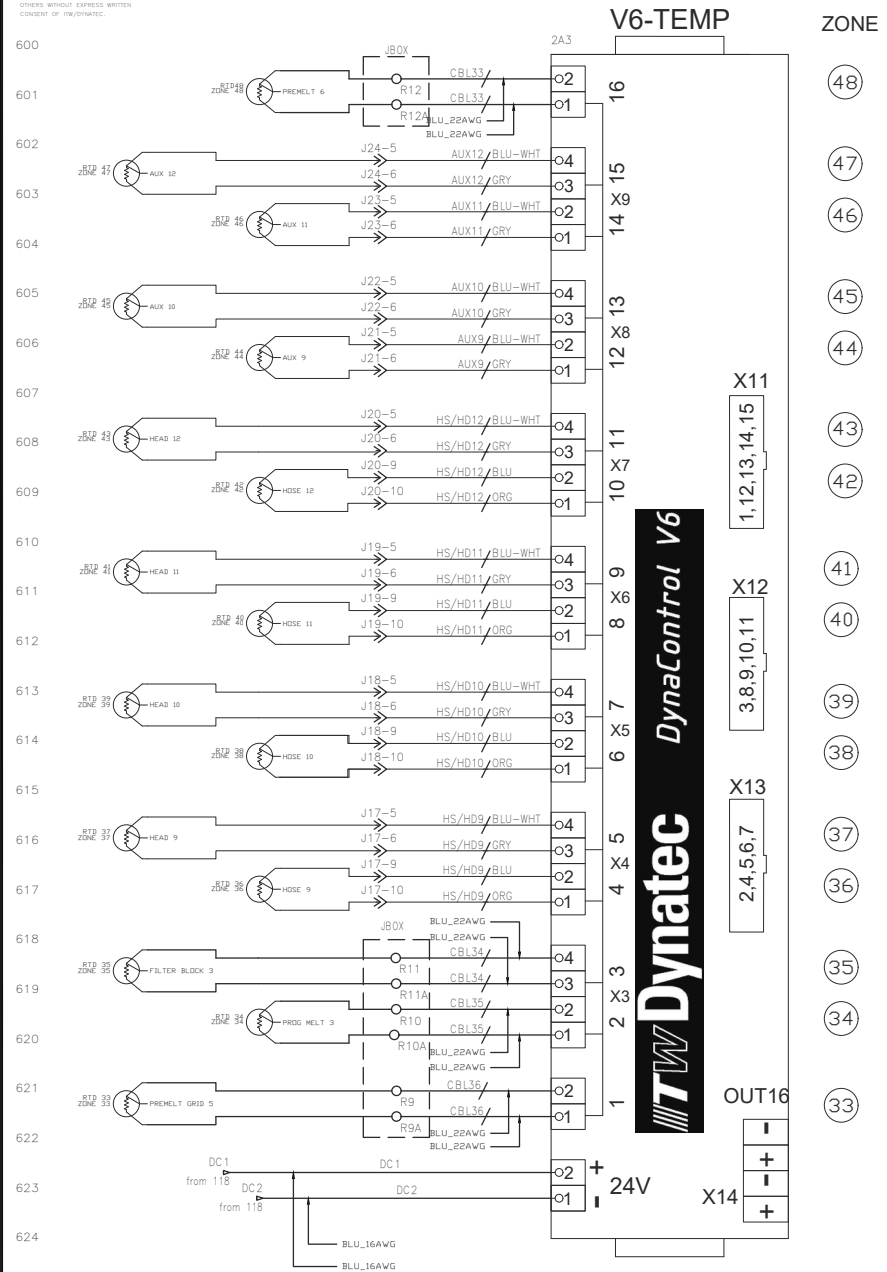

ITEM	PART NUMBER	QTY	UOM	DESCRIPTION																																				
PARTS LIST																																								
<table border="1"> <tr> <td colspan="2">DO NOT SCALE DRAWING</td> <td colspan="2">TOLERANCES (UNLESS OTHERWISE SPECIFIED)</td> <td colspan="2">ITW Dynatec</td> </tr> <tr> <td colspan="2">COMPUTER DESCRIPTIONS (CHARACTERS)</td> <td colspan="2">NEXT ASSY</td> <td colspan="2">TITLE: V6, M210, 240V, SH</td> </tr> <tr> <td colspan="2">FOR MACHINING STANDARDS AND DIMENSIONS, SEE ITW/DYNATEC SPEC. A03509</td> <td colspan="2">SOURCE: U</td> <td colspan="2">RTD INPUTS</td> </tr> <tr> <td colspan="2">DATE: 09.30.13</td> <td colspan="2">SHEET: 6</td> <td colspan="2">OF SHEETS: 17</td> </tr> <tr> <td colspan="2">DRAWN BY: BFG</td> <td colspan="2">CHECKED BY: ---</td> <td colspan="2">APPROVED BY: ---</td> </tr> <tr> <td colspan="2">DRAWING NO: 820863</td> <td colspan="2"> </td> <td colspan="2"> </td> </tr> </table>					DO NOT SCALE DRAWING		TOLERANCES (UNLESS OTHERWISE SPECIFIED)		ITW Dynatec		COMPUTER DESCRIPTIONS (CHARACTERS)		NEXT ASSY		TITLE: V6, M210, 240V, SH		FOR MACHINING STANDARDS AND DIMENSIONS, SEE ITW/DYNATEC SPEC. A03509		SOURCE: U		RTD INPUTS		DATE: 09.30.13		SHEET: 6		OF SHEETS: 17		DRAWN BY: BFG		CHECKED BY: ---		APPROVED BY: ---		DRAWING NO: 820863					
DO NOT SCALE DRAWING		TOLERANCES (UNLESS OTHERWISE SPECIFIED)		ITW Dynatec																																				
COMPUTER DESCRIPTIONS (CHARACTERS)		NEXT ASSY		TITLE: V6, M210, 240V, SH																																				
FOR MACHINING STANDARDS AND DIMENSIONS, SEE ITW/DYNATEC SPEC. A03509		SOURCE: U		RTD INPUTS																																				
DATE: 09.30.13		SHEET: 6		OF SHEETS: 17																																				
DRAWN BY: BFG		CHECKED BY: ---		APPROVED BY: ---																																				
DRAWING NO: 820863																																								

REVISIONS					
REV.	BY	DESCRIPTION	DATE	BY	APPROVED

THIS DRAWING IS THE PROPERTY OF INVA/DYNATEC.
DO NOT REPRODUCE OR DISCLOSE TO
OTHERS WITHOUT EXPRESS WRITTEN
CONSENT OF INVA/DYNATEC.

700
701
702
703
704
705
706
707
708
709
710
711
712
713
714
715
716
717
718
719
720
721
722
723
724

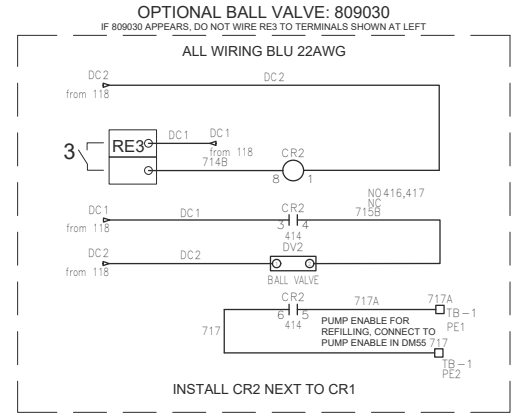
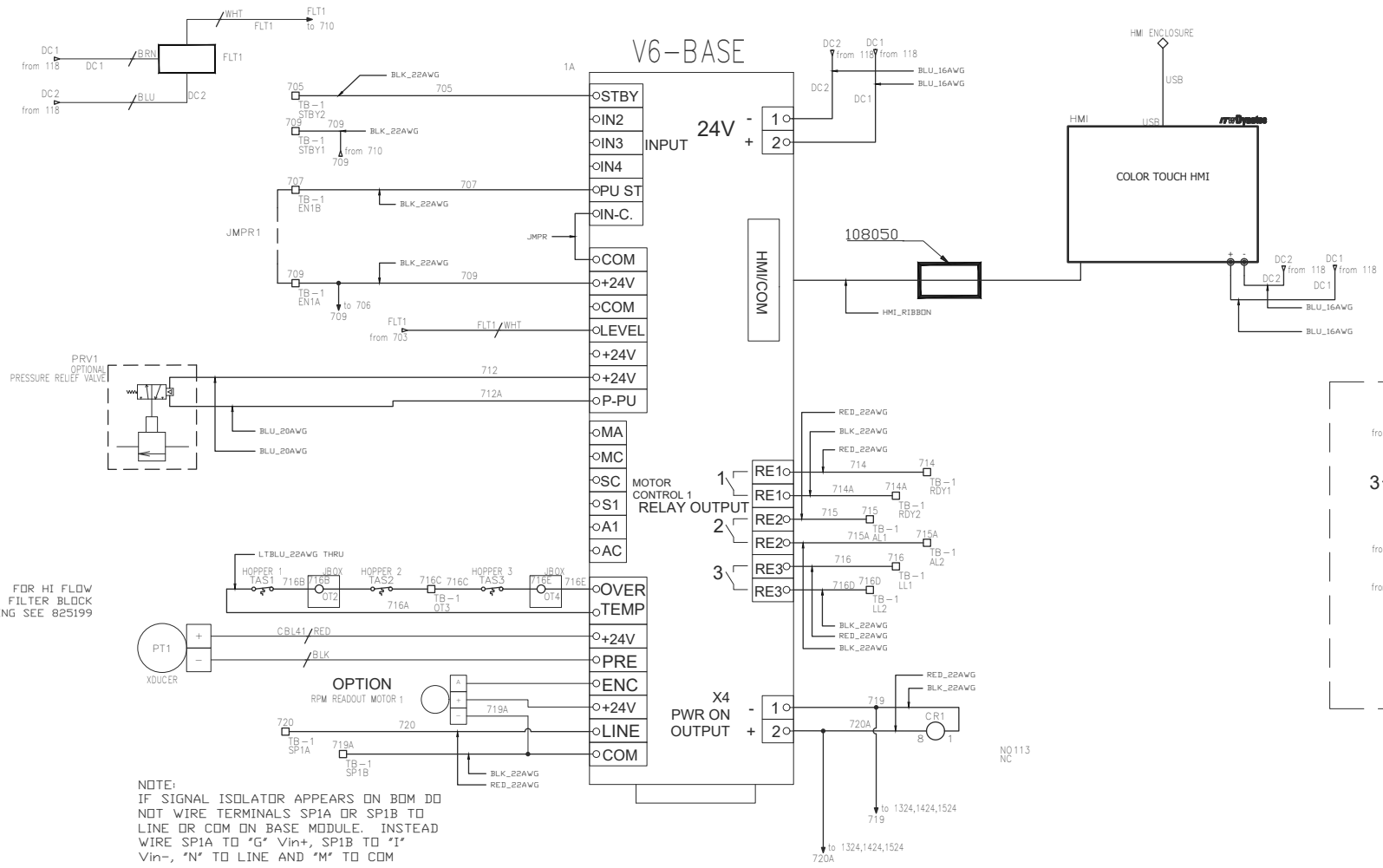

NOTE:
IF SIGNAL ISOLATOR APPEARS ON BOM DO
NOT WIRE TERMINALS SP1A OR SP1B TO
LINE OR COM ON BASE MODULE. INSTEAD
WIRE SP1A TO 'G' Vin+, SP1B TO 'I'
Vin-, 'N' TO LINE AND 'M' TO COM

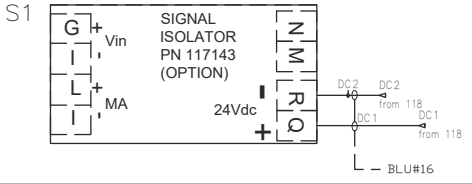

ITEM	PART NUMBER	QTY	UOM	DESCRIPTION

DO NOT SCALE DRAWING		TOLERANCES (UNLESS OTHERWISE SPECIFIED)		TITLE: V6_M210_240V_SH BASE MODULE	
COMPUTER DESCRIPTIONS (CHARACTERS)	NEXT ASSY	STATUS	REV	SCALE:	DRAWN BY: B FQ
FOR MACHINING STANDARDS AND DIMENSIONS, SEE INVA/DYNATEC SPEC. APPENDIX				DATE: 09.30.13	CHECKED BY: ---
				SOURCE: U	APPROD BY: ---
					DATE: 09.30.13
					SHEET 7 OF SHEETS 17
					DRAWING NO: 820863

THIS DRAWING IS THE PROPERTY OF ITW/DYNATEC.
DO NOT REPRODUCE OR DISCLOSE TO
OTHERS WITHOUT EXPRESS WRITTEN
CONSENT OF ITW/DYNATEC.

REVISIONS				
REV.	BY	DESCRIPTION	DATE	APP'D BY

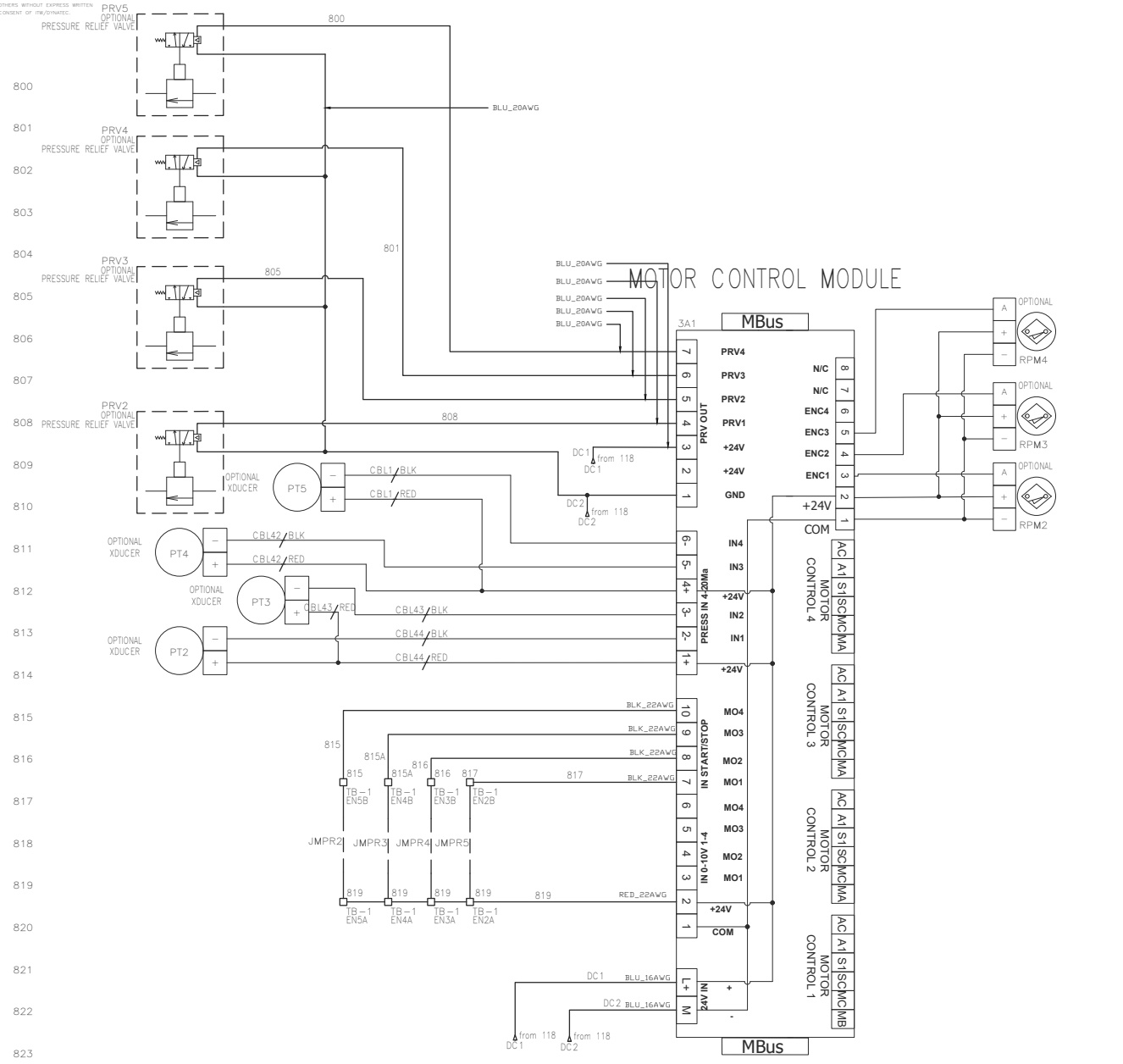

ITEM	PART NUMBER	QTY	UOM	DESCRIPTION																																												
PARTS LIST																																																
<table border="1"> <tr> <td colspan="2">TOLERANCES (UNLESS OTHERWISE SPECIFIED)</td> <td colspan="3" rowspan="2"> </td> </tr> <tr> <td>U/M</td> <td>STATUS</td> <td>DATE</td> <td>SCALE</td> </tr> <tr> <td colspan="2">DO NOT SCALE DRAWING</td> <td>DATE</td> <td>SCALE</td> <td>TITLE: V6, M210, 240V, SH PRESSURE INPUTS</td> </tr> <tr> <td colspan="2">COMPUTER DESCRIPTIONS (CHARACTERS)</td> <td>DATE</td> <td>SCALE</td> <td>CHECKED BY: ---</td> </tr> <tr> <td colspan="2">FOR MACHINING STANDARDS AND DIMENSIONS, SEE ITW/DYNATEC SPEC. A05030</td> <td>DATE</td> <td>SCALE</td> <td>APPROVED BY: ---</td> </tr> <tr> <td colspan="2">NEXT ASSY</td> <td>DATE</td> <td>SCALE</td> <td>DRAWN BY: BFC</td> </tr> <tr> <td colspan="2">SOURCE</td> <td>DATE</td> <td>SCALE</td> <td>CHECKED BY: ---</td> </tr> <tr> <td colspan="2">U</td> <td>DATE</td> <td>SCALE</td> <td>APPROVED BY: ---</td> </tr> <tr> <td colspan="2">U</td> <td>DATE</td> <td>SCALE</td> <td>APPROVED BY: ---</td> </tr> </table>					TOLERANCES (UNLESS OTHERWISE SPECIFIED)					U/M	STATUS	DATE	SCALE	DO NOT SCALE DRAWING		DATE	SCALE	TITLE: V6, M210, 240V, SH PRESSURE INPUTS	COMPUTER DESCRIPTIONS (CHARACTERS)		DATE	SCALE	CHECKED BY: ---	FOR MACHINING STANDARDS AND DIMENSIONS, SEE ITW/DYNATEC SPEC. A05030		DATE	SCALE	APPROVED BY: ---	NEXT ASSY		DATE	SCALE	DRAWN BY: BFC	SOURCE		DATE	SCALE	CHECKED BY: ---	U		DATE	SCALE	APPROVED BY: ---	U		DATE	SCALE	APPROVED BY: ---
TOLERANCES (UNLESS OTHERWISE SPECIFIED)																																																
U/M	STATUS				DATE	SCALE																																										
DO NOT SCALE DRAWING		DATE	SCALE	TITLE: V6, M210, 240V, SH PRESSURE INPUTS																																												
COMPUTER DESCRIPTIONS (CHARACTERS)		DATE	SCALE	CHECKED BY: ---																																												
FOR MACHINING STANDARDS AND DIMENSIONS, SEE ITW/DYNATEC SPEC. A05030		DATE	SCALE	APPROVED BY: ---																																												
NEXT ASSY		DATE	SCALE	DRAWN BY: BFC																																												
SOURCE		DATE	SCALE	CHECKED BY: ---																																												
U		DATE	SCALE	APPROVED BY: ---																																												
U		DATE	SCALE	APPROVED BY: ---																																												
FOR MACHINING STANDARDS AND DIMENSIONS, SEE ITW/DYNATEC SPEC. A05030		DATE	SCALE	APPROVED BY: ---																																												
NEXT ASSY		DATE	SCALE	DRAWN BY: BFC																																												
SOURCE		DATE	SCALE	CHECKED BY: ---																																												
U		DATE	SCALE	APPROVED BY: ---																																												
U		DATE	SCALE	APPROVED BY: ---																																												

800

801

802

803

804

805

806

807

808

809

810

811

812

813

814

815

816

817

818

819

820

821

822

823

824

REVISIONS					
REV.	BY	DESCRIPTION	DATE	BY	APPROVED

THIS DRAWING IS THE PROPERTY OF DYWIDAG-IDA. IT IS TO BE KEPT IN CONFIDENCE AND NOT REPRODUCED OR DISCLOSED TO OTHERS WITHOUT EXPRESS WRITTEN CONSENT OF DYWIDAG-IDA.

IF THE LINE SIZE OF CIRCUIT BREAKER TO BE INSTALLED IS NOT INDICATED, IT IS TO BE 15A. IF AN OPTIONAL DISCONNECT KIT IS PRESENT, IT IS TO BE 15A.

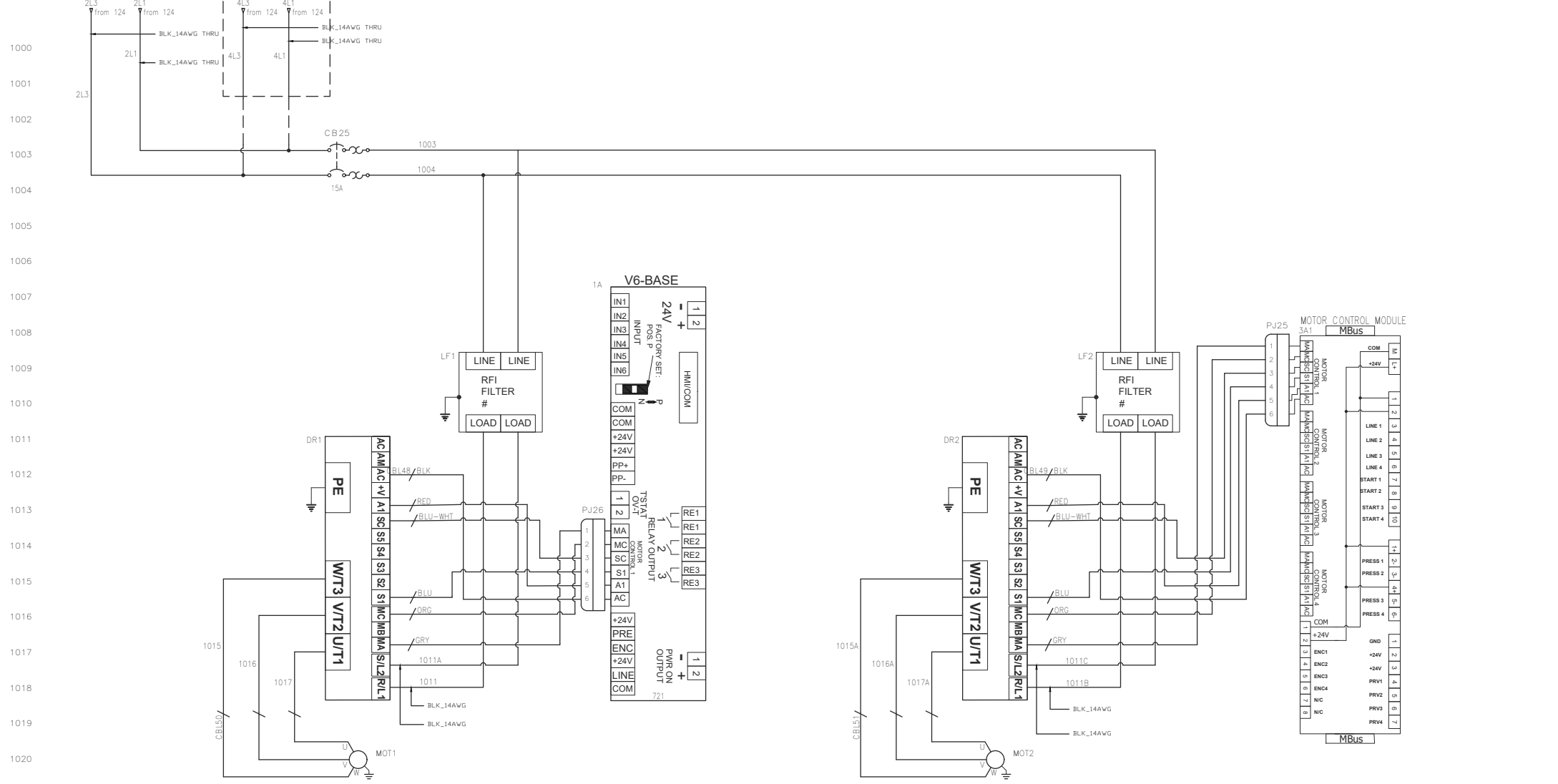

1000
1001
1002
1003
1004
1005
1006
1007
1008
1009
1010
1011
1012
1013
1014
1015
1016
1017
1018
1019
1020
1021
1022
1023
1024

ITEM	PART NUMBER	QTY	U/M	DESCRIPTION

DO NOT SCALE DRAWING		REFERENCES (UNLESS OTHERWISE SPECIFIED)		 TITLE: V6, M210, 240V, SH DRIVE INPUT	
COMPUTER DESCRIPTIONS (CHARACTERS)	NEXT ASSY	STATUS	REV		
				SCALE:	DRAWN BY: BFO
				DATE: 09.30.13	CHECKED BY: ---
				SHEET 10	OF SHEETS 17
					DRAWING NO: 820863

THIS DRAWING IS THE PROPERTY OF INVA/DYNATEC.
DO NOT REPRODUCE OR DISCLOSE TO
OTHERS WITHOUT EXPRESS WRITTEN
CONSENT OF INVA/DYNATEC.

REVISIONS					
REV.	BY	DESCRIPTION	DATE	BY	APPROVED

1200
1201
1202
1203
1204
1205
1206
1207
1208
1209
1210
1211
1212
1213
1214
1215
1216
1217
1218
1219
1220
1221
1222
1223
1224

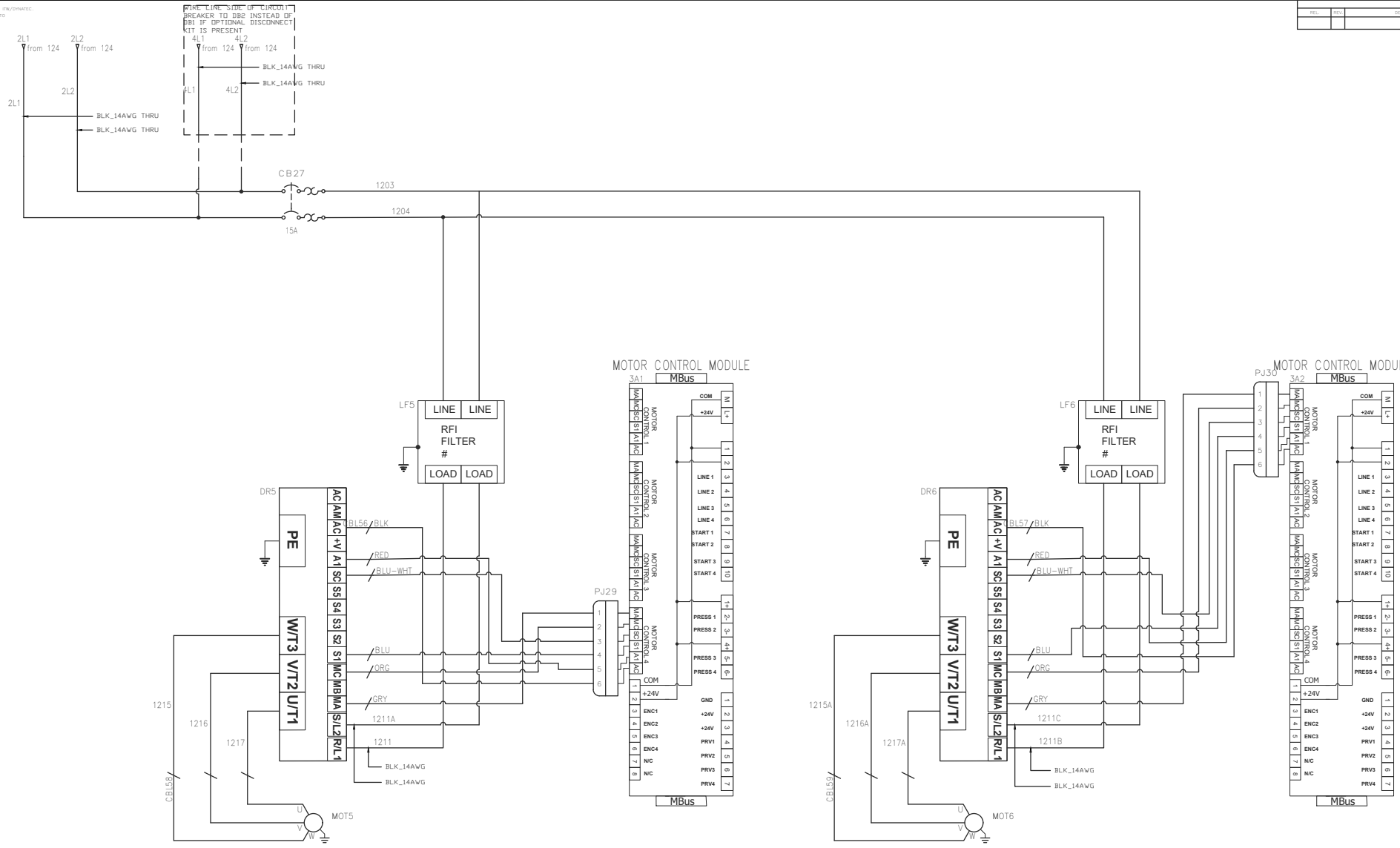

ITEM	PART NUMBER	QTY	U/M	PARTS LIST	DESCRIPTION

DO NOT SCALE DRAWING		TOLERANCES (UNLESS OTHERWISE SPECIFIED)			
COMPUTER DESCRIPTIONS (CHARACTERS)	NEXT ASSY	STATUS	REV		
FOR MACHINING STANDARDS AND DIMENSIONS, SEE INVA/DYNATEC SPEC. APPROX		SCALE:	DRAWN BY:	CHECKED BY:	APP'D BY:
DATE:	SHEET	OF SHEETS	DRAWING NO.		
09.30.13	12	17	820863		

THIS DRAWING IS THE PROPERTY OF ITW/DYNATEC.
DO NOT REPRODUCE OR DISCLOSE TO
OTHERS WITHOUT EXPRESS WRITTEN
CONSENT OF ITW/DYNATEC.

REVISIONS					
REV.	BY	DESCRIPTION	DATE	BY	APPROVED

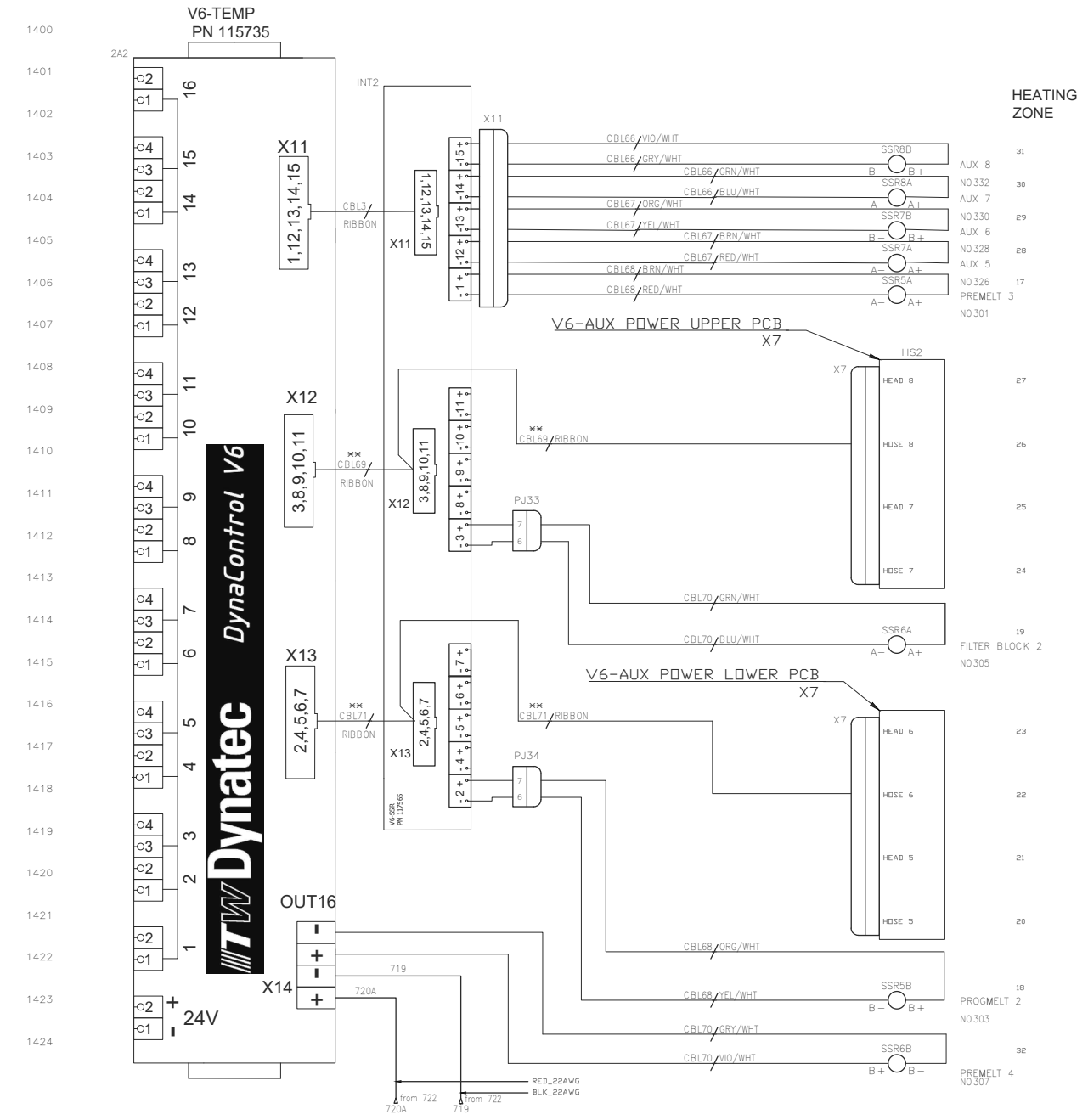

****NOTE**

CONFIGURATION SHOWN IS FOR IS FOR A SYSTEM WITH EIGHT OR MORE HOSE/HEAD CONNECTIONS REQUIRED WHERE CBL69 AND CBL71 ARE DUAL CABLES (P/N 823321). FOR A SYSTEM WITH LESS THAN EIGHT HOSE/HEAD CONNECTIONS, A SINGLE CABLE (P/N 823319) IS CONNECTED BETWEEN CONNECTOR X12/X13 ON V6-TEMP AND X12/X13 ON INT2 WHERE A PCB HOSE/HEAD CONNECTION IS NOT REQUIRED.

ITEM	PART NUMBER	QTY	UOM	DESCRIPTION

DO NOT SCALE DRAWING		TOLERANCES (UNLESS OTHERWISE SPECIFIED)			
COMPUTER DESCRIPTIONS (CHARACTERS)	NEXT ASSY	STATUS	REV	TITLE: V6,M210,240V,SH	PROPORTIONVILLE, TN
FOR MACHINING STANDARDS AND DIMENSIONS, SEE ITW/DYNATEC SPEC. APPROB.	SCALE: BFO	CHECKED BY: ---	APPROV BY: ---	DATE: 09.30.13	SHEET 14 OF SHEETS 17

THIS DRAWING IS THE PROPERTY OF INVA/DYNATEC.
DO NOT REPRODUCE OR DISCLOSE TO
OTHERS WITHOUT EXPRESS WRITTEN
CONSENT OF INVA/DYNATEC.

REVISIONS				
REV.	BY	DESCRIPTION	DATE	APPROVED

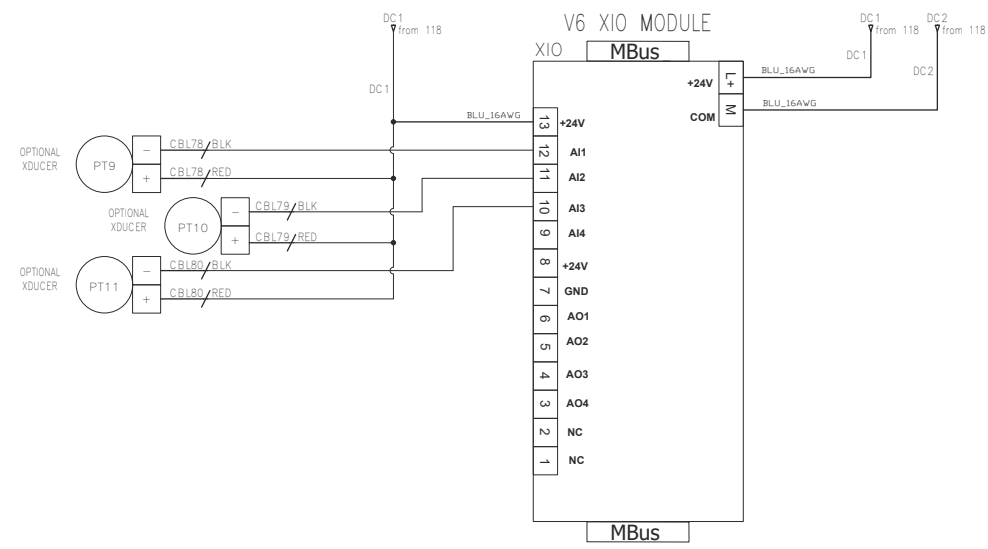
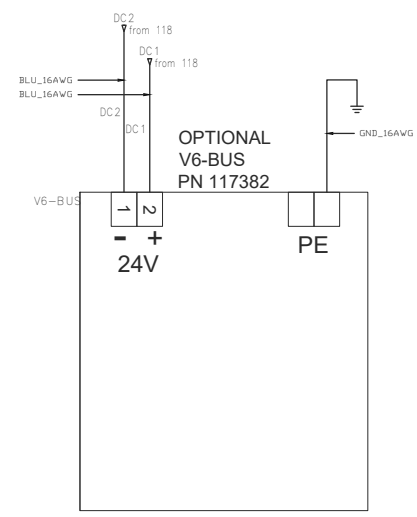

1600
1601
1602
1603
1604
1605
1606
1607
1608
1609
1610
1611
1612
1613
1614
1615
1616
1617
1618
1619
1620
1621
1622
1623
1624

ITEM	PART NUMBER	QTY	U/M	DESCRIPTION
PARTS LIST				
DO NOT SCALE DRAWING NEXT ASSY				TOLERANCES (UNLESS OTHERWISE SPECIFIED)
COMPUTER DESCRIPTIONS (CHARACTERS)				Dynatec <small>MEMPHIS, TENNESSEE, TN</small>
TITLE: V6, M210, 240V, SH OPTIONS				U/M: SEE:
FOR MACHINING STANDARDS AND DIMENSIONS, SEE INV/CHARACTER SPEC. ADDRESS		SOURCE: REV:	SCALE: DRAWN BY: CHECKED BY: APP'D BY:	DATE: 09.30.13 SHEET 16 OF SHEETS 17 DRAWING NO. 820863

THIS DRAWING IS THE PROPERTY OF RW/DYNATEC.
DO NOT REPRODUCE OR DISCLOSE TO
OTHERS WITHOUT EXPRESS WRITTEN
CONSENT OF RW/DYNATEC.

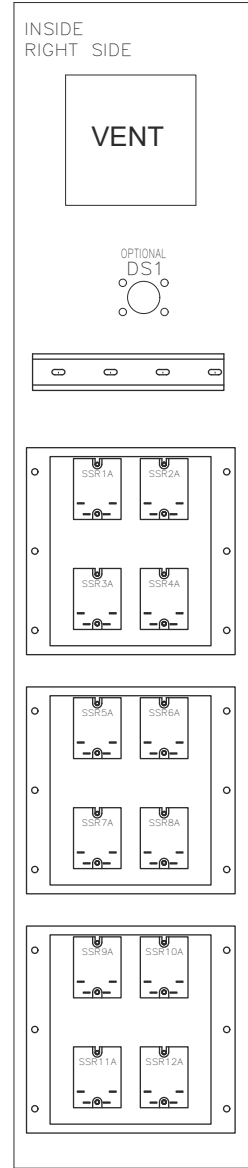
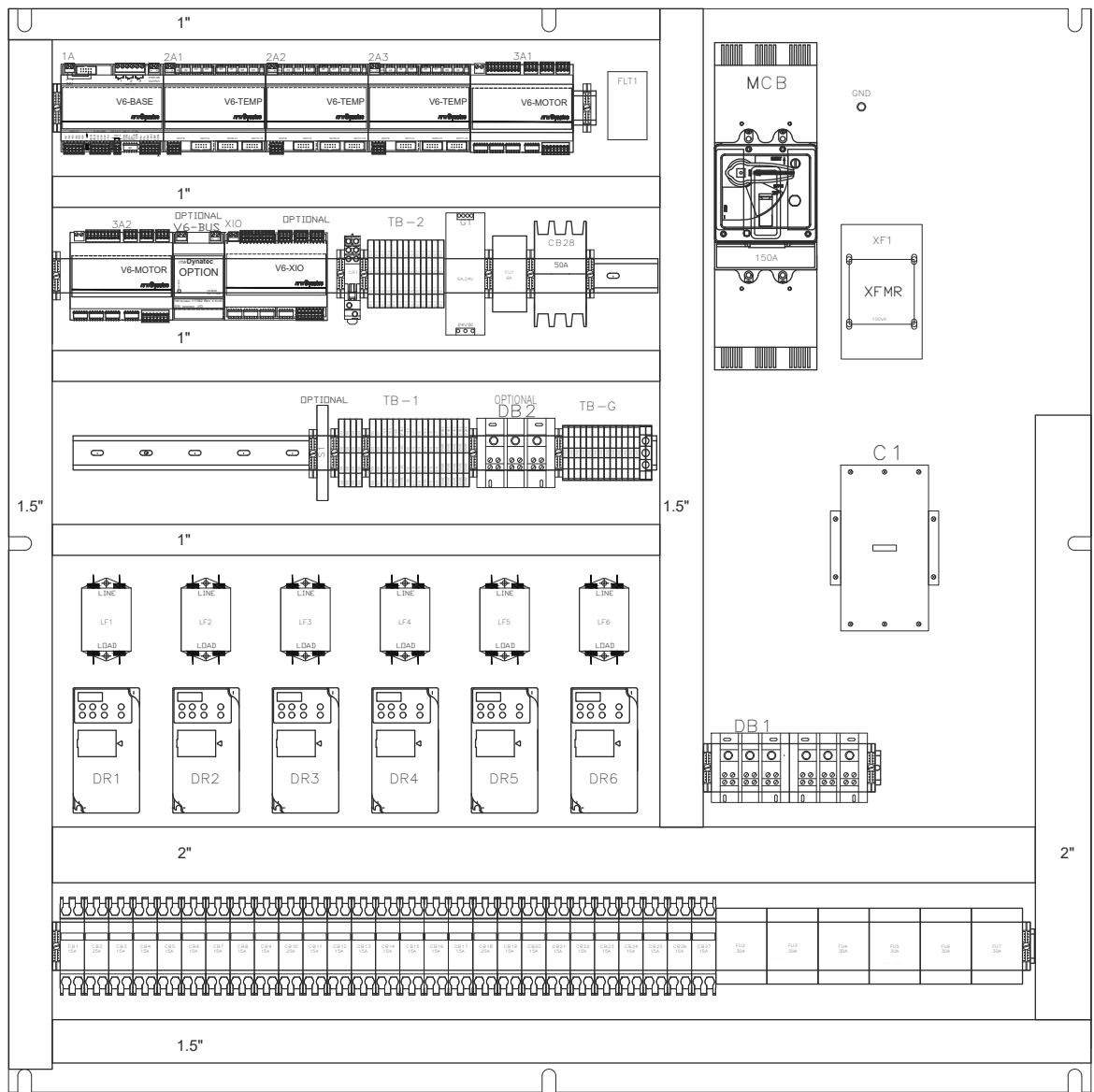
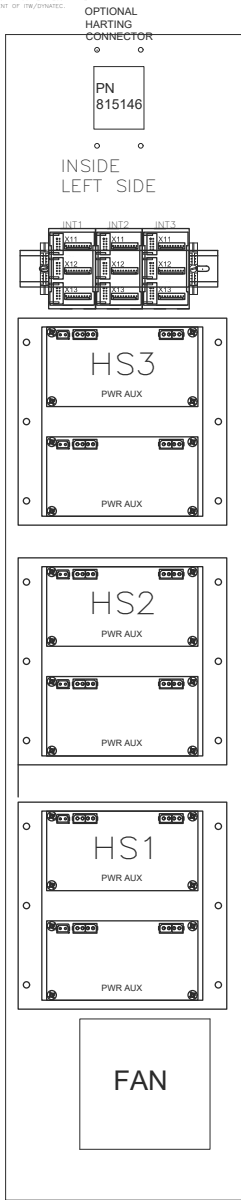

REVISIONS					
REV.	BY	DESCRIPTION	DATE	BY / APPROVED	
TB-1					
LOWER TERMINAL	WIRE NO	DESC (REF)	UPPER TERMINAL	WIRE NO	DESC (REF)
109	240VAC		108	240VAC	
109	240VAC		108	240VAC	
109	240VAC		108	240VAC	
109	240VAC		108	240VAC	
705	STBY		705	STBY	
707	ENB		709	ENB	
714A	RTB		714	RTB	
717	ALP		715	ALL	
716B	LLP		716	LLI	
SPARE	SPARE		716R	RTF	
719A	SP1B		720	SP1A	
817	ENB		819	ENB	
818	ENB		819	ENB	
815A	EN4B		819	EN4A	
815	ENB		819	ENB	
817	ENB		819	ENB	
SPARE	SPARE		SPARE	SPARE	
SPARE	SPARE		SPARE	SPARE	
SPARE	SPARE		SPARE	SPARE	
SPARE	SPARE		SPARE	SPARE	
TB-2					
LOWER TERMINAL	WIRE NO	DESC (REF)	UPPER TERMINAL	WIRE NO	DESC (REF)
DC2	0VDC		DC1	+24VDC	

TAGS	PART NUMBER	DESCRIPTION
1A	115734	V6 BASE MODULE
2A1-2A3	115735	V6 BUS EXPANSION
2A1-2A3	115735	V6 TEMPERATURE MODULE
3A1	108623	V6 MOTOR MODULE
3A2	821748	MAIN CONTACTOR
	822087	IP20 FUR CONTACTOR
	822087	CONTACTOR FOR CURV
CB1,3-9,11-17,19-27	04207	CB,15A,2P PILE
CB2,10,18	825249	CB,25A,2P PILE
CR2	825249	CONTROL RELAY
DR1	821749	DISTRIBUTION BLOCK
DR1-6	815222	VFD,HP
F1E	812596	2 POLE FUSE BLOCK,PCB
	820959	FUSE,AMPS,1,PCB
FUSE-7	812413	J POLE FUSE BLOCK,PCB
	812413	FUSE,AMP,1,PCB
G1	119186	POWER SUPPLY,6AMP,24V
GND	825990	GROUND LUG
IM1	119125	V6 IM1
IM1-3	823306	V6 POWER BOARD
LT1-6	117856	LINE FILTER
MCB	821938	CB,150A,3 PILE MAIN CIRCUIT BREAKER
	821940	MCB OPERATOR
	821942	MCB IP20 SHELL
SSR1-12	114222	DUAL CHANNEL SSR
VB-1,2	105251	DUAL TERMINAL
V6-BUS	117282	V6 COMMUNICATION MODULE
WT	102300	WT 100 TRANSFORMER
	823403	IP20 SHELL FOR TRANSFORMER
X1D	117648	V6 X1D MIDDLE

NOTE:
IF DRIVE DISCONNECT IS INCLUDED MOUNT ON
RIGHT WALL BELOW EXHAUST VENT

ITEM	PART NUMBER	QTY	UOM	DESCRIPTION																								
PARTS LIST																												
<table border="1" style="width: 100%;"> <tr> <td colspan="2">DO NOT SCALE DRAWING</td> <td colspan="2">STATUS: DES</td> <td colspan="2">SCALE: B FQ</td> <td colspan="2">DRAWN BY: B FQ</td> <td colspan="2">CHECKED BY:</td> <td colspan="2">APPD BY:</td> </tr> <tr> <td colspan="2">FOR MACHINING STANDARDS AND DIMENSIONS SEE RW/DYNATEC SPEC. APPROB</td> <td colspan="2">SOURCE: U</td> <td colspan="2">DATE: 09.30.13</td> <td colspan="2">SHEET: 17</td> <td colspan="2">OF SHEETS: 17</td> <td colspan="2">DRAWING NO: 820863</td> </tr> </table>					DO NOT SCALE DRAWING		STATUS: DES		SCALE: B FQ		DRAWN BY: B FQ		CHECKED BY:		APPD BY:		FOR MACHINING STANDARDS AND DIMENSIONS SEE RW/DYNATEC SPEC. APPROB		SOURCE: U		DATE: 09.30.13		SHEET: 17		OF SHEETS: 17		DRAWING NO: 820863	
DO NOT SCALE DRAWING		STATUS: DES		SCALE: B FQ		DRAWN BY: B FQ		CHECKED BY:		APPD BY:																		
FOR MACHINING STANDARDS AND DIMENSIONS SEE RW/DYNATEC SPEC. APPROB		SOURCE: U		DATE: 09.30.13		SHEET: 17		OF SHEETS: 17		DRAWING NO: 820863																		



TITLE: V6_M210,240V,SH LAYOUT

11.7 Schematics M210 V6 240V Dual Hopper, PN 821067T

THIS DRAWING IS THE PROPERTY OF IAW/DYNATEC.
DO NOT REPRODUCE OR DISCLOSE TO
OTHERS WITHOUT EXPRESS WRITTEN
CONSENT OF IAW/DYNATEC.

REVISIONS					
REV.	BY	DESCRIPTION	DATE	BY	APPROVED
17050	L	CONVERTED TO ACADE	07.31.17	BFG	
ECN702	M	CORRECTIONS PER ASSEMBLY	09.22.17	BFG	
8146	N	ADDED DRIVE DISCONNECT	11.26.18	BFG	
ECN576	P	ADD GND WIRE TO XF1 SECONDARY	09.27.19	DJT	
ECN82	Q	REVISE SSR CABLE DETAIL (SHT 13/14/15)	02.24.20	DJT	
ECN849	R	CORRECT DV4/5 WIRING (SHT 9/10)	03.11.20	DJT	
ECN1239	S	ADD VOLTAGE TO XF1	03.11.21	JJB	
ECN1309	T	REVISE FLT1 AND FLT2	05.17.21	JJB	

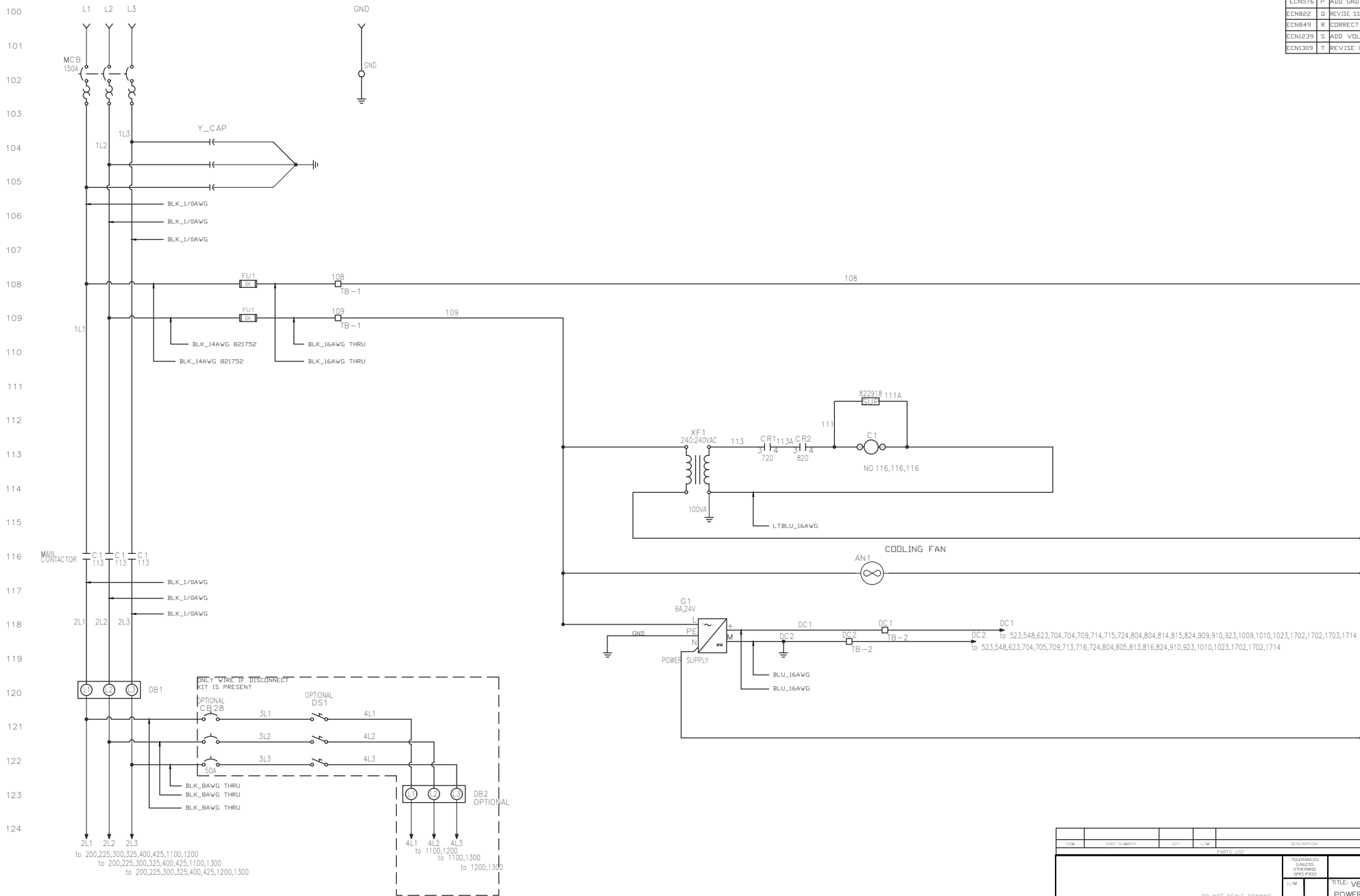

ITEM	PART NUMBER	QTY	UOM	DESCRIPTION
PARTS LIST				
TOLERANCES (UNLESS OTHERWISE SPECIFIED)				
TITLE: V6, M210, 240V, DH				
POWER DISTRIBUTION				
DO NOT SCALE DRAWING				
COMPUTER DESCRIPTIONS (CHARACTERS)		STATUS	DES	SCALE:
NEXT ASSY				BY: BFG
FOR MACHINING STANDARDS AND DIMENSIONS, SEE IAW/DYNATEC SPEC. ADDRESS		SOURCE	REV.	CHECKED BY:
		T		APP'D BY:
				DATE: 10.07.13
				SHEET 1 OF SHEETS 18
				DRAWING NO. 821067

THIS DRAWING IS THE PROPERTY OF INV/DYNATEC.
DO NOT REPRODUCE OR DISCLOSE TO
OTHERS WITHOUT EXPRESS WRITTEN
CONSENT OF INV/DYNATEC.

REV.	EN.	DESCRIPTION	DATE	BY	APPROVED
		SEE PAGE 1			

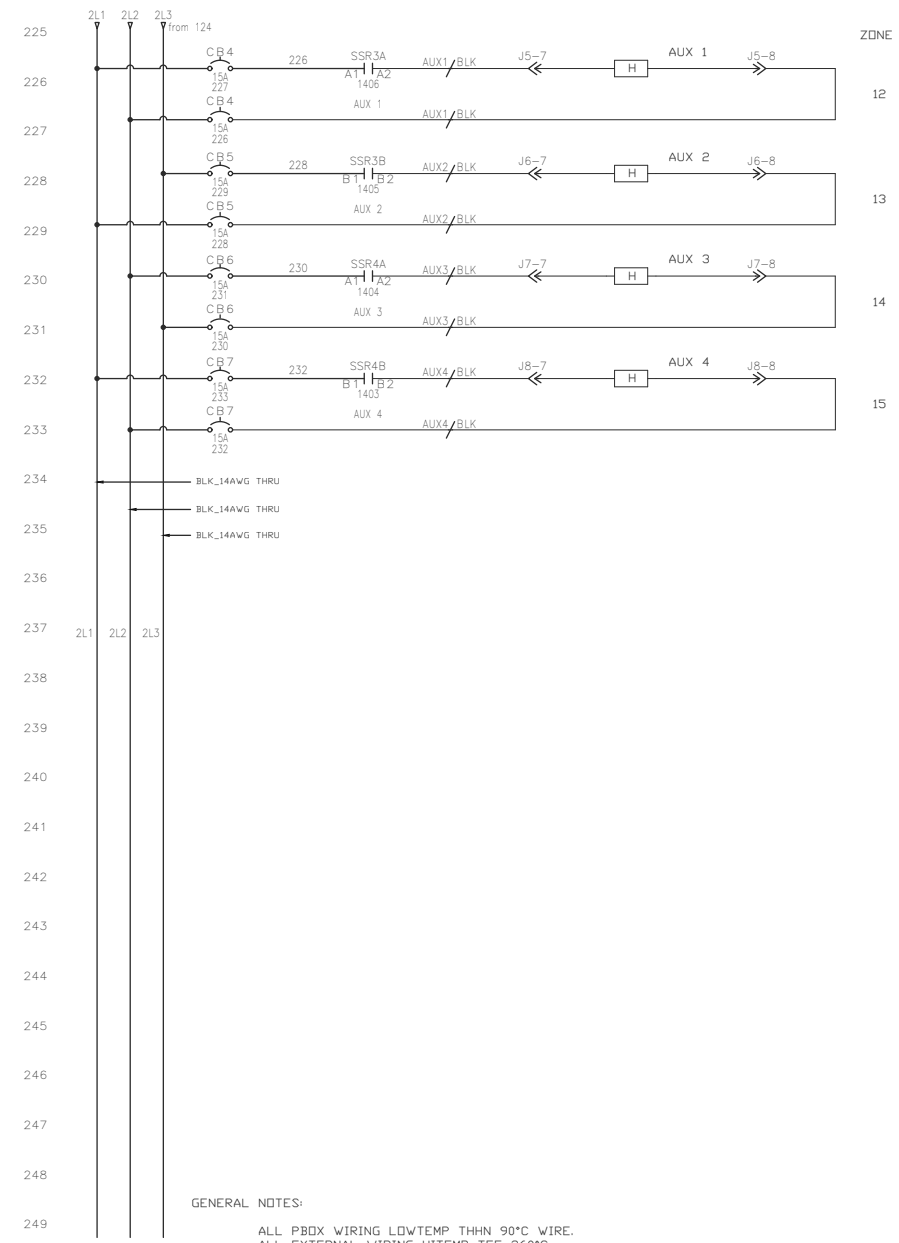
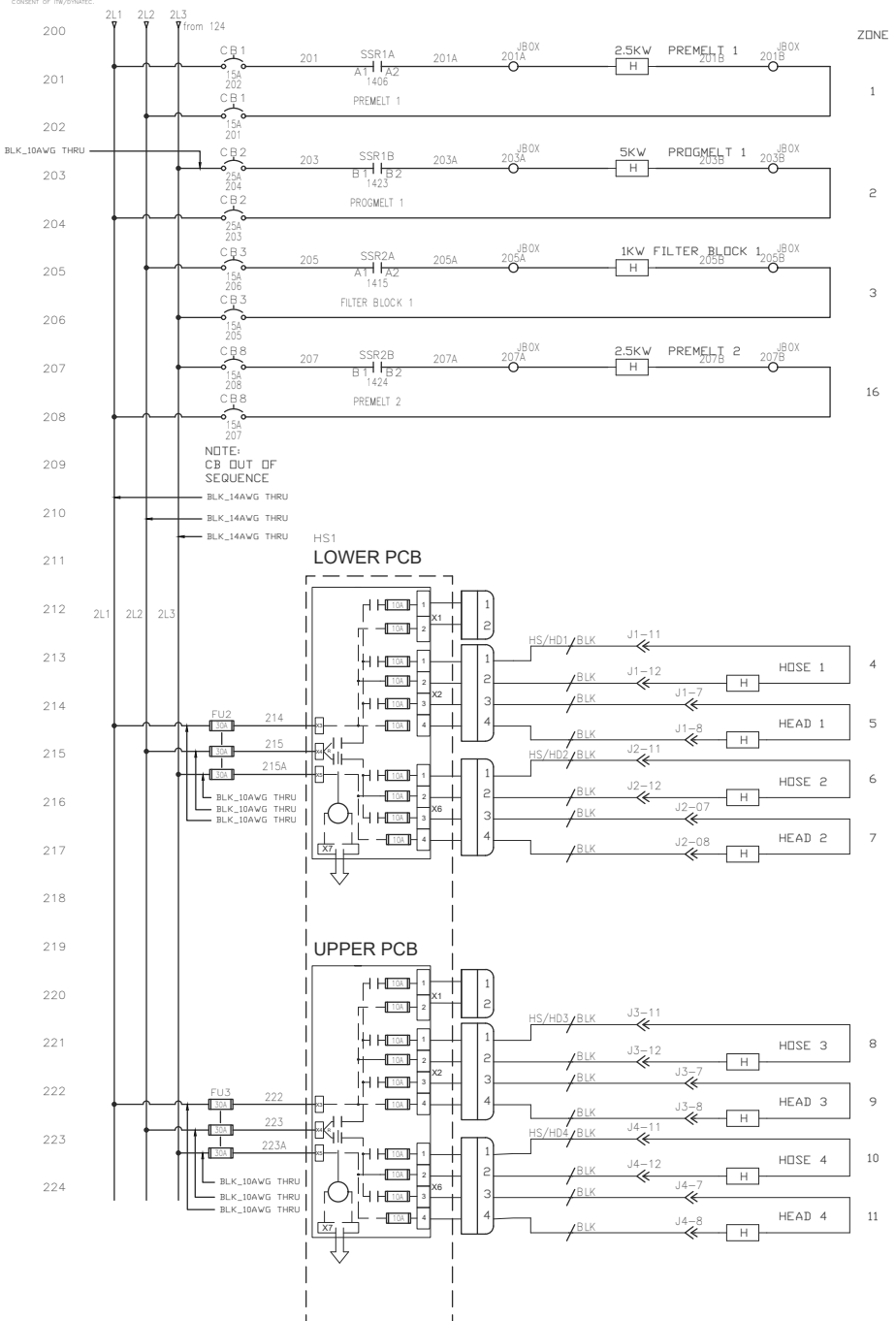

GENERAL NOTES:
 ALL PBOX WIRING LOWTEMP THHN 90°C WIRE.
 ALL EXTERNAL WIRING HITEMP TFE 260°C
 OR EQUIV.
 □ DENOTES TERMINAL IN PBOX
 ○ DENOTES TERMINAL IN JBOX
 — APPLY WIRE NUMBERS TO BOTH ENDS OF WIRE.
 — DENOTES DEVICES EXTERNAL TO PBOX.
 — WIRE ALL GROUND CONNECTIONS PER DRAWING
 804704.
 THIS IS A GENERAL SCHEMATIC. NOT ALL DEVICES
 MAY BE PRESENT. SEE ORDER FOR NUMBER
 OF HOSES, HEADS, AUX, AND MOTORS.

ITEM	PART NUMBER	QTY	UOM	DESCRIPTION
PARTS LIST				
TOLERANCES (UNLESS OTHERWISE SPECIFIED)				
DO NOT SCALE DRAWING		STATUS		DESIGN
COMPUTER DESCRIPTIONS (CHARACTERS)		NEXT ASSY		SCALE: DRAWN BY: BFO
FOR MACHINING STANDARDS AND DIMENSIONS, SEE INV/DYNATEC SPEC. A05030		DATE: 10.07.13		CHECKED BY: APP'D BY:
		SHEET 2		OF SHEETS 18
		DRAWING NO. 821067		



TITLE: V6, M210, 240V, DH
HEATER CIRCUITS

THIS DRAWING IS THE PROPERTY OF INV/DYNATEC.
DO NOT REPRODUCE OR DISCLOSE TO
OTHERS WITHOUT EXPRESS WRITTEN
CONSENT OF INV/DYNATEC.

REVISIONS					
REV.	BY	DESCRIPTION	DATE	BY	APPROVED

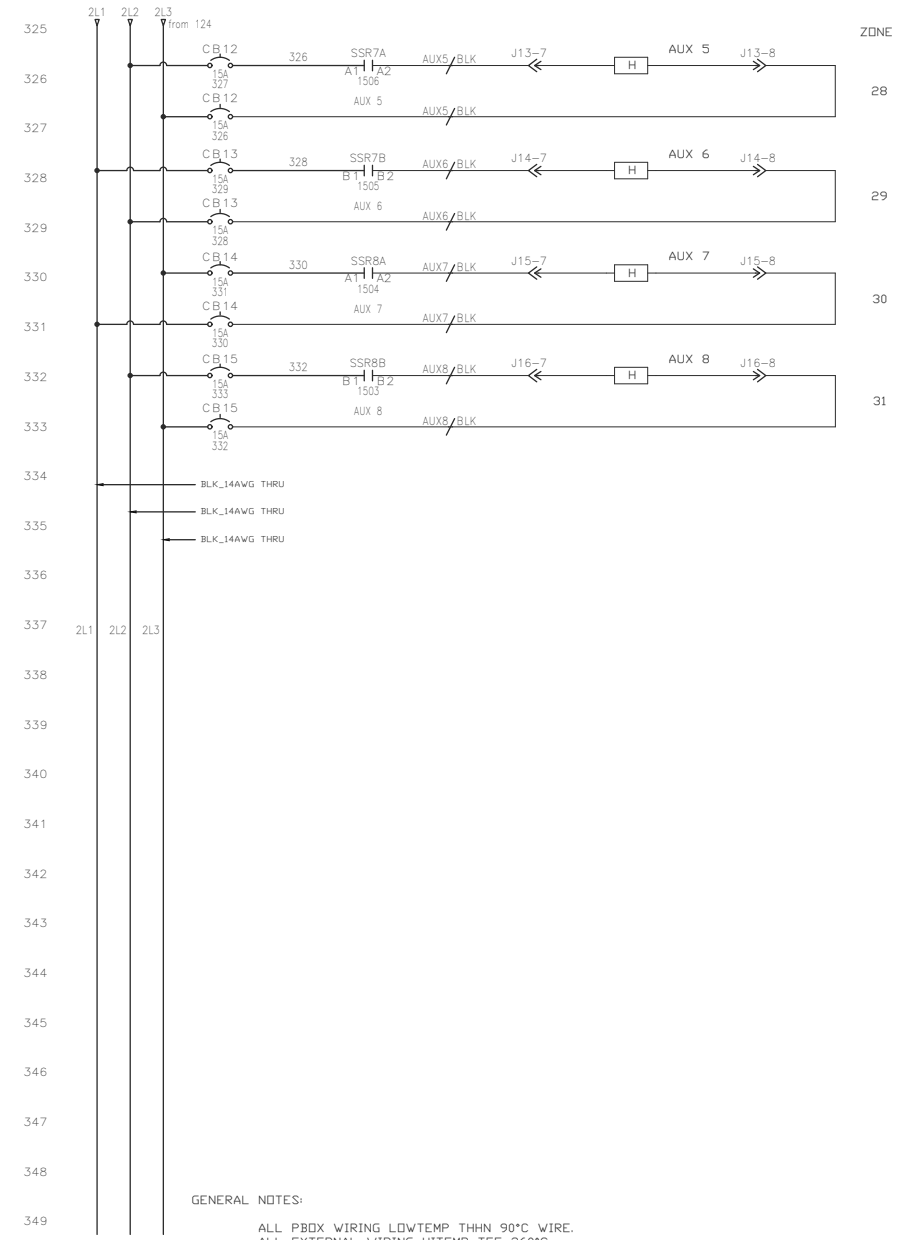
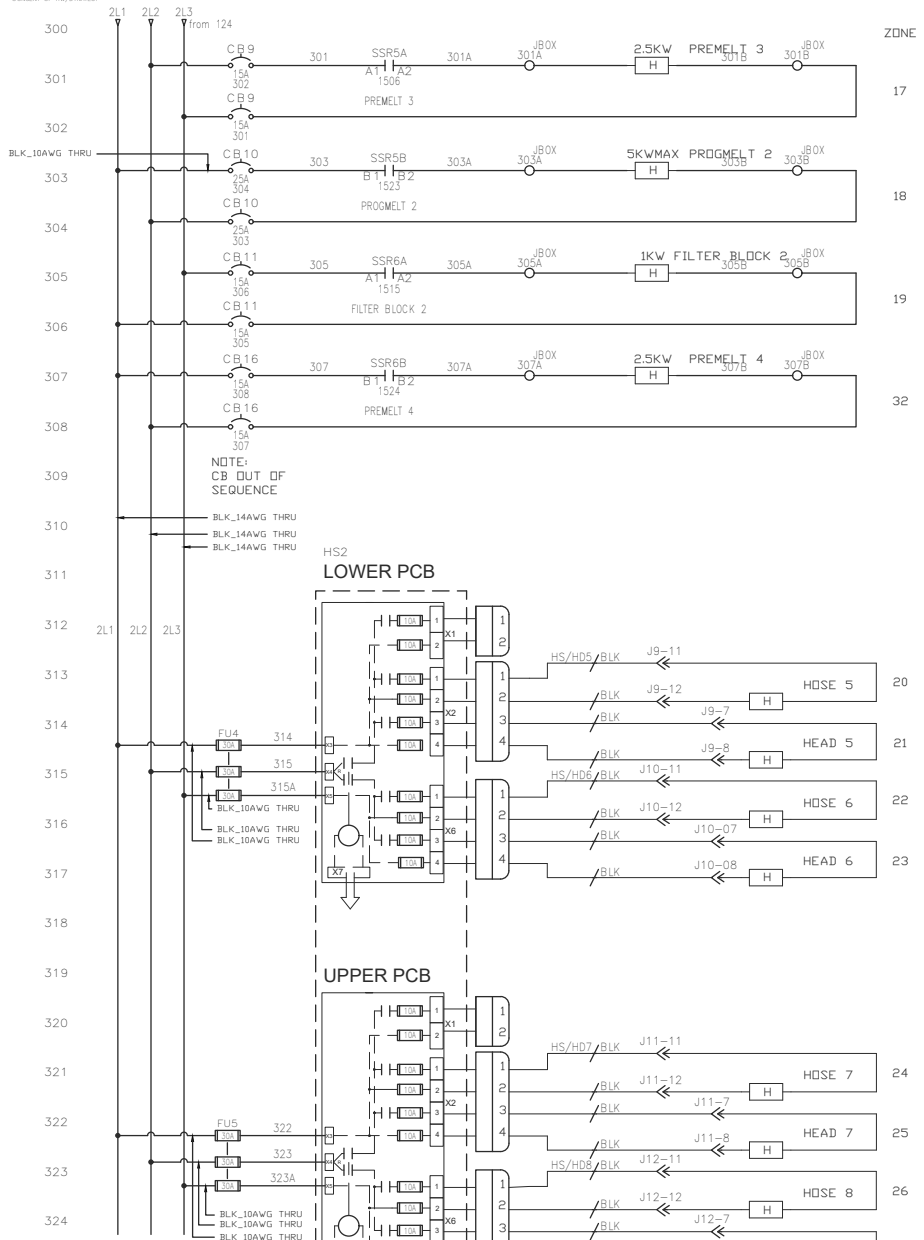

GENERAL NOTES:

- ALL PBOX WIRING LOWTEMP THHN 90°C WIRE.
- ALL EXTERNAL WIRING HITEMP TFE 260°C OR EQUIV.
- DENOTES TERMINAL IN PBOX
- DENOTES TERMINAL IN JBOX
- APPLY WIRE NUMBERS TO BOTH ENDS OF WIRE.
- DENOTES DEVICE EXTERNAL TO PBOX.
- WIRE ALL GROUND CONNECTIONS PER DRAWING 804704.
- THIS IS A GENERAL SCHEMATIC. NOT ALL DEVICES MAY BE PRESENT. SEE ORDER FOR NUMBER OF HOSES, HEADS, AUX, AND MOTORS.

ITEM	PART NUMBER	QTY	UOM	DESCRIPTION
PARTS LIST				
TOLERANCES (UNLESS OTHERWISE SPECIFIED)				
DO NOT SCALE DRAWING		STATUS		DESIGN
COMPUTER DESCRIPTIONS (CHARACTERS)		NEXT ASSY		SCALE: DRAWN BY: CHECKED BY: APP'D BY:
FOR MACHINING STANDARDS AND DIMENSIONS, SEE INV/DYNATEC SPEC. A03539		SOURCE		DATE: 10.07.13 SHEET 3 OF SHEETS 18 DRAWING NO. 821067



TITLE: V6, M210, 240V, DH HEATER CIRCUITS

THIS DRAWING IS THE PROPERTY OF IN/DRAMATEC.
DO NOT REPRODUCE OR DISCLOSE TO
OTHERS WITHOUT EXPRESS WRITTEN
CONSENT OF IN/DRAMATEC.

REVISIONS					
REV.	BY	DESCRIPTION	DATE	BY	APPROVED

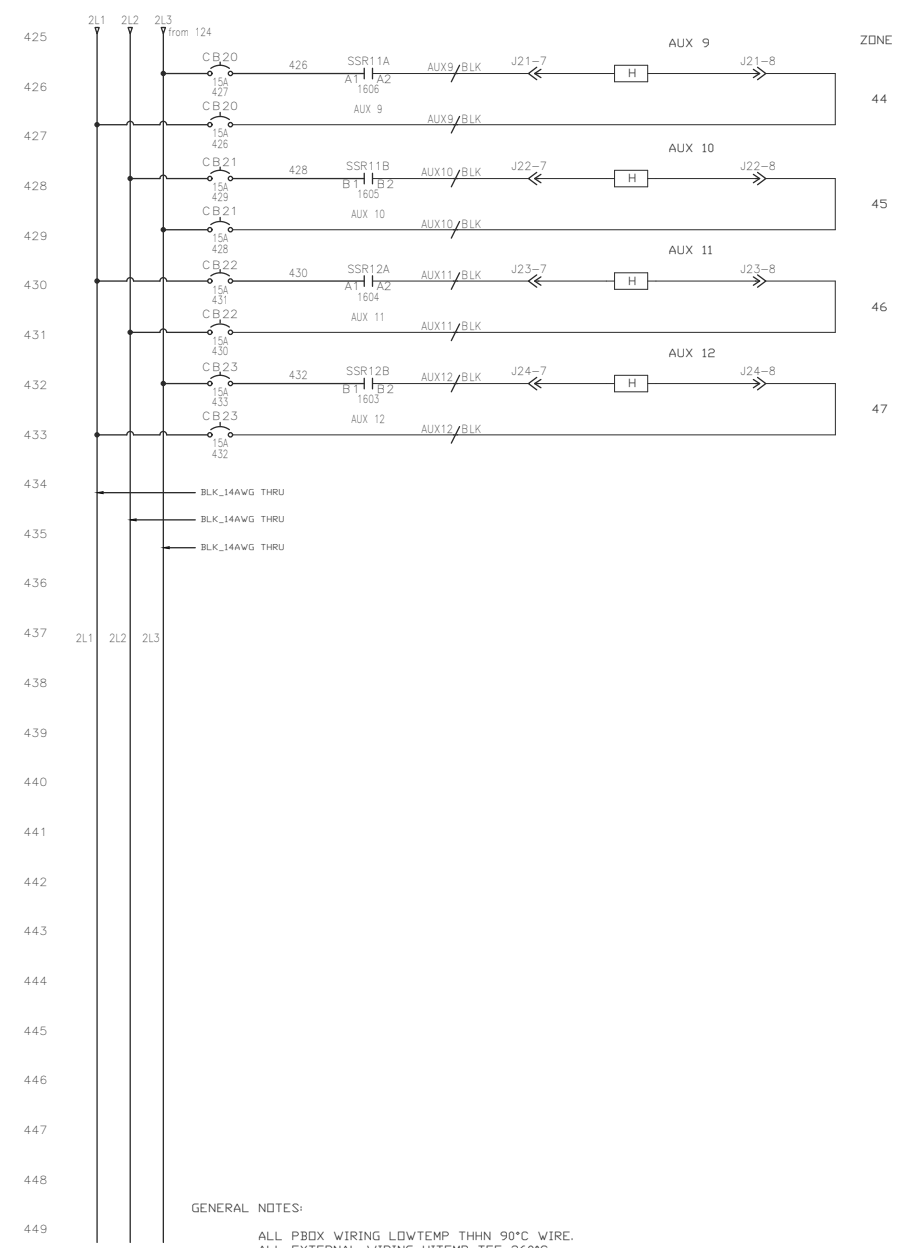
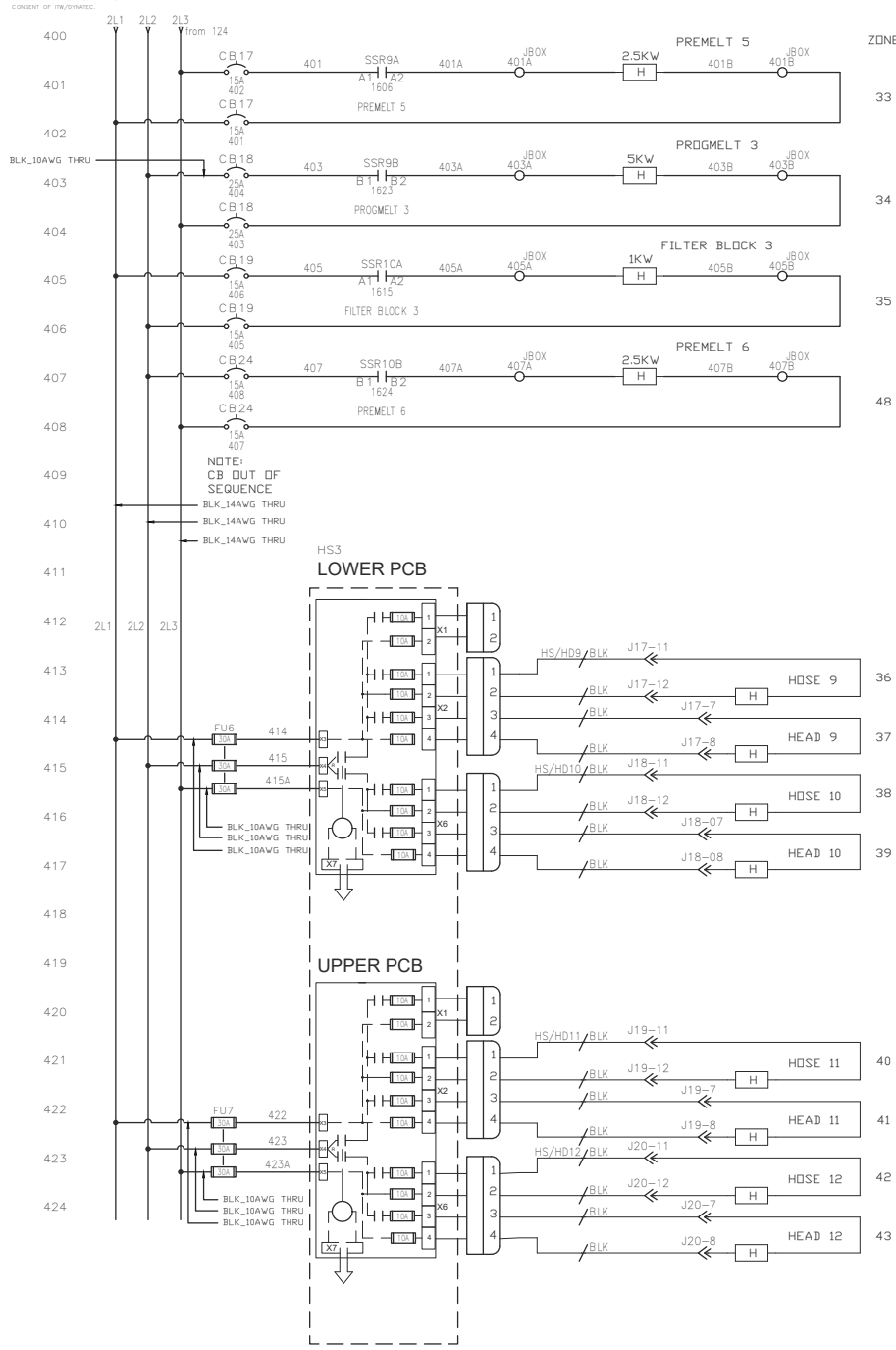

GENERAL NOTES:

- ALL PBOX WIRING LOWTEMP THHN 90°C WIRE.
- ALL EXTERNAL WIRING HITEMP TFE 260°C OR EQUIV.
- DENOTES TERMINAL IN PBOX
- DENOTES TERMINAL IN JBOX
- APPLY WIRE NUMBERS TO BOTH ENDS OF WIRE.
- DENOTES DEVICES EXTERNAL TO PBOX.
- WIRE ALL GROUND CONNECTIONS PER DRAWING 804704.
- THIS IS A GENERAL SCHEMATIC. NOT ALL DEVICES MAY BE PRESENT. SEE ORDER FOR NUMBER OF HOSES, HEADS, AUX, AND MOTORS.

ITEM	PART NUMBER	QTY	UOM	DESCRIPTION
PARTS LIST				
TOLERANCES (UNLESS OTHERWISE SPECIFIED)				
DO NOT SCALE DRAWING		STATUS		ISS
COMPUTER DESCRIPTIONS (CHARACTERS)		NEXT ASSY		SCALE: DRAWN BY: CHECKED BY: APP'D BY:
FOR MACHINING STANDARDS AND DIMENSIONS, SEE IN/DRAMATEC SPEC. ADRS09		SOURCE		REV. DATE: 10.07.13 SHEET 4 OF SHEETS 18 DRAWING NO. 821067



TITLE: V6, M210, 240V, DH HEATER CIRCUITS

THIS DRAWING IS THE PROPERTY OF INVA/DYNATEC. DO NOT REPRODUCE OR DISCLOSE TO OTHERS WITHOUT EXPRESS WRITTEN CONSENT OF INVA/DYNATEC.

REV.	BY	DATE	BY	APPROVED

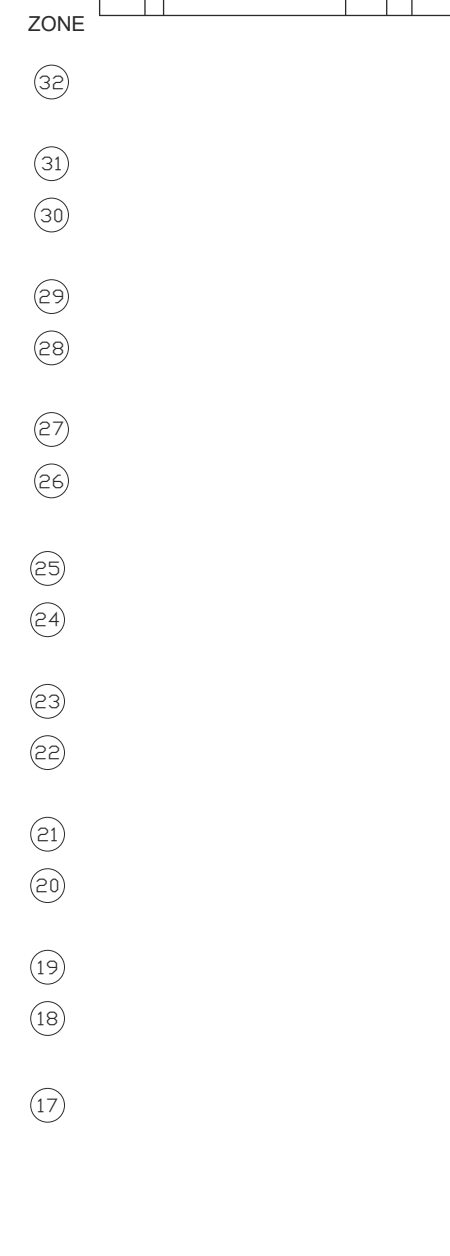
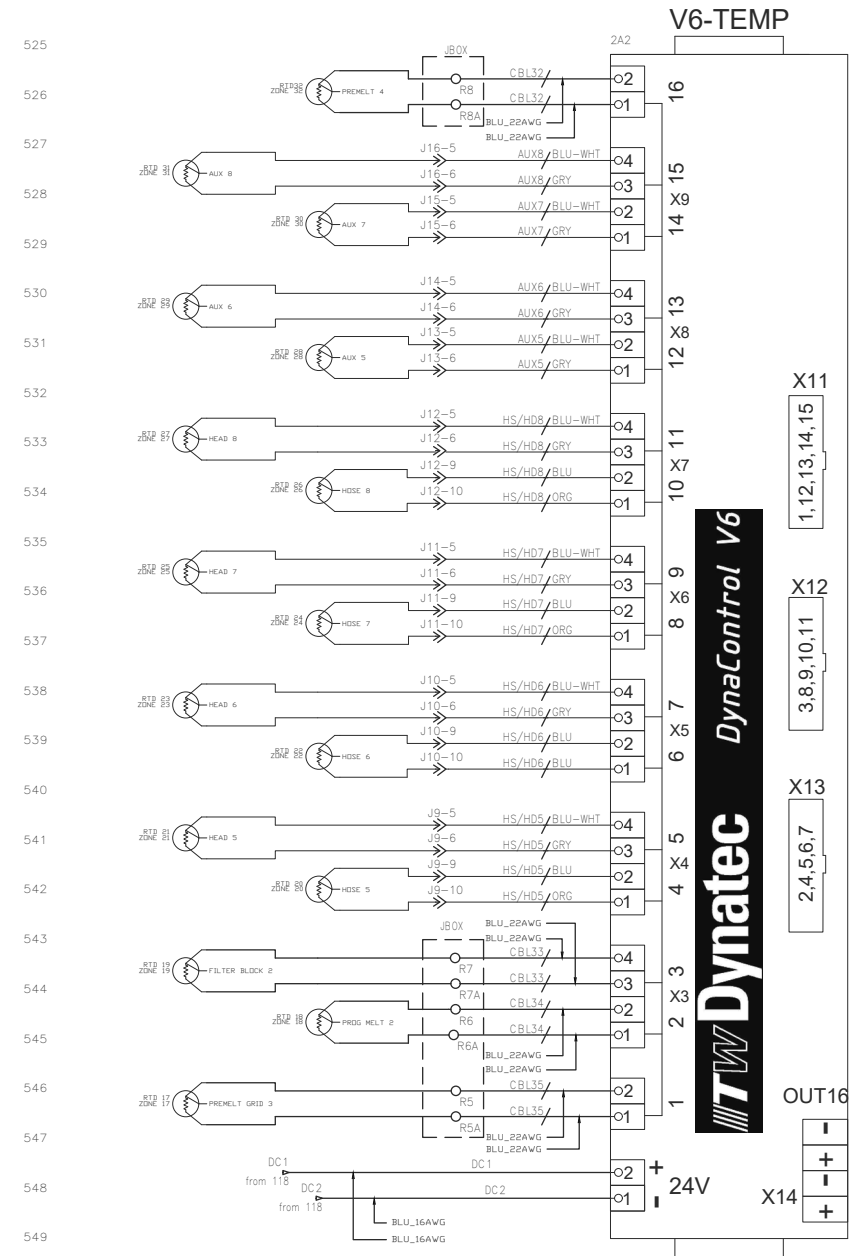
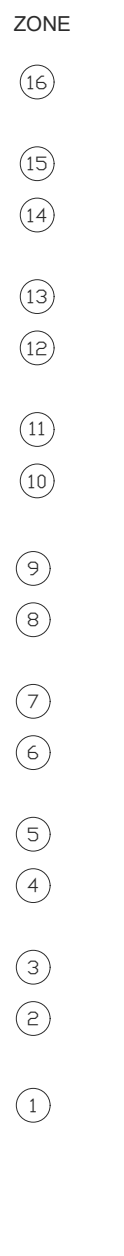
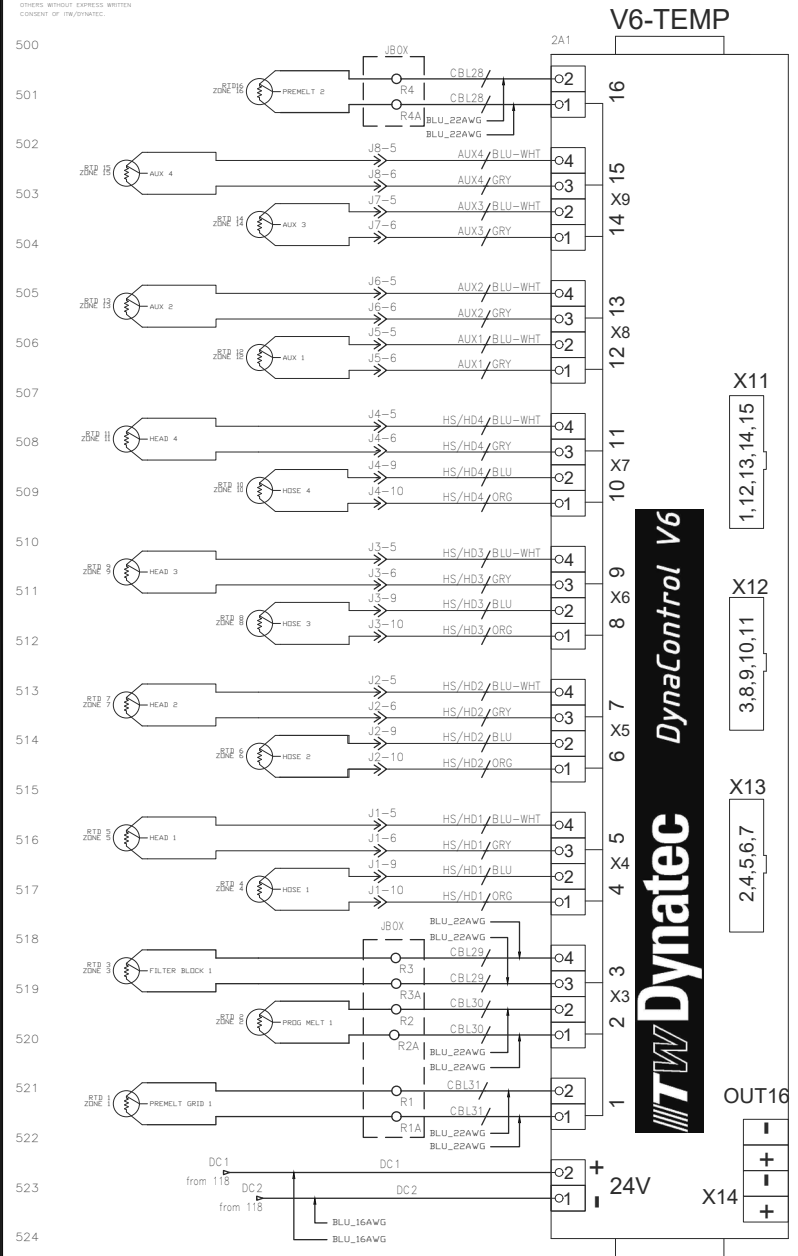

ITEM	PART NUMBER	QTY	UOM	DESCRIPTION

DO NOT SCALE DRAWING NEXT ASSY		TOLERANCES (UNLESS OTHERWISE SPECIFIED) Dynatec R10 UNLESS OTHERWISE SPECIFIED	
		STATUS: T	DRAWN BY: BFO
COMPUTER DESCRIPTIONS (CHARACTERS) FOR MACHINING STANDARDS AND DIMENSIONS INV/CHARTER-2000C ADDISON		DATE: 10.07.13	CHECKED BY: ---
SOURCE: T	TITLE: V6_M210_240V_DH RTD INPUTS	SHEET: 5	OF SHEETS: 18
DATE: 10.07.13		DRAWING NO: 821067	

THIS DRAWING IS THE PROPERTY OF ITW/DYNATEC.
DO NOT REPRODUCE OR DISCLOSE TO
OTHERS WITHOUT EXPRESS WRITTEN
CONSENT OF ITW/DYNATEC.

REVISIONS					
REV.	BY	DESCRIPTION	DATE	BY	APPROVED

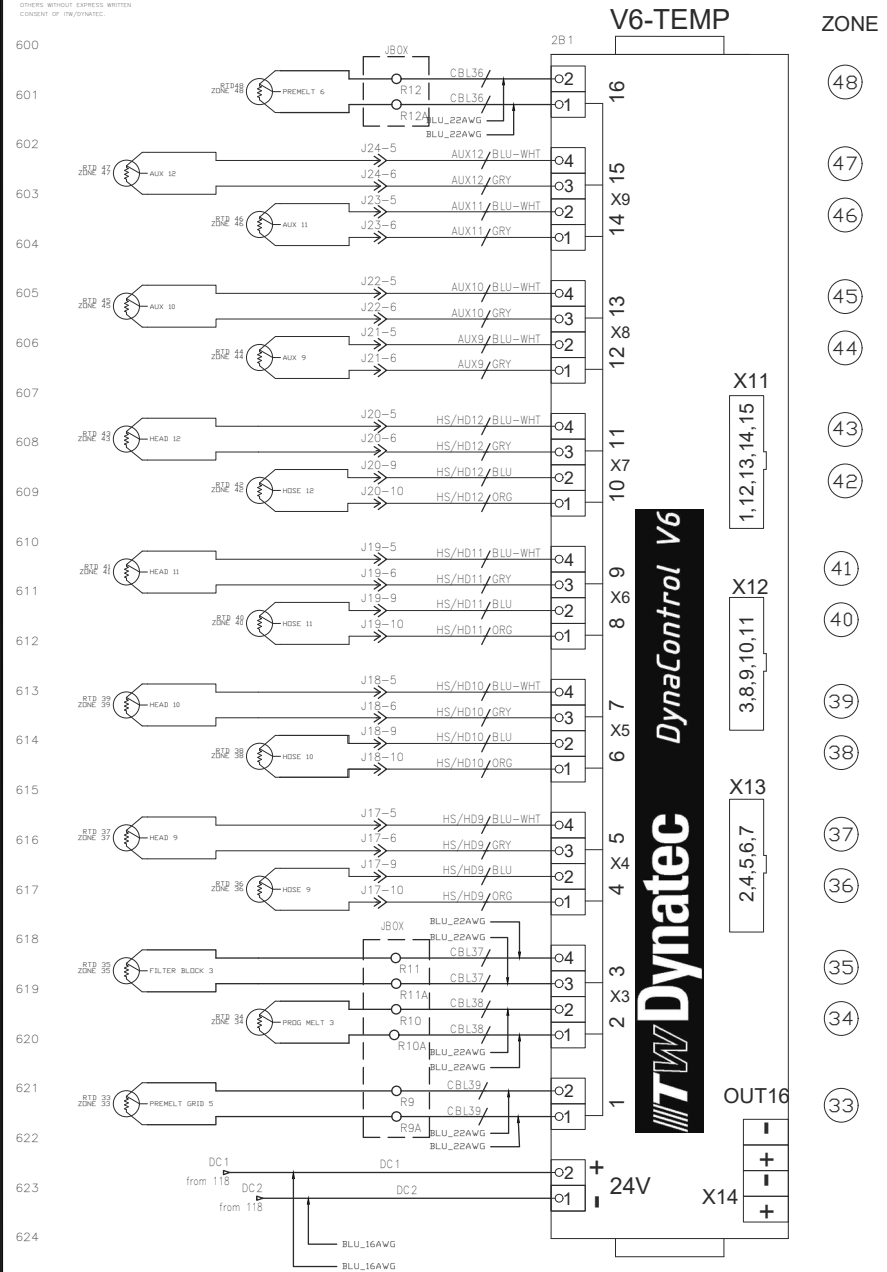

- (48)
- (47)
- (46)
- (45)
- (44)
- (43)
- (42)
- (41)
- (40)
- (39)
- (38)
- (37)
- (36)
- (35)
- (34)
- (33)

ITEM	PART NUMBER	QTY	UOM	DESCRIPTION														
PARTS LIST																		
DO NOT SCALE DRAWING				<table border="1"> <tr> <td>STATUS</td> <td>DES</td> <td>DATE</td> <td>SCALE</td> <td>DRAWN BY</td> <td>CHECKED BY</td> <td>APP'D BY</td> </tr> <tr> <td>T</td> <td></td> <td>10.07.13</td> <td>BFO</td> <td></td> <td></td> <td></td> </tr> </table>	STATUS	DES	DATE	SCALE	DRAWN BY	CHECKED BY	APP'D BY	T		10.07.13	BFO			
STATUS	DES	DATE	SCALE	DRAWN BY	CHECKED BY	APP'D BY												
T		10.07.13	BFO															
FOR MACHINING STANDARDS AND DIMENSIONS, SEE ITW/DYNATEC SPEC. APPROX.				<table border="1"> <tr> <td>SHEET</td> <td>OF SHEETS</td> <td>DRAWING NO.</td> </tr> <tr> <td>6</td> <td>18</td> <td>821067</td> </tr> </table>	SHEET	OF SHEETS	DRAWING NO.	6	18	821067								
SHEET	OF SHEETS	DRAWING NO.																
6	18	821067																

THIS DRAWING IS THE PROPERTY OF INVA/DYNATEC.
DO NOT REPRODUCE OR DISCLOSE TO
OTHERS WITHOUT EXPRESS WRITTEN
CONSENT OF INVA/DYNATEC.

REVISIONS				
REV.	BY	DESCRIPTION	DATE	APP'D BY

700
701
702
703
704
705
706
707
708
709
710
711
712
713
714
715
716
717
718
719
720
721
722
723
724

HOPPER A V6-BASE

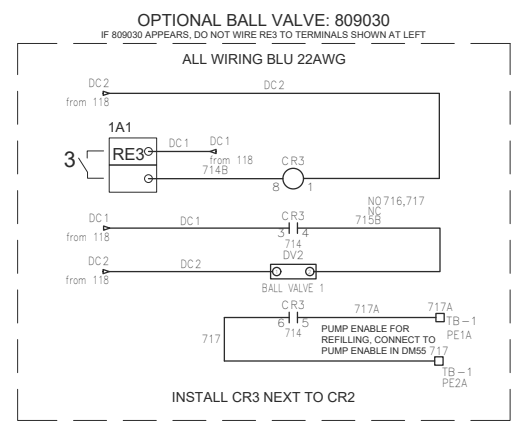
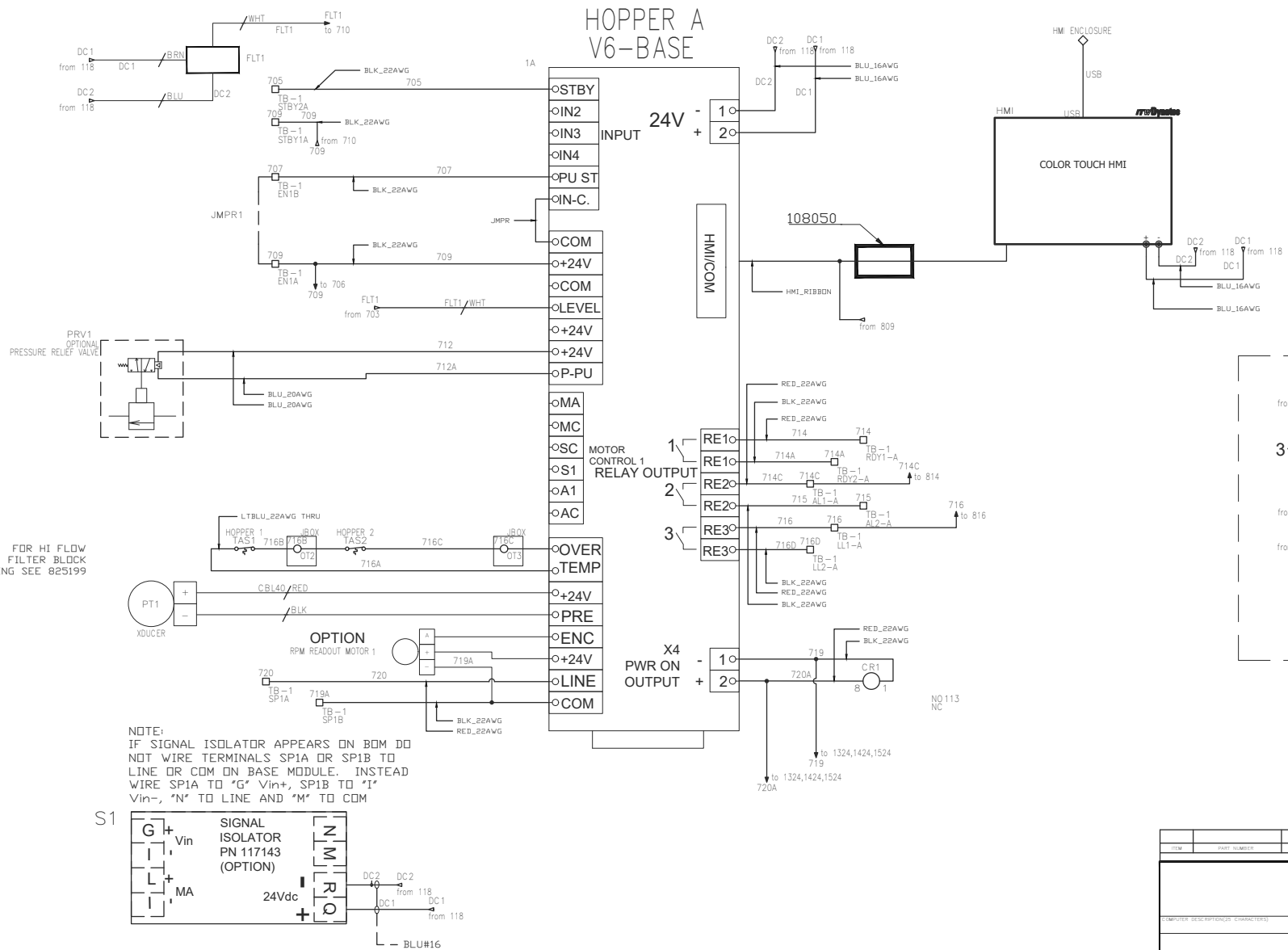

NOTE:
IF SIGNAL ISOLATOR APPEARS ON BOM DO
NOT WIRE TERMINALS SP1A OR SP1B TO
LINE OR COM ON BASE MODULE. INSTEAD
WIRE SP1A TO 'G' Vin+, SP1B TO 'I'
Vin-, 'N' TO LINE AND 'M' TO COM

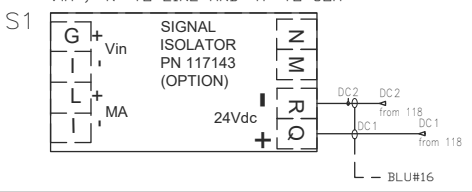

ITEM	PART NUMBER	QTY	UOM	DESCRIPTION

DO NOT SCALE DRAWING		TOLERANCES (UNLESS OTHERWISE SPECIFIED)			
COMPUTER DESCRIPTIONS (CHARACTERS)		NEXT ASSY		V6, M210, 240V, DH BASE MODULE	
FOR MACHINING STANDARDS AND DIMENSIONS, SEE INVA/DYNATEC SPEC. APPEND		SCALE:	DRAWN BY:	CHECKED BY:	APP'D BY:
		T	BFG	---	---
		DATE:	SHEET	OF SHEETS	DRAWING NO.
		10.07.13	7	18	821067

REVISIONS					
REV.	BY	DESCRIPTION	DATE	BY	APPROVED

THIS DRAWING IS THE PROPERTY OF ITW/DYNATEC.
DO NOT REPRODUCE OR DISCLOSE TO
OTHERS WITHOUT EXPRESS WRITTEN
CONSENT OF ITW/DYNATEC.

800
801
802
803
804
805
806
807
808
809
810
811
812
813
814
815
816
817
818
819
820
821
822
823
824

HOPPER B V6-BASE

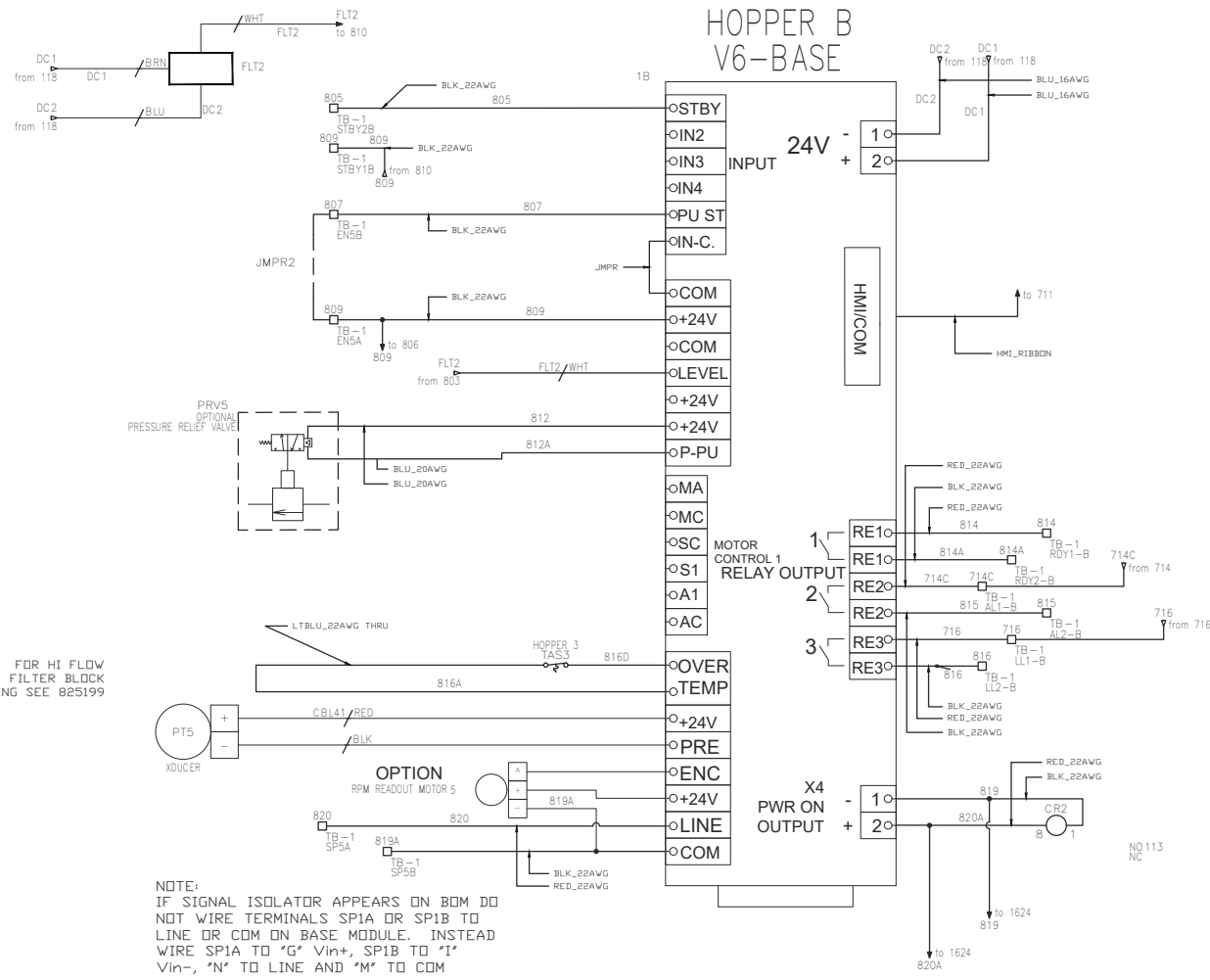

FOR HI FLOW
FILTER BLOCK
WIRING SEE 825199

NOTE:
IF SIGNAL ISOLATOR APPEARS ON BOM DO
NOT WIRE TERMINALS SP1A OR SP1B TO
LINE OR COM ON BASE MODULE. INSTEAD
WIRE SP1A TO 'G' Vin+, SP1B TO 'I'
Vin-, 'N' TO LINE AND 'M' TO COM

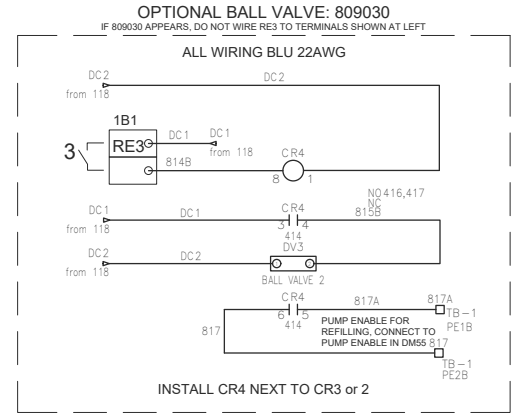
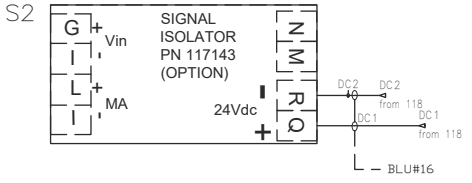

ITEM	PART NUMBER	QTY	UOM	DESCRIPTION

DO NOT SCALE DRAWING		TOLERANCES (UNLESS OTHERWISE SPECIFIED)			
COMPUTER DESCRIPTIONS (CHARACTERS)	NEXT ASSY	STATUS	REV	SCALE:	TITLE: V6, M210, 240V, DH BASE MODULE
FOR MACHINING STANDARDS AND DIMENSIONS, SEE ITW/DYNATEC SPEC. A03509	DATE: 10.07.13	SHEET 8	OF SHEETS 18	DRAWN BY: BFG	CHECKED BY: --- APPROVED BY: ---
					DRAWING NO: 821067

THIS DRAWING IS THE PROPERTY OF ITW/DYNATEC.
DO NOT REPRODUCE OR DISCLOSE TO
OTHERS WITHOUT EXPRESS WRITTEN
CONSENT OF ITW/DYNATEC.

REVISIONS					
REV.	BY	DESCRIPTION	DATE	BY	APPROVED

900

901

902

903

904

905

906

907

908

909

910

911

912

913

914

915

916

917

918

919

920

921

922

923

924

MOTOR CONTROL MODULE

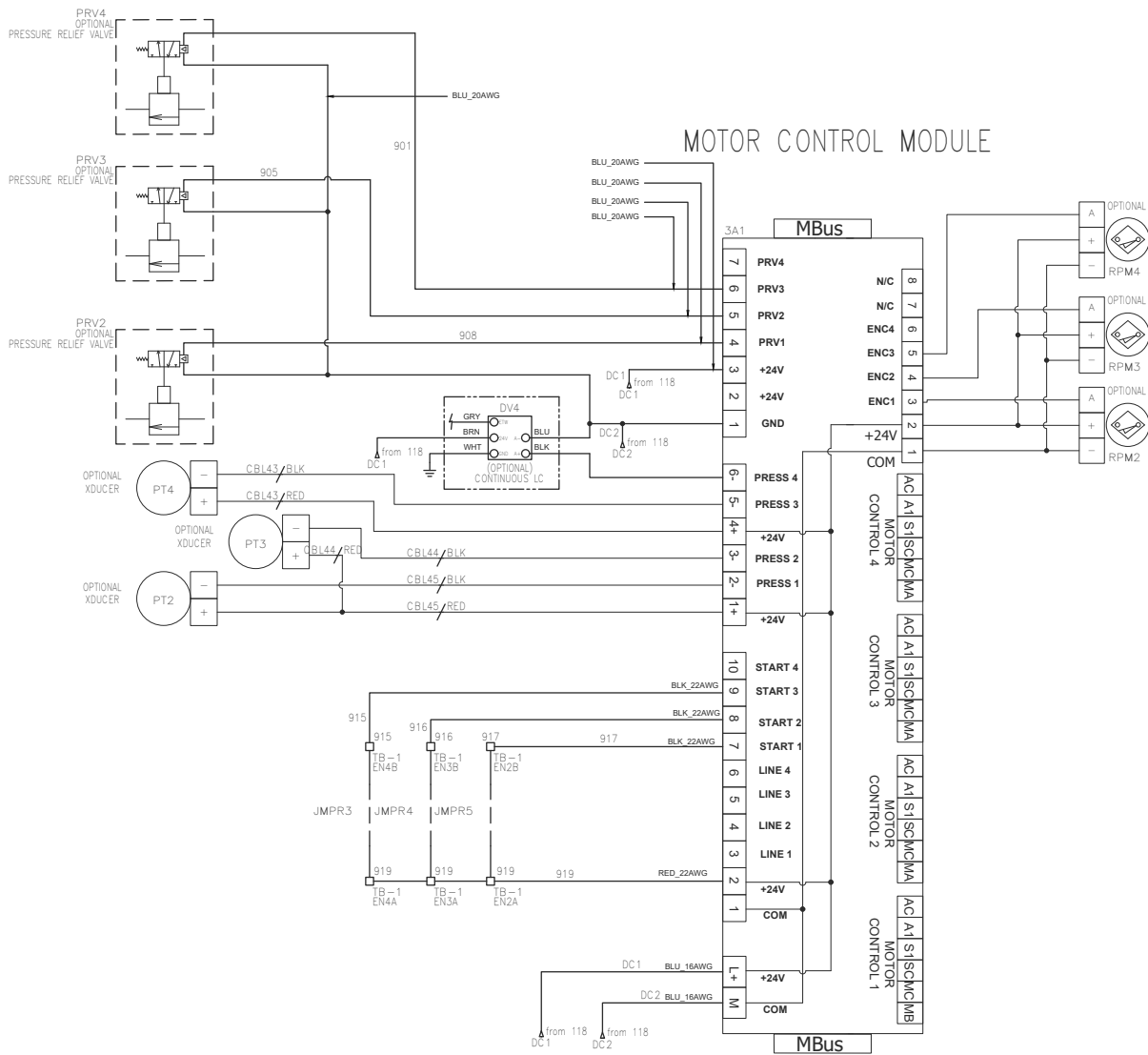

GENERAL NOTES:

- ALL PBOX WIRING LOWTEMP THHN 90°C WIRE.
- ALL EXTERNAL WIRING HITEMP TFE 260°C OR EQUIV.
- DENOTES TERMINAL IN PBOX
- DENOTES TERMINAL IN JBOX
- APPLY WIRE NUMBERS TO BOTH ENDS OF WIRE.
- DENOTES DEVICES EXTERNAL TO PBOX.
- - - - - DENOTES WIRING TO BE DONE BY OTHER/NOT INCLUDED.
- WIRE ALL GROUND CONNECTIONS PER DRAWING 804704
- THIS IS A GENERAL SCHEMATIC. NOT ALL DEVICES MAY BE PRESENT. SEE ORDER FOR NUMBER OF HOSES, HEADS, AUX. AND MOTORS.

ITEM	PART NUMBER	QTY	UOM	DESCRIPTION																								
PARTS LIST																												
<table border="1"> <tr> <td colspan="2">DO NOT SCALE DRAWING</td> <td colspan="2">TOLERANCES (UNLESS OTHERWISE SPECIFIED)</td> <td colspan="2"> </td> </tr> <tr> <td colspan="2">COMPUTER DESCRIPTIONS (CHARACTERS)</td> <td colspan="2">NEXT ASSY</td> <td colspan="2"> TITLE: V6, M210, 240V, DH PRESSURE INPUTS </td> </tr> <tr> <td colspan="2">FOR MACHINING STANDARDS AND DIMENSIONS, SEE ITW/DYNATEC SPEC. A03509</td> <td colspan="2">SOURCE</td> <td colspan="2"> SCALE: B/FQ DATE: 10.07.13 </td> </tr> <tr> <td colspan="2"></td> <td colspan="2">REV. T</td> <td colspan="2"> CHECKED BY: --- APPROVED BY: --- DRAWN BY: B/FQ SHEET: 9 OF SHEETS 18 DRAWING NO.: 821067 </td> </tr> </table>					DO NOT SCALE DRAWING		TOLERANCES (UNLESS OTHERWISE SPECIFIED)				COMPUTER DESCRIPTIONS (CHARACTERS)		NEXT ASSY		TITLE: V6, M210, 240V, DH PRESSURE INPUTS		FOR MACHINING STANDARDS AND DIMENSIONS, SEE ITW/DYNATEC SPEC. A03509		SOURCE		SCALE: B/FQ DATE: 10.07.13				REV. T		CHECKED BY: --- APPROVED BY: --- DRAWN BY: B/FQ SHEET: 9 OF SHEETS 18 DRAWING NO.: 821067	
DO NOT SCALE DRAWING		TOLERANCES (UNLESS OTHERWISE SPECIFIED)																										
COMPUTER DESCRIPTIONS (CHARACTERS)		NEXT ASSY		TITLE: V6, M210, 240V, DH PRESSURE INPUTS																								
FOR MACHINING STANDARDS AND DIMENSIONS, SEE ITW/DYNATEC SPEC. A03509		SOURCE		SCALE: B/FQ DATE: 10.07.13																								
		REV. T		CHECKED BY: --- APPROVED BY: --- DRAWN BY: B/FQ SHEET: 9 OF SHEETS 18 DRAWING NO.: 821067																								

REVISIONS					
REV.	BY	DESCRIPTION	DATE	BY	APPROVED

THIS DRAWING IS THE PROPERTY OF TRW/DYNATEC.
DO NOT REPRODUCE OR DISCLOSE TO
OTHERS WITHOUT EXPRESS WRITTEN
CONSENT OF TRW/DYNATEC.

1000
1001
1002
1003
1004
1005
1006
1007
1008
1009
1010
1011
1012
1013
1014
1015
1016
1017
1018
1019
1020
1021
1022
1023
1024

MOTOR CONTROL MODULE

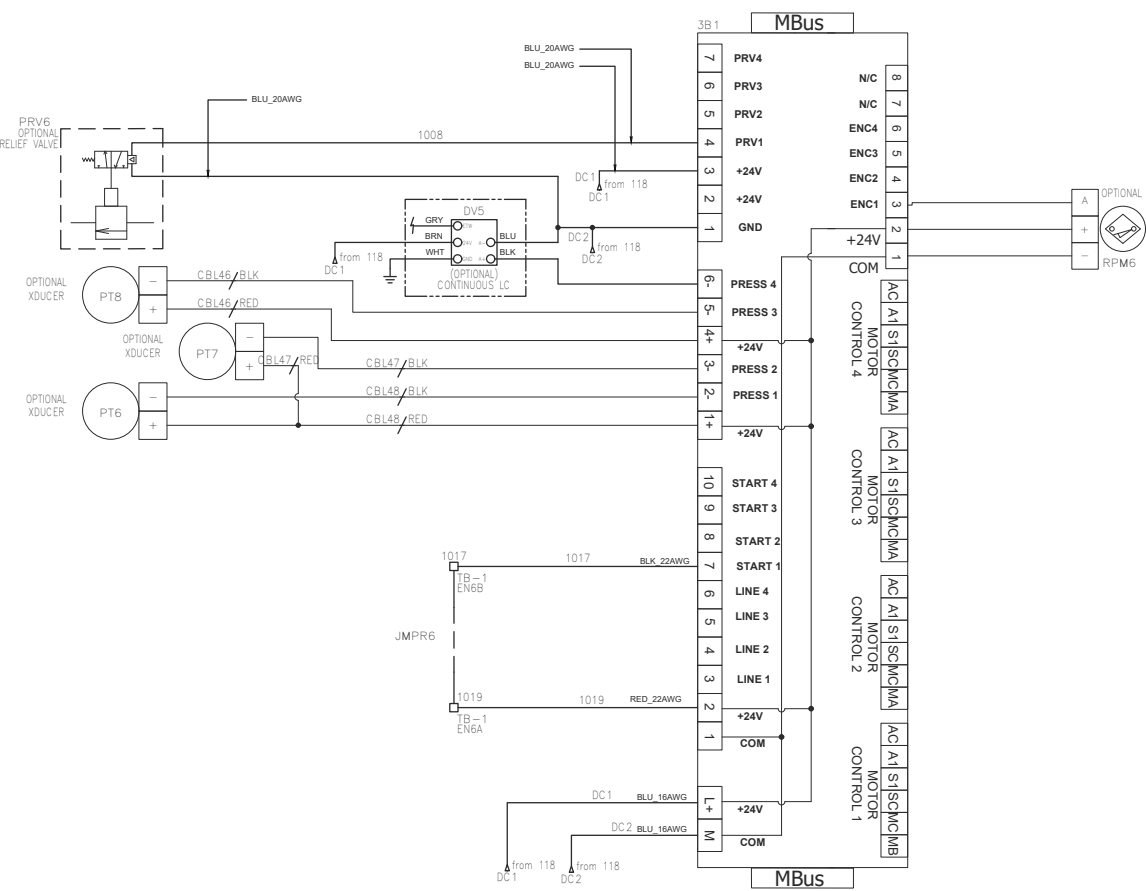

GENERAL NOTES:

- ALL PBOX WIRING LOWTEMP THHN 90°C WIRE.
- ALL EXTERNAL WIRING HITEMP TFE 260°C OR EQUIV.
- DENOTES TERMINAL IN PBOX
- DENOTES TERMINAL IN JBOX
- APPLY WIRE NUMBERS TO BOTH ENDS OF WIRE.
- DENOTES DEVICES EXTERNAL TO PBOX.
- DENOTES WIRING TO BE DONE BY OTHER/NOT INCLUDED.
- WIRE ALL GROUND CONNECTIONS PER DRAWING 804704
- THIS IS A GENERAL SCHEMATIC. NOT ALL DEVICES MAY BE PRESENT. SEE ORDER FOR NUMBER OF HOSES, HEADS, AUX. AND MOTORS.

ITEM	PART NUMBER	QTY	U/M	DESCRIPTION
PARTS LIST				



DO NOT SCALE DRAWING

FOR MACHINING STANDARDS AND DIMENSIONS, SEE TRW/DYNATEC SPEC. APPENDIX

DATE: 10.07.13

SHEET: 10 OF SHEETS 18

DRAWING NO.: 821067

TITLE: V6, M210, 240V, DH PRESSURE INPUTS

SCALE: B/FQ

CHECKED BY: ---

APPROVED BY: ---

REVISIONS					
REV.	BY	DESCRIPTION	DATE	BY	APPROVED

THIS DRAWING IS THE PROPERTY OF INW/DYNATEC.
DO NOT REPRODUCE OR DISCLOSE TO
OTHERS WITHOUT EXPRESS WRITTEN
CONSENT OF INW/DYNATEC.

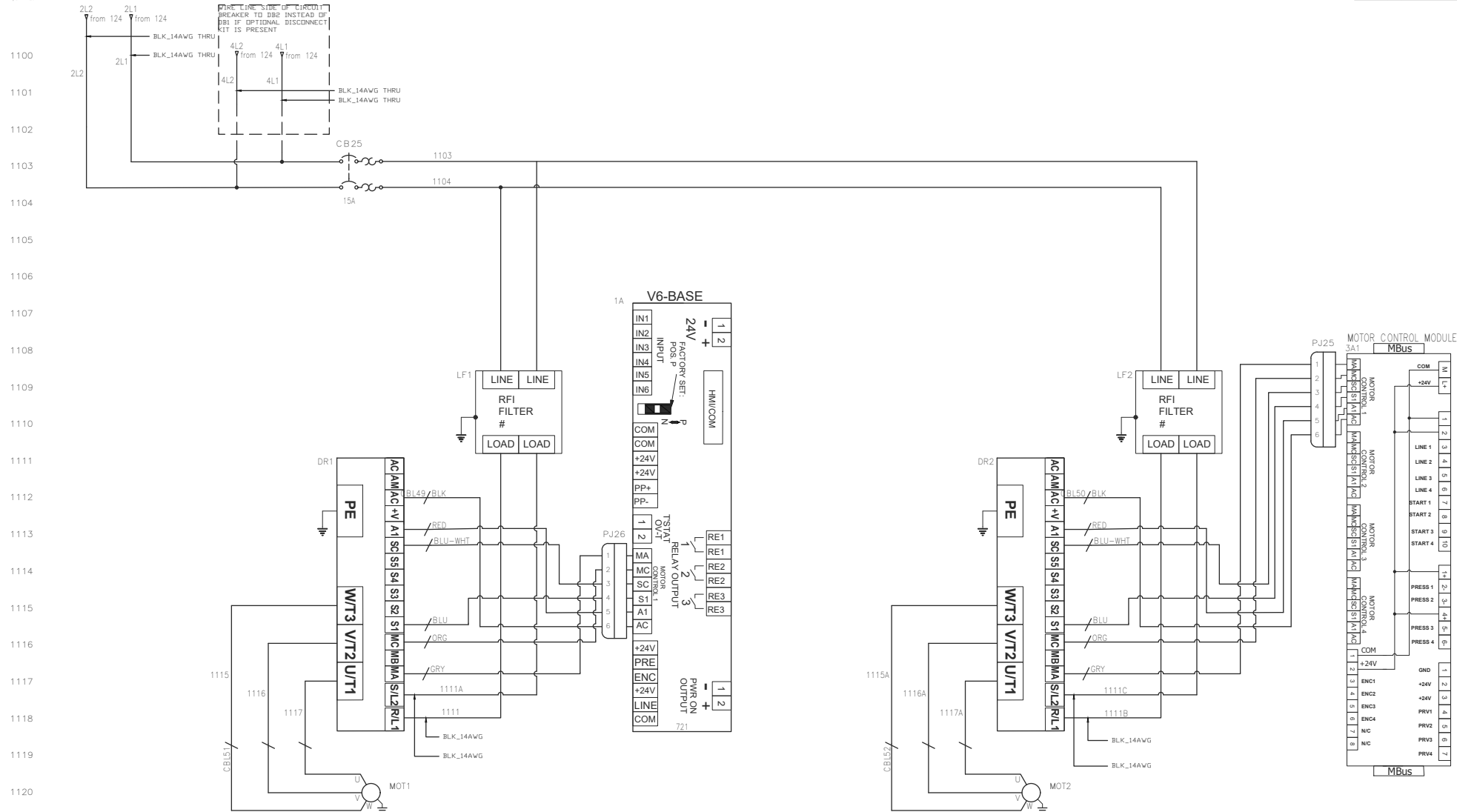

ITEM	PART NUMBER	QTY	U/M	PARTS LIST	DESCRIPTION

DO NOT SCALE DRAWING		REFERENCES (UNLESS OTHERWISE SPECIFIED)		 <small>MEMPHIS, TENNESSEE, TN</small>	
COMPUTER DESCRIPTIONS (CHARACTERS)	NEXT ASSY	STATUS	REV		
FOR MACHINING STANDARDS AND DIMENSIONS, SEE INW/DYNATEC SPEC. APPROX		SOURCE	T	SCALE:	TITLE: V6, M210, 240V, DH DRIVE INPUT
DATE:	10.07.13	DRAWN BY:	BFG	CHECKED BY:	---
SHEET:	11	OF SHEETS:	18	APPROV BY:	---
DRAWING NO.:			821067		

REVISIONS					
REV.	BY	DESCRIPTION	DATE	BY	APPROVED

THIS DRAWING IS THE PROPERTY OF RW/DYNATEC.
DO NOT REPRODUCE OR DISCLOSE TO
OTHERS WITHOUT EXPRESS WRITTEN
CONSENT OF RW/DYNATEC.

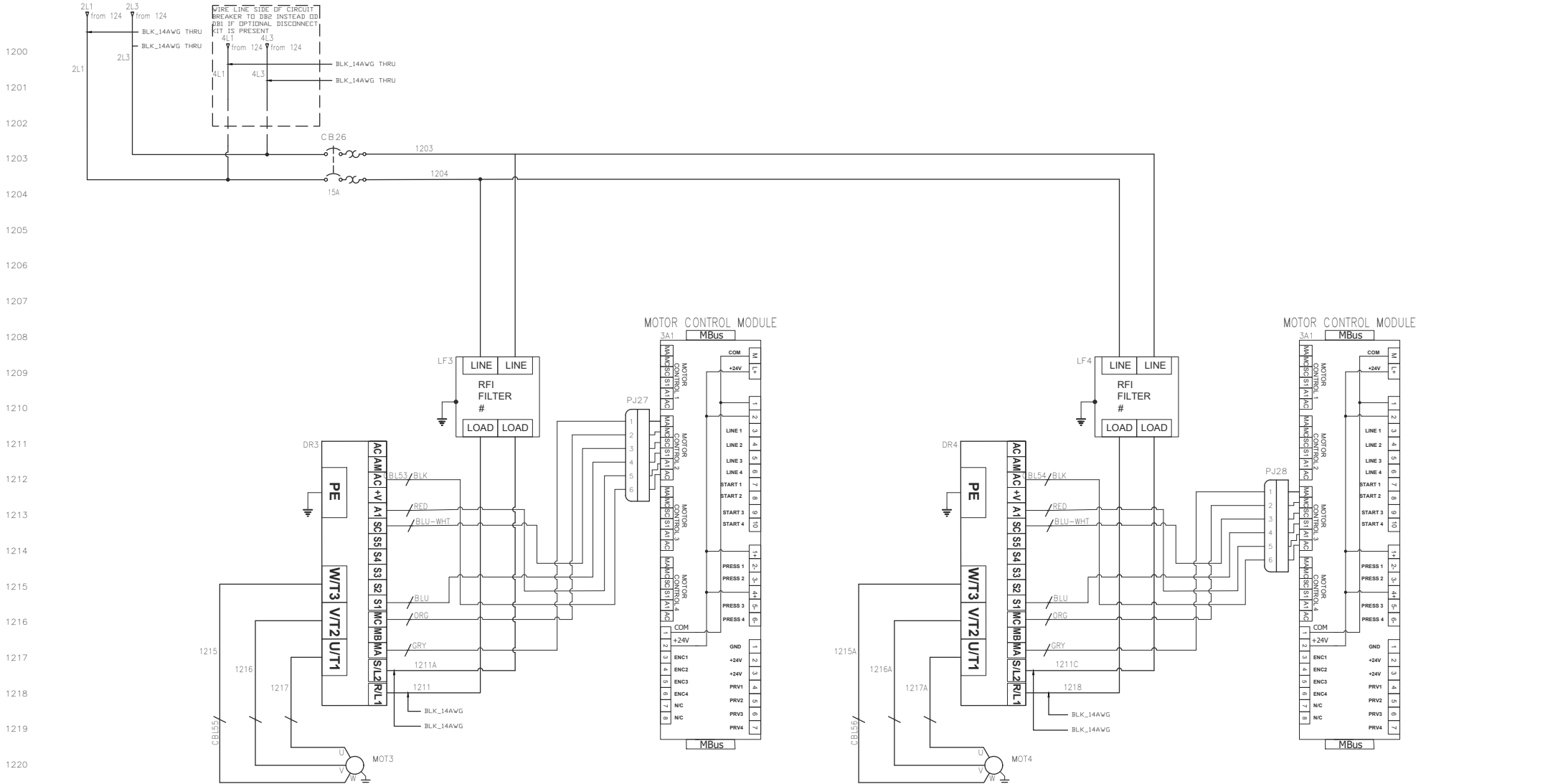

1200
1201
1202
1203
1204
1205
1206
1207
1208
1209
1210
1211
1212
1213
1214
1215
1216
1217
1218
1219
1220
1221
1222
1223
1224

ITEM	PART NUMBER	QTY	U/M	DESCRIPTION

DO NOT SCALE DRAWING		TOLERANCES (UNLESS OTHERWISE SPECIFIED)		Dynatec	
COMPUTER DESCRIPTIONS (CHARACTERS)		NEXT ASSY		TITLE: V6, M210, 240V, DH	
FOR MACHINING STANDARDS AND DIMENSIONS, SEE RW/DYNATEC SPEC. APPROV.		SOURCE		DRAWN BY: BFO	
DATE: 10.07.13		SHEET 12 OF SHEETS 18		CHECKED BY: ---	
				APPROV BY: ---	
				DRAWING NO: 821067	

REVISIONS					
REV.	BY	DESCRIPTION	DATE	BY	APPROVED

THIS DRAWING IS THE PROPERTY OF INVDYNATEC.
DO NOT REPRODUCE OR DISCLOSE TO
OTHERS WITHOUT EXPRESS WRITTEN
CONSENT OF INVDYNATEC.

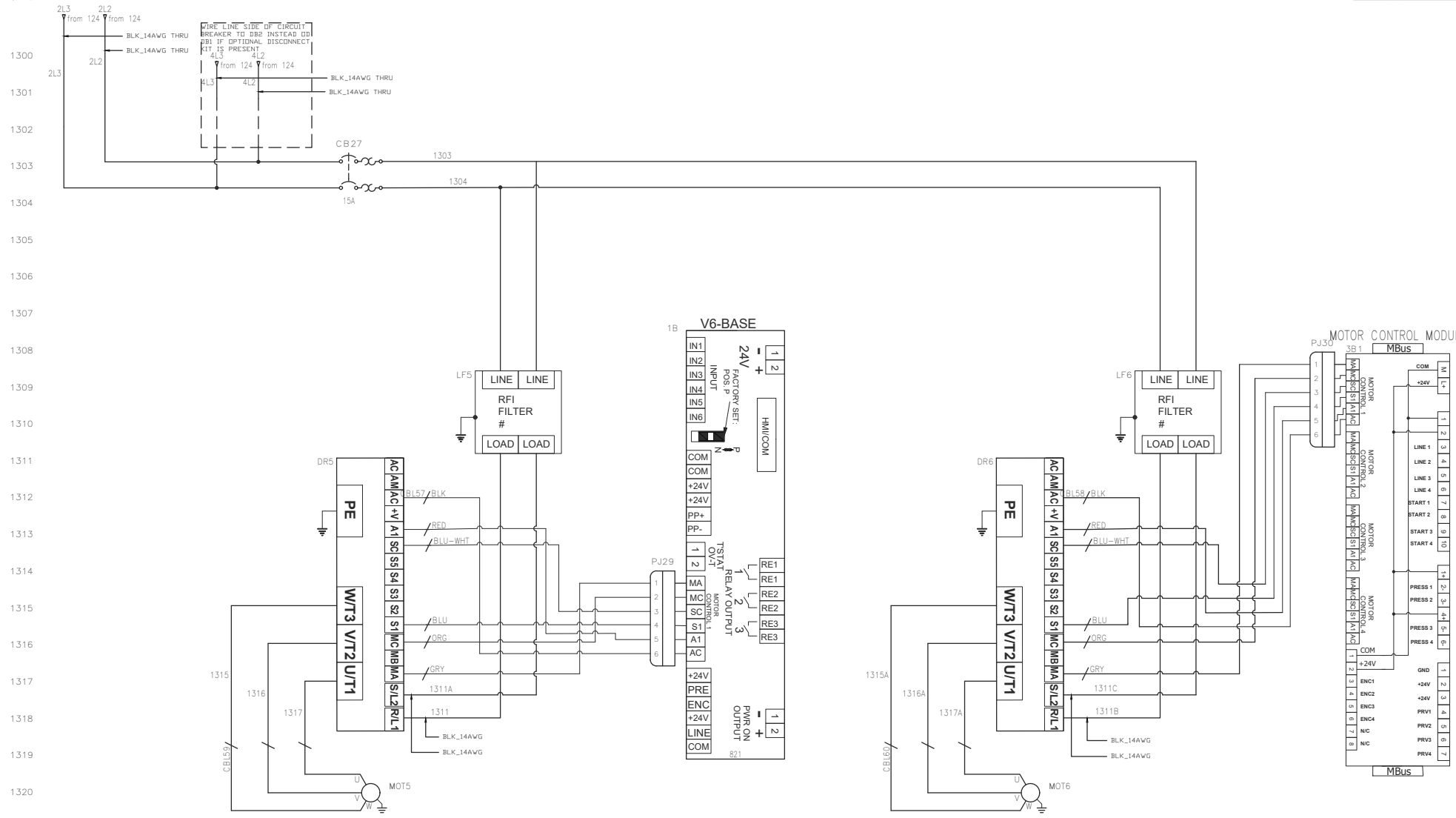

1300
1301
1302
1303
1304
1305
1306
1307
1308
1309
1310
1311
1312
1313
1314
1315
1316
1317
1318
1319
1320
1321
1322
1323
1324

ITEM	PART NUMBER	QTY	UOM	PARTS LIST	DESCRIPTION

DO NOT SCALE DRAWING		REFERENCES (UNLESS OTHERWISE SPECIFIED)		INVDYNATEC CORPORATION, HOUSTON, TX	
COMPUTER DESCRIPTIONS (CHARACTERS)	NEXT ASSY	STATUS	REV	TITLE: V6, M210, 240V, DH DRIVE INPUT	SCALE: 1:1
FOR MACHINING STANDARDS AND DIMENSIONS, SEE INVDYNATEC SPEC. APPROV.	SOURCE	DATE	TITLE	DRAWN BY: BFG	CHECKED BY: ---
		10.07.13			
				SHEET 13 OF SHEETS	DRAWING NO. 821067

REVISIONS					
REV.	REV.	DESCRIPTION	DATE	BY	APPROVED

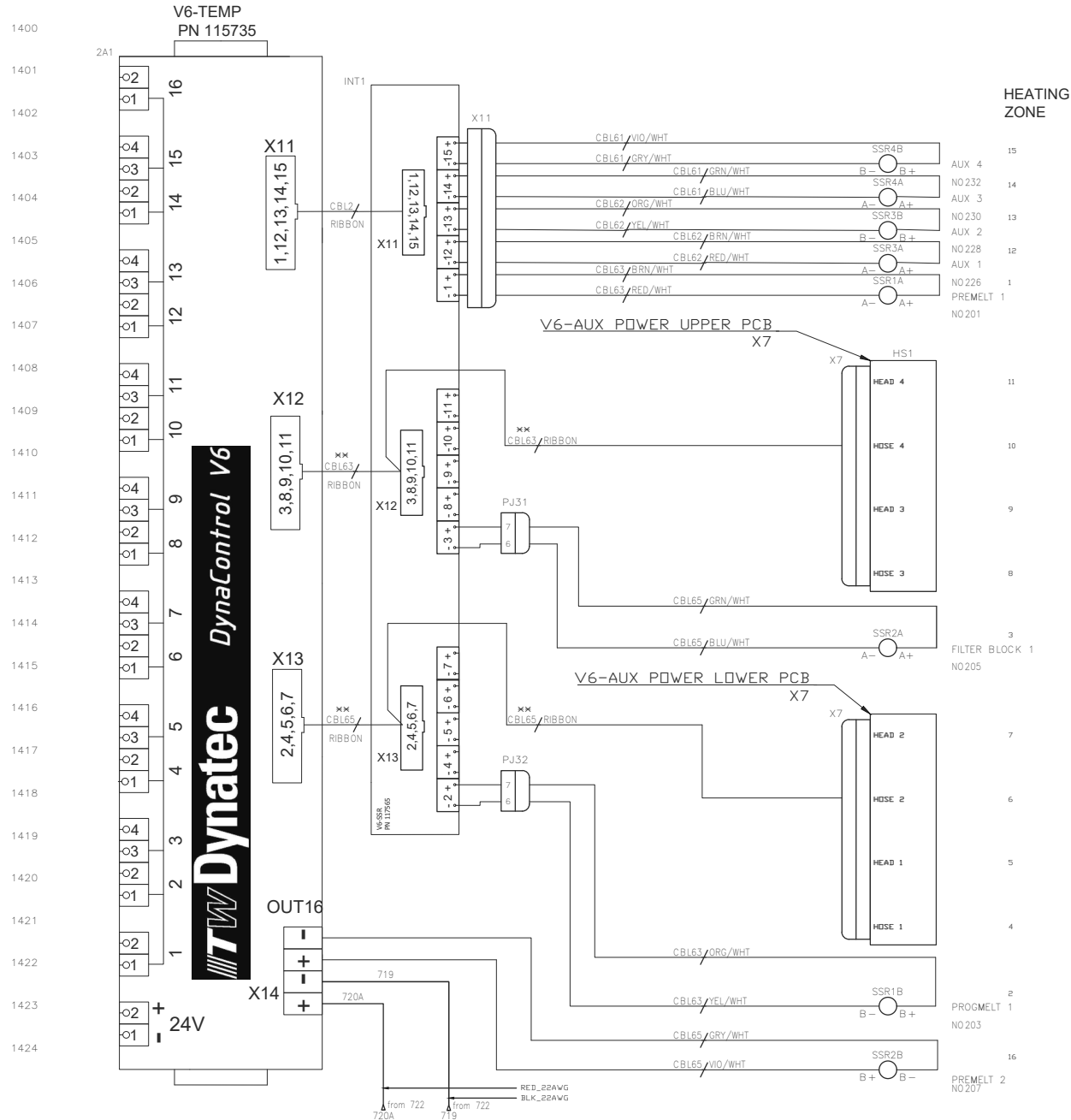

****NOTE**
 CONFIGURATION SHOWN IS FOR IS FOR A SYSTEM WITH FOUR OR MORE HOSE/HEAD CONNECTIONS REQUIRED WHERE CBL63 AND CBL65 ARE DUAL CABLES (P/N 823321). FOR A TWO HOSE/HEAD SYSTEM, CBL63 IS A SINGLE CABLE (P/N 823319) CONNECTED BETWEEN X12 ON V6-TEMP AND X12 ON INT1.

ITEM	PART NUMBER	QTY	UOM	DESCRIPTION

TOLERANCES (UNLESS OTHERWISE SPECIFIED) DIM: 0.01 ANG: 0.01 HOLE: 0.01 THREAD: AS PER ANSI FINISH: AS PER SPEC	TITLE: V6,M210,240V,DH SSR OUTPUTS DO NOT SCALE DRAWING NEXT ASSY:	STATUS: DES SCALE: BFO DATE: 10.07.13	DRAWN BY: --- CHECKED BY: --- APPO BY: --- SHEET: 14 OF 18 SHEETS
--	--	--	---

Dynatec
ITW (INDUSTRIAL TECHNOLOGICAL WORLD)
 WARRICK, IN 46786-1099, USA

DRAWING NO: **821067**

THIS DRAWING IS THE PROPERTY OF ITW/DYNATEC.
DO NOT REPRODUCE OR DISCLOSE TO
OTHERS WITHOUT EXPRESS WRITTEN
CONSENT OF ITW/DYNATEC.

REVISIONS					
REV.	BY	DESCRIPTION	DATE	BY	APPROVED

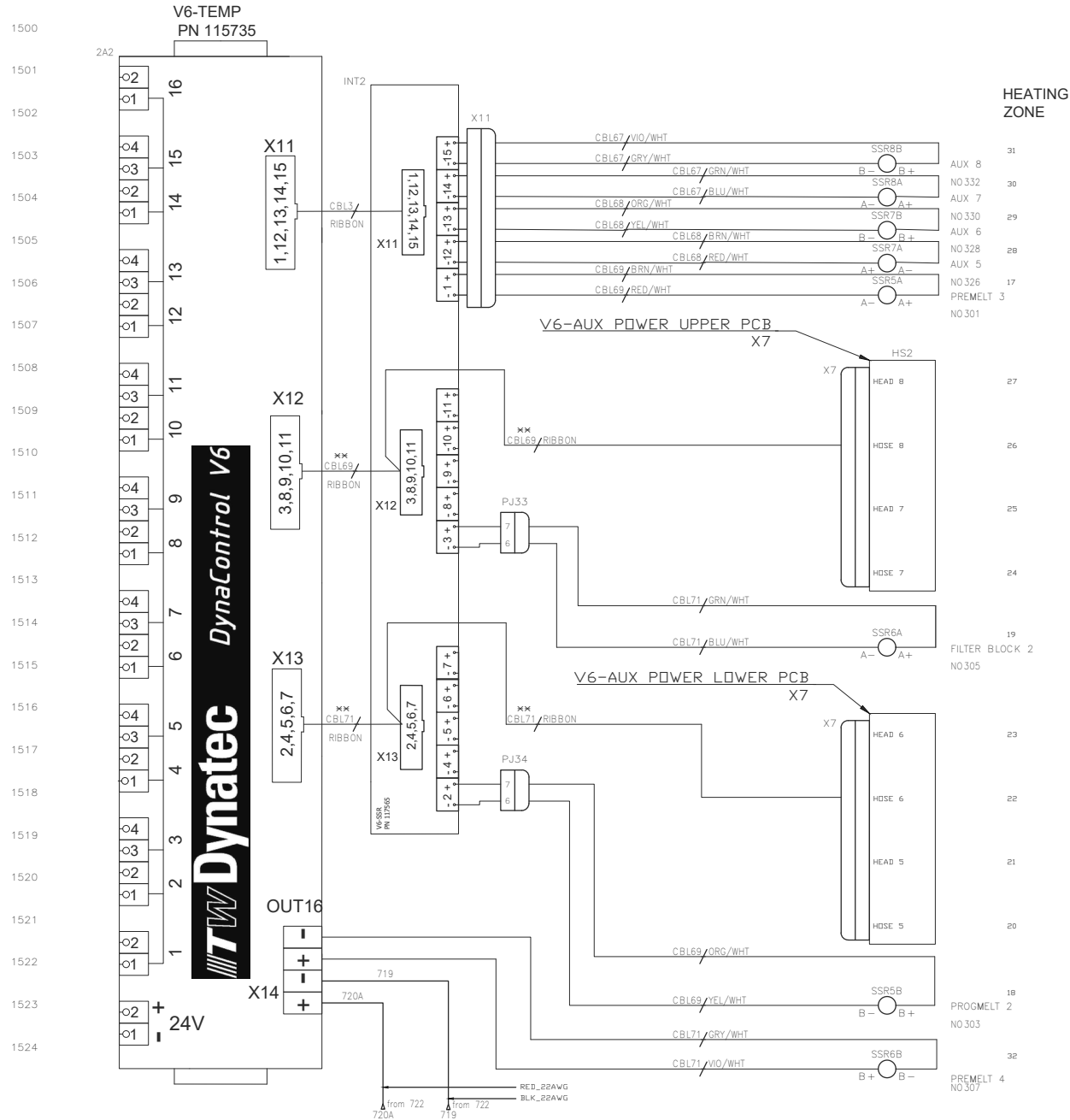

****NOTE**

CONFIGURATION SHOWN IS FOR IS FOR A SYSTEM WITH EIGHT OR MORE HOSE/HEAD CONNECTIONS REQUIRED WHERE CBL69 AND CBL71 ARE DUAL CABLES (P/N 823321). FOR A SYSTEM WITH LESS THAN EIGHT HOSE/HEAD CONNECTIONS, A SINGLE CABLE (P/N 823319) IS CONNECTED BETWEEN CONNECTOR X12/X13 ON V6-TEMP AND X12/X13 ON INT2 WHERE A PCB HOSE/HEAD CONNECTION IS NOT REQUIRED.

ITEM	PART NUMBER	QTY	UOM	DESCRIPTION

DO NOT SCALE DRAWING		TOLERANCES (UNLESS OTHERWISE SPECIFIED)		ITW Dynatec	
COMPUTER DESCRIPTIONS (CHARACTERS)		NEXT ASSY		TITLE: V6, M210, 240V, DH	
FOR MACHINING STANDARDS AND DIMENSIONS, SEE ITW/DYNATEC SPEC. ADDRESS		SOURCE: T		SSR OUTPUTS	
DATE: 10.07.13		SHEET: 15 OF SHEETS		DRAWN BY: BFO	
				CHECKED BY: ---	
				APPROVED BY: ---	
				DRAWING NO: 821067	

THIS DRAWING IS THE PROPERTY OF ITW/DYNATEC.
DO NOT REPRODUCE OR DISCLOSE TO
OTHERS WITHOUT EXPRESS WRITTEN
CONSENT OF ITW/DYNATEC.

REVISIONS					
REV.	BY	DESCRIPTION	DATE	BY	APPROVED

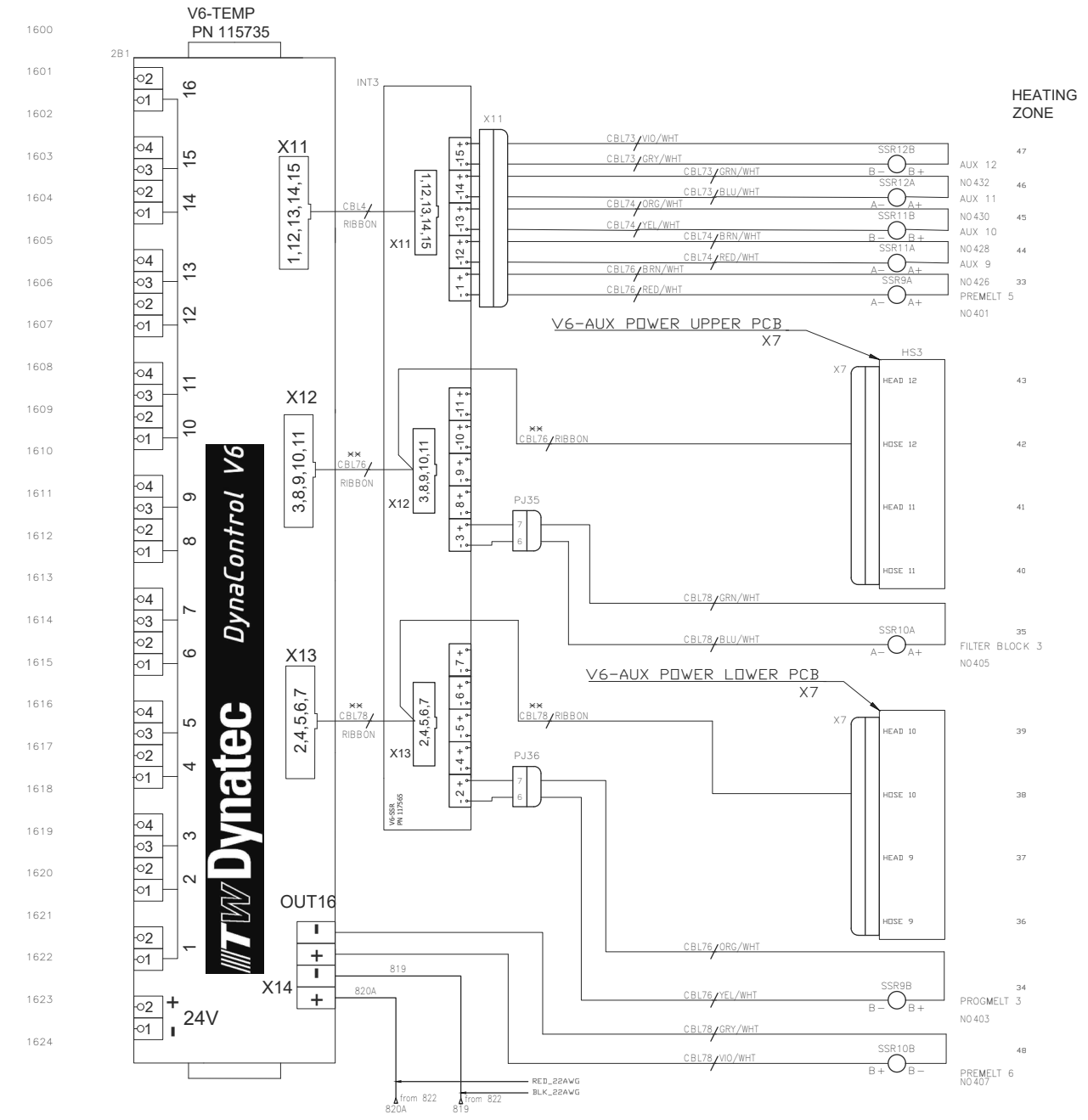

****NOTE**

CONFIGURATION SHOWN IS FOR IS FOR A SYSTEM WITH TWELVE HOSE/HEAD CONNECTIONS REQUIRED WHERE CBL76 AND CBL78 ARE DUAL CABLES (P/N 823321). FOR A SYSTEM WITH LESS THAN TWELVE HOSE/HEAD CONNECTIONS, A SINGLE CABLE (P/N 823319) IS CONNECTED BETWEEN CONNECTOR X12/X13 ON V6-TEMP AND X12/X13 ON INT3 WHERE A PCB HOSE/HEAD CONNECTION IS NOT REQUIRED.

ITEM	PART NUMBER	QTY	UOM	DESCRIPTION

DO NOT SCALE DRAWING		TOLERANCES (UNLESS OTHERWISE SPECIFIED)		ITW Dynatec	
COMPUTER DESCRIPTIONS (CHARACTERS)		NEXT ASSY		TITLE: V6_M210_240V_DH	
FOR MACHINING STANDARDS AND DIMENSIONS, SEE ITW/DYNATEC SPEC. APPEND		SOURCE: T		SSR OUTPUTS	
DATE: 10.07.13		SHEET: 16 OF SHEETS		DRAWING NO: 821067	

THIS DRAWING IS THE PROPERTY OF INVA/DYNATEC.
DO NOT REPRODUCE OR DISCLOSE TO
OTHERS WITHOUT EXPRESS WRITTEN
CONSENT OF INVA/DYNATEC.

REVISIONS				
REV.	BY	DESCRIPTION	DATE	APPROVED

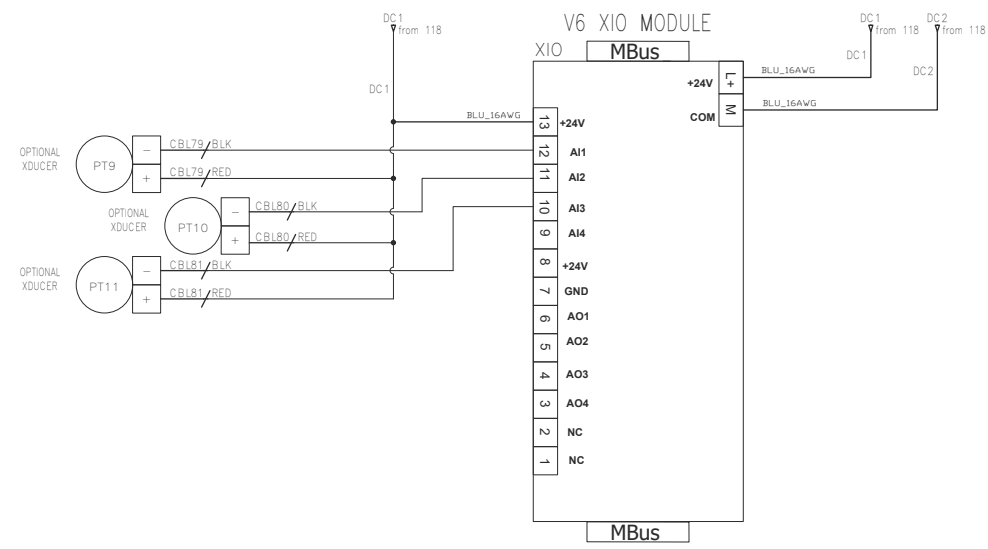
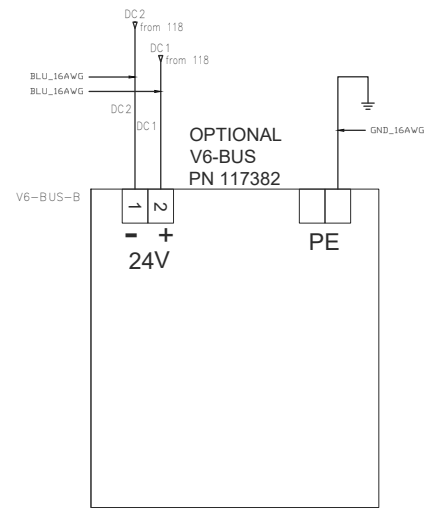
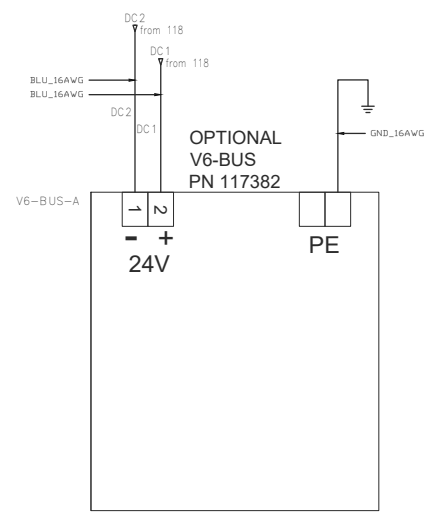

ITEM	PART NUMBER	QTY	UOM	DESCRIPTION												
PARTS LIST																
DO NOT SCALE DRAWING				<table border="1"> <tr> <td>TOLERANCES (UNLESS OTHERWISE SPECIFIED)</td> <td>INCHES</td> <td>MILLIMETERS</td> </tr> <tr> <td> </td> <td> </td> <td> </td> </tr> </table>	TOLERANCES (UNLESS OTHERWISE SPECIFIED)	INCHES	MILLIMETERS									
TOLERANCES (UNLESS OTHERWISE SPECIFIED)	INCHES	MILLIMETERS														
COMPUTER DESCRIPTIONS (CHARACTERS)				<table border="1"> <tr> <td>STATUS</td> <td>DES</td> <td>SCALE</td> <td>DRAWN BY</td> <td>CHECKED BY</td> <td>APP'D BY</td> </tr> <tr> <td> </td> <td> </td> <td> </td> <td> </td> <td> </td> <td> </td> </tr> </table>	STATUS	DES	SCALE	DRAWN BY	CHECKED BY	APP'D BY						
STATUS	DES	SCALE	DRAWN BY	CHECKED BY	APP'D BY											
FOR MACHINING STANDARDS AND DIMENSIONS, SEE INV/DYNATEC SPEC. ADDRESS				<table border="1"> <tr> <td>DATE</td> <td>SHEET</td> <td>OF SHEETS</td> <td>DRAWING NO.</td> </tr> <tr> <td>10.07.13</td> <td>17</td> <td>18</td> <td>821067</td> </tr> </table>	DATE	SHEET	OF SHEETS	DRAWING NO.	10.07.13	17	18	821067				
DATE	SHEET	OF SHEETS	DRAWING NO.													
10.07.13	17	18	821067													



TITLE: V6, M210, 240V, DH
OPTIONS

11.8 Schematics M210 V6 400V Single Hopper, PN 820948T

THIS DRAWING IS THE PROPERTY OF INV/DYNATEC.
DO NOT REPRODUCE OR DISCLOSE TO
OTHERS WITHOUT EXPRESS WRITTEN
CONSENT OF INV/DYNATEC.

REVISIONS					
REV.	BY	DESCRIPTION	DATE	BY	APPROVED
17050	L	CONVERTED TO ACADE	07.31.17	BFG	
CCN702	M	CORRECTIONS PER ASSEMBLY	09.22.17	BFG	
CCN799	N	CORRECT WIRE NUMBERS PG.3	01.09.18	BFG	
18146	P	ADDED DRIVE DISCONNECT	11.26.18	BFG	
ECNS76	D	ADD GND WIRE TO XF1 SECONDARY	09.27.19	DJT	
ECN82	R	REVISE SSR CABLE DETAIL (SHT 13/14/15)	02.24.20	DJT	
ECN849	S	CORRECT DV3 WIRING (SHT 9)	03.11.20	DJT	
ECN1309	T	REVISE FLT1	05.17.21	JJB	

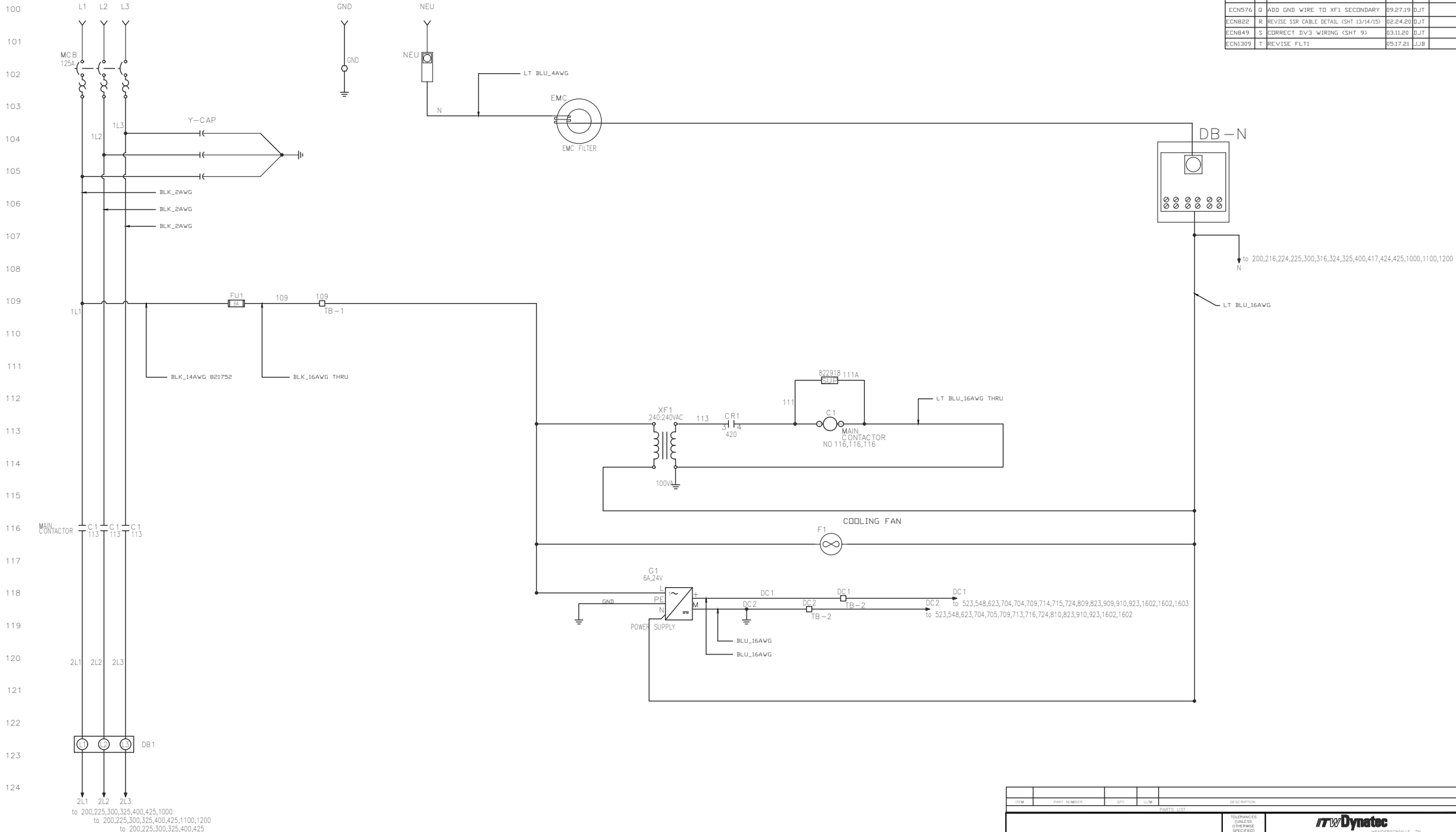

to 200,225,300,325,400,425,1000
to 200,225,300,325,400,425,1100,1200
to 200,225,300,325,400,425

ITEM	PART NUMBER	QTY	U/M	DESCRIPTION
PARTS LIST				
TOLERANCES (UNLESS OTHERWISE SPECIFIED)				
DO NOT SCALE DRAWING				
COMPUTER DESCRIPTIONS (CHARACTERS)				
NEXT ASSY				
FOR MACHINING STANDARDS AND DIMENSIONS, SEE INV/DYNATEC SPEC. APPEND				
SOURCE		REV.		DATE
T		T		08.08.13
TITLE: V6, M210 400V SH POWER DISTRIBUTION		SCALE: BFG		CHECKED BY: --
DRAWN BY: BFG		APPROVED BY: --		
SHEET 1		OF SHEETS 17		DRAWING NO. 820948

THIS DRAWING IS THE PROPERTY OF IN/DMATEC.
DO NOT REPRODUCE OR DISCLOSE TO
OTHERS WITHOUT EXPRESS WRITTEN
CONSENT OF IN/DMATEC.

REVISIONS				
REV.	BY	DESCRIPTION	DATE	APPROVED

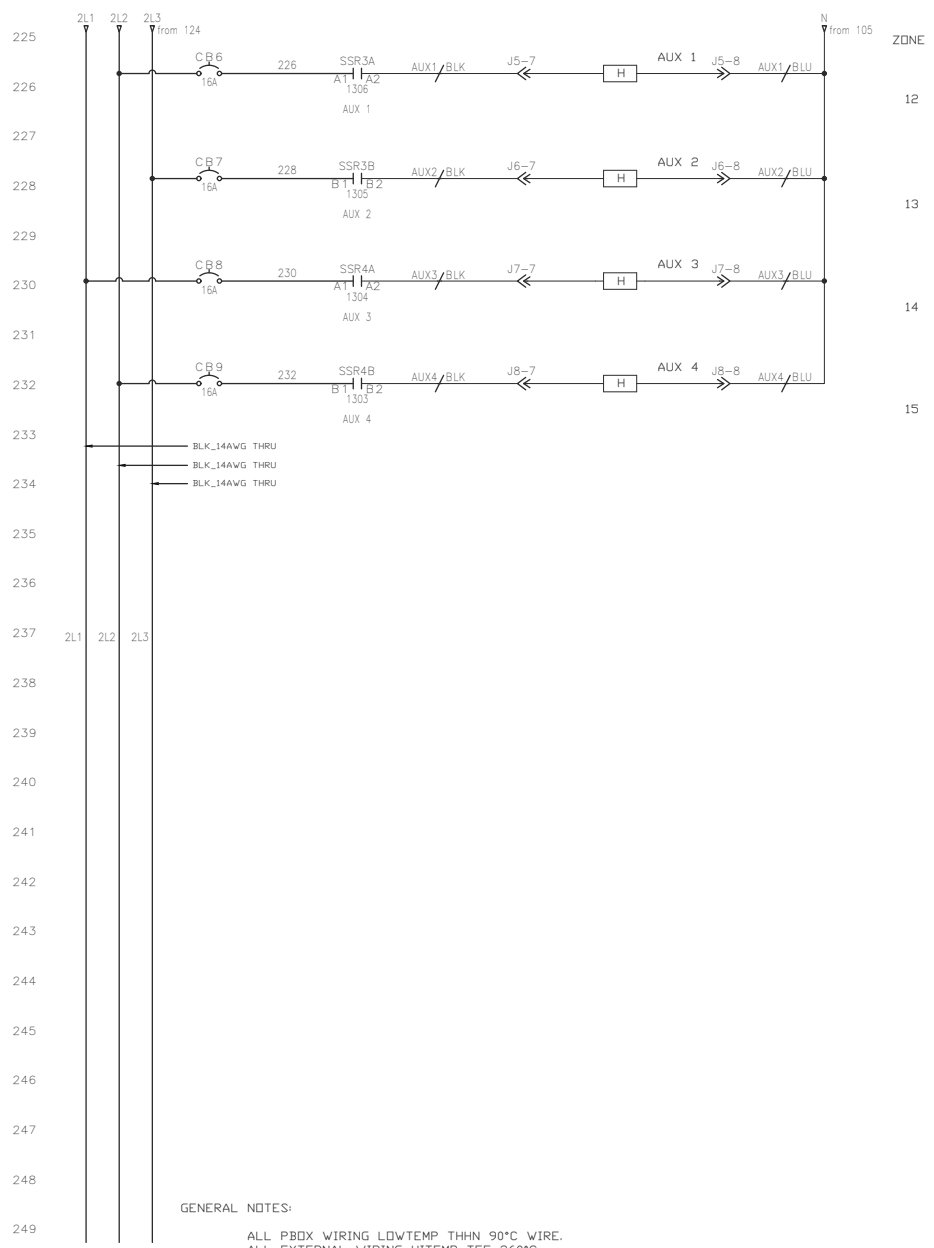
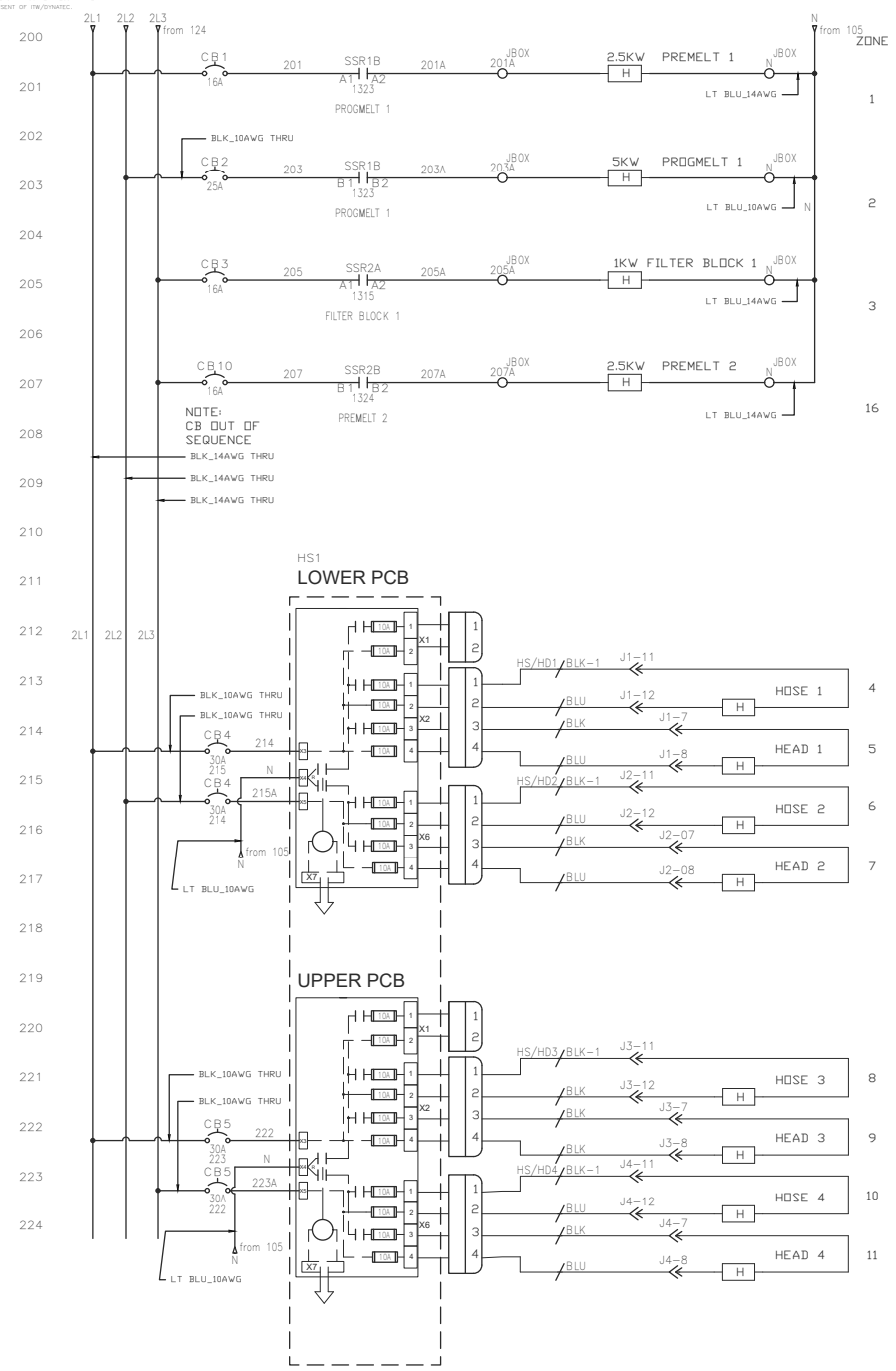

GENERAL NOTES:

- ALL PBOX WIRING LOWTEMP THHN 90°C WIRE.
- ALL EXTERNAL WIRING HITEMP TFE 260°C OR EQUIV.
- DENOTES TERMINAL IN PBOX
- DENOTES TERMINAL IN JBOX
- APPLY WIRE NUMBERS TO BOTH ENDS OF WIRE.
- DENOTES DEVICES EXTERNAL TO PBOX.
- WIRE ALL GROUND CONNECTIONS PER DRAWING 804704.
- THIS IS A GENERAL SCHEMATIC. NOT ALL DEVICES MAY BE PRESENT. SEE ORDER FOR NUMBER OF HOSES, HEADS, AUX, AND MOTORS.

ITEM	PART NUMBER	QTY	UOM	DESCRIPTION
PARTS LIST				
TOLERANCES (UNLESS OTHERWISE SPECIFIED)				
DO NOT SCALE DRAWING		STATUS		DESIGN
COMPUTER DESCRIPTIONS (CHARACTERS)		NEXT ASSY		SCALE: DRAWN BY: CHECKED BY: APP'D BY:
FOR MACHINING STANDARDS AND DIMENSIONS, SEE IN/DMATEC SPEC. A05030		SOURCE		DATE: 08.08.13 SHEET 2 OF SHEETS 17 DRAWING NO. 820948



TITLE: V6, M210 400V SH HEATER CIRCUITS

THIS DRAWING IS THE PROPERTY OF INVDYNATEC.
DO NOT REPRODUCE OR DISCLOSE TO
OTHERS WITHOUT EXPRESS WRITTEN
CONSENT OF INVDYNATEC.

REVISIONS				
REV.	BY	DESCRIPTION	DATE	APPROVED

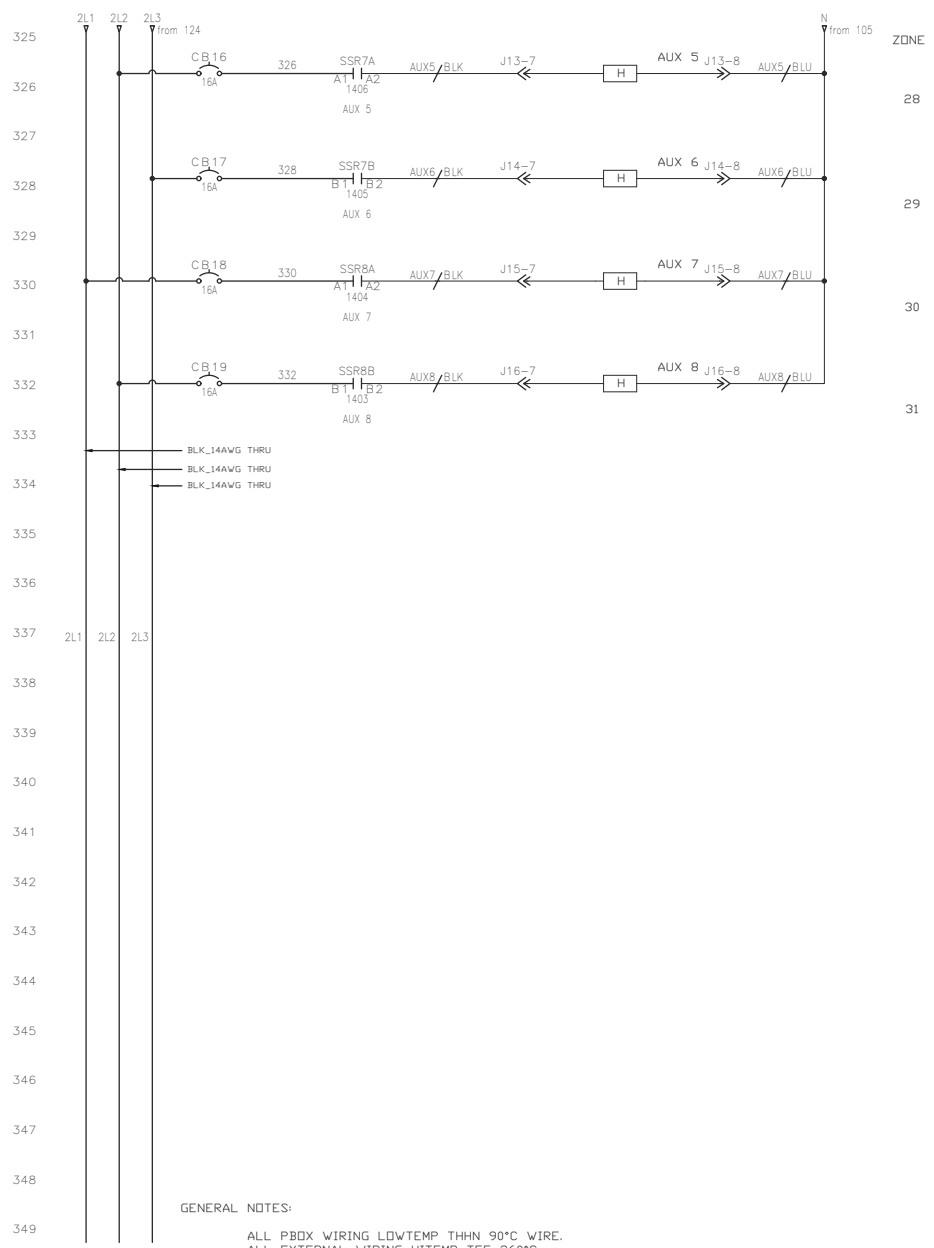
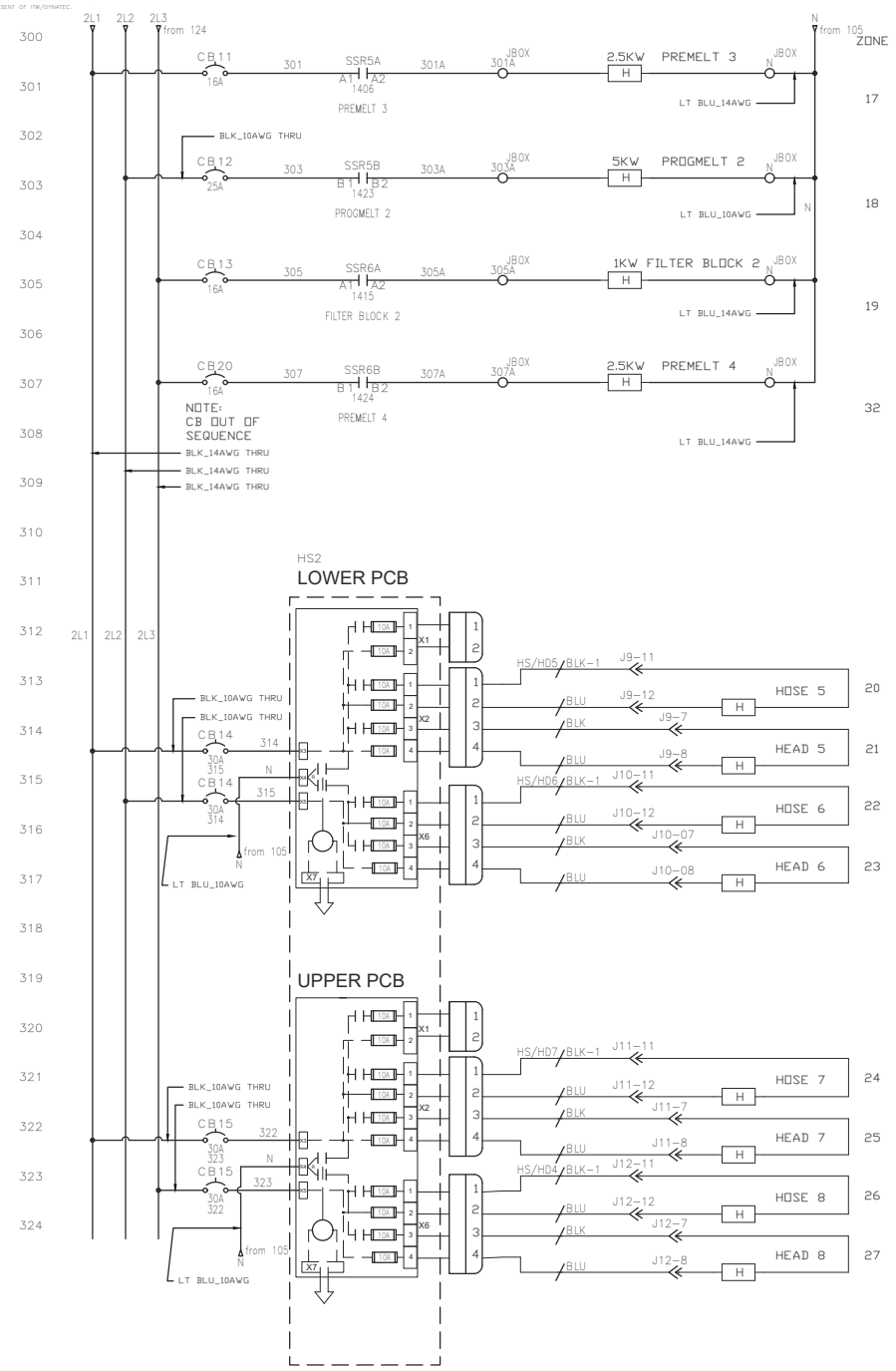

GENERAL NOTES:

- ALL PBOX WIRING LOWTEMP THHN 90°C WIRE.
- ALL EXTERNAL WIRING HITEMP TFE 260°C OR EQUIV.
- DENOTES TERMINAL IN PBOX
- DENOTES TERMINAL IN JBOX
- APPLY WIRE NUMBERS TO BOTH ENDS OF WIRE.
- DENOTES DEVICES EXTERNAL TO PBOX.
- WIRE ALL GROUND CONNECTIONS PER DRAWING 804704.
- THIS IS A GENERAL SCHEMATIC. NOT ALL DEVICES MAY BE PRESENT. SEE ORDER FOR NUMBER OF HOSES, HEADS, AUX, AND MOTORS.

ITEM	PART NUMBER	QTY	UOM	DESCRIPTION
PARTS LIST				
TOLERANCES (UNLESS OTHERWISE SPECIFIED)				
DO NOT SCALE DRAWING		STATUS		DESIGN
NEXT ASSY		SCALE:		DATE:
FOR MACHINING STANDARDS AND DIMENSIONS, SEE INVDYNATEC SPEC. A03539		SOURCE		REV.:
COMPUTER DESCRIPTIONS (CHARACTERS)		DATE:		08.08.13
SHEET		OF SHEETS		17
DRAWN BY:		CHECKED BY:		APP'D BY:
BFG		---		---
DRAWING NO.		820948		



TITLE: V6, M210 400V SH HEATER CIRCUITS

THIS DRAWING IS THE PROPERTY OF INVA/DYNATEC.
DO NOT REPRODUCE OR DISCLOSE TO
OTHERS WITHOUT EXPRESS WRITTEN
CONSENT OF INVA/DYNATEC.

REVISIONS				
REV.	BY	DESCRIPTION	DATE	APPROVED

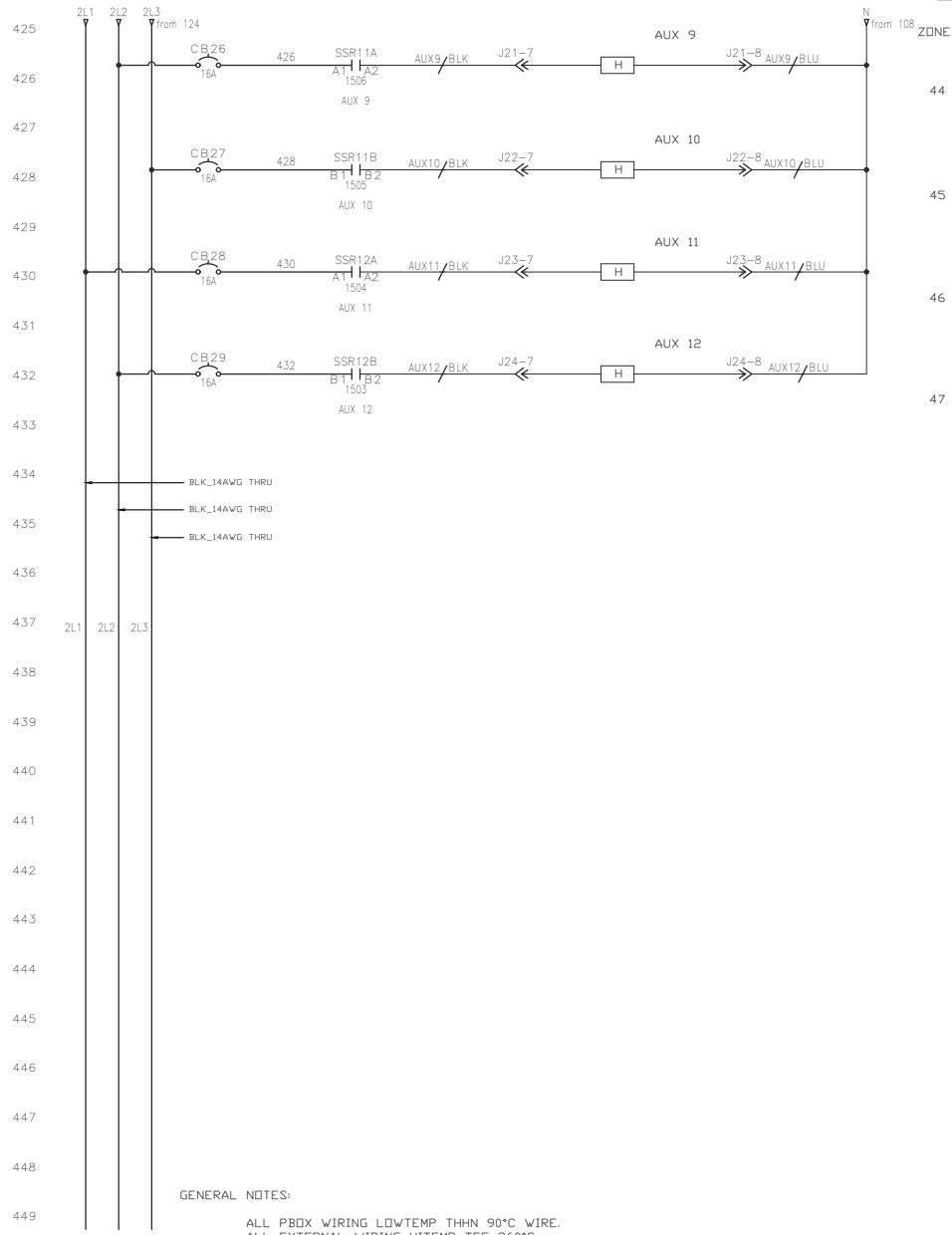
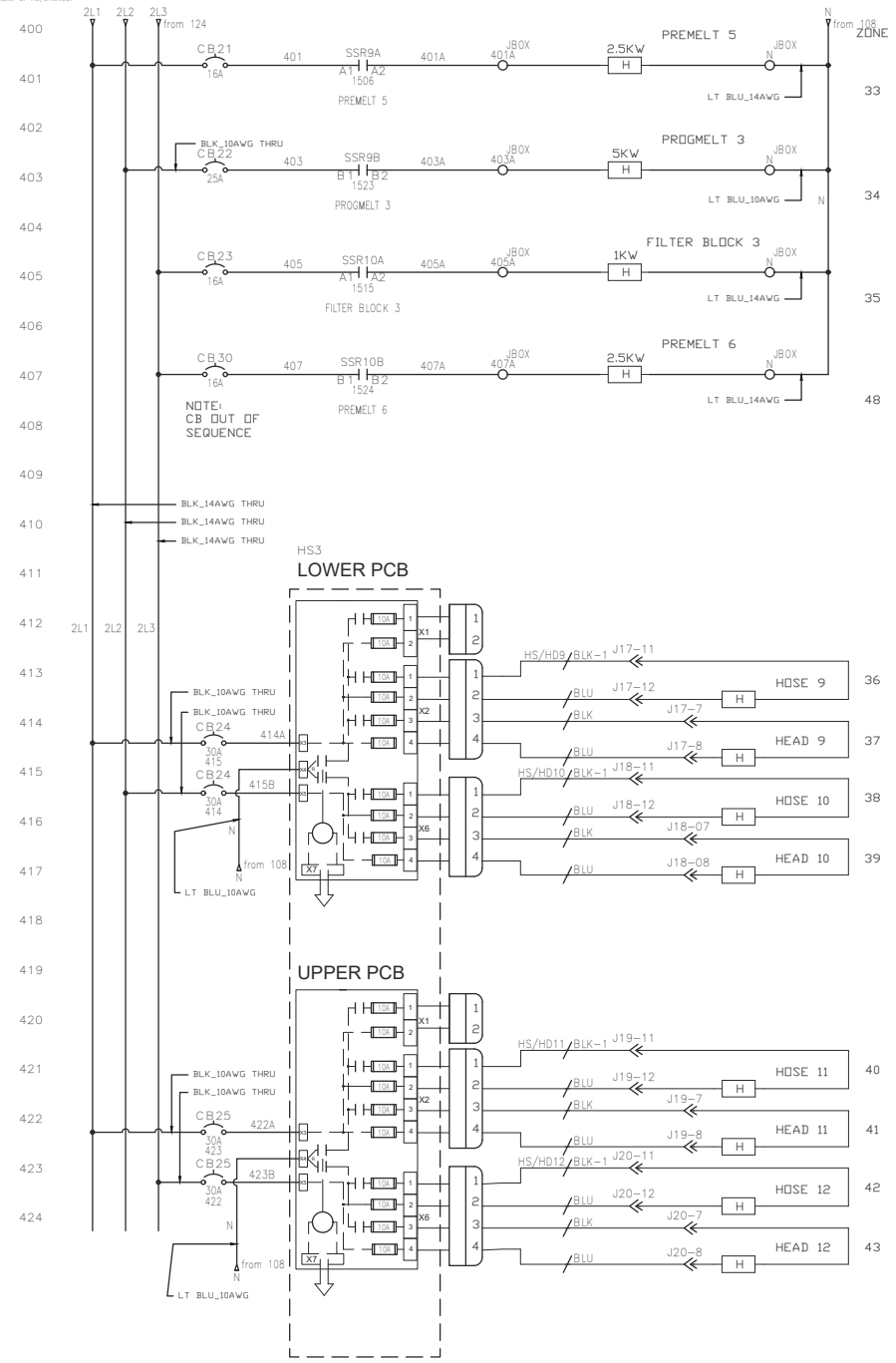

GENERAL NOTES:

- DENOTES TERMINAL IN PBOX
- DENOTES TERMINAL IN JBOX
- APPLY WIRE NUMBERS TO BOTH ENDS OF WIRE.
- DENOTES DEVICES EXTERNAL TO PBOX.
- WIRE ALL GROUND CONNECTIONS PER DRAWING 804704.
- THIS IS A GENERAL SCHEMATIC. NOT ALL DEVICES MAY BE PRESENT. SEE ORDER FOR NUMBER OF HOSES, HEADS, AUX, AND MOTORS.

ITEM	PART NUMBER	QTY	UOM	DESCRIPTION
PARTS LIST				
TOLERANCES (UNLESS OTHERWISE SPECIFIED)				
DO NOT SCALE DRAWING		STATUS		DESIGN
COMPUTER DESCRIPTIONS (CHARACTERS)		NEXT ASSY		SCALE:
FOR MACHINING STANDARDS AND DIMENSIONS, SEE INVA/DYNATEC SPEC. A03539		SOURCE		DATE:
		REV. T		08.08.13
		SHEET 4		OF SHEETS 17
		DRAWN BY: BFG		CHECKED BY: --
		APPROVED BY: --		DRAWING NO: 820948



TITLE: V6, M210 400V SH HEATER CIRCUITS

INVA/DYNATEC, INC. HOUSTON, TEXAS

REVISIONS					
REV.	BY	DESCRIPTION	DATE	BY	APPROVED

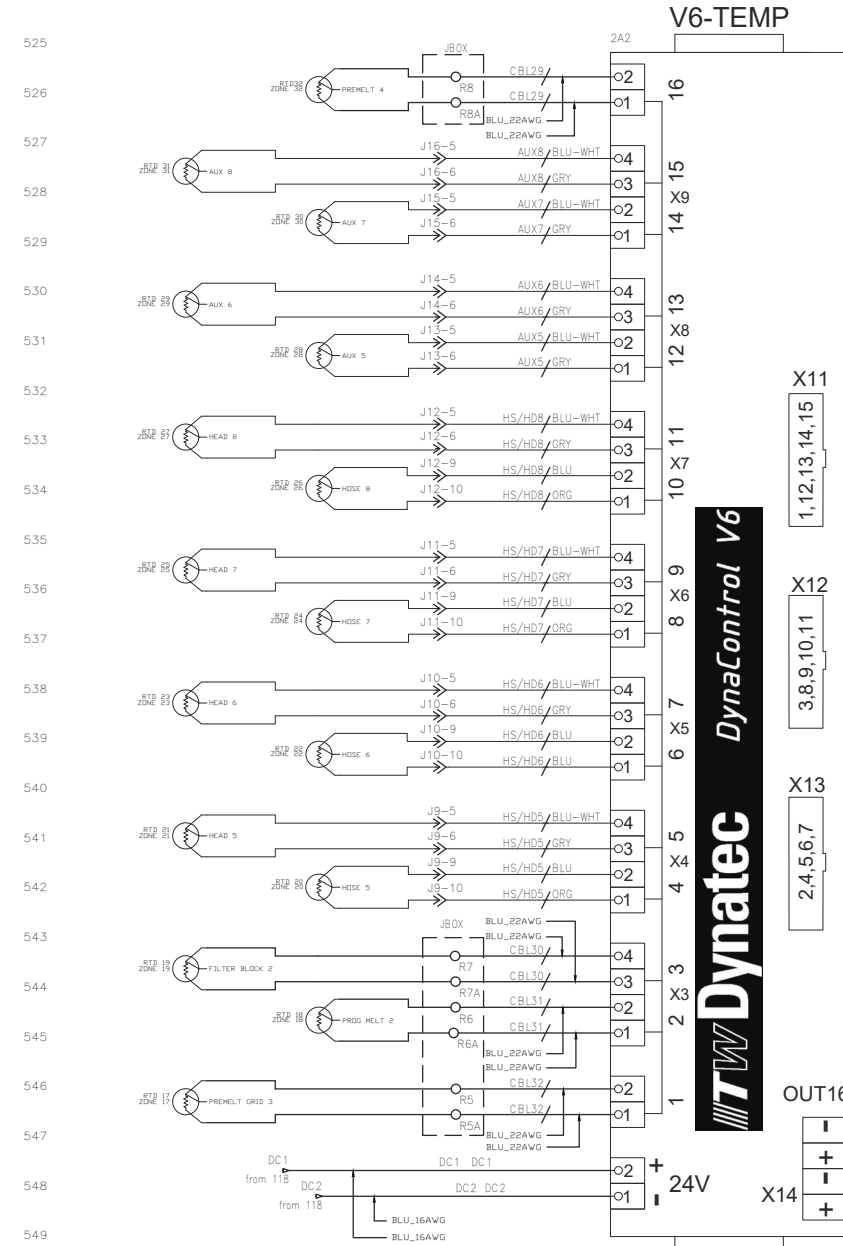
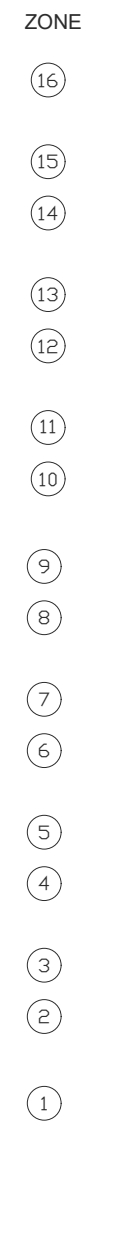
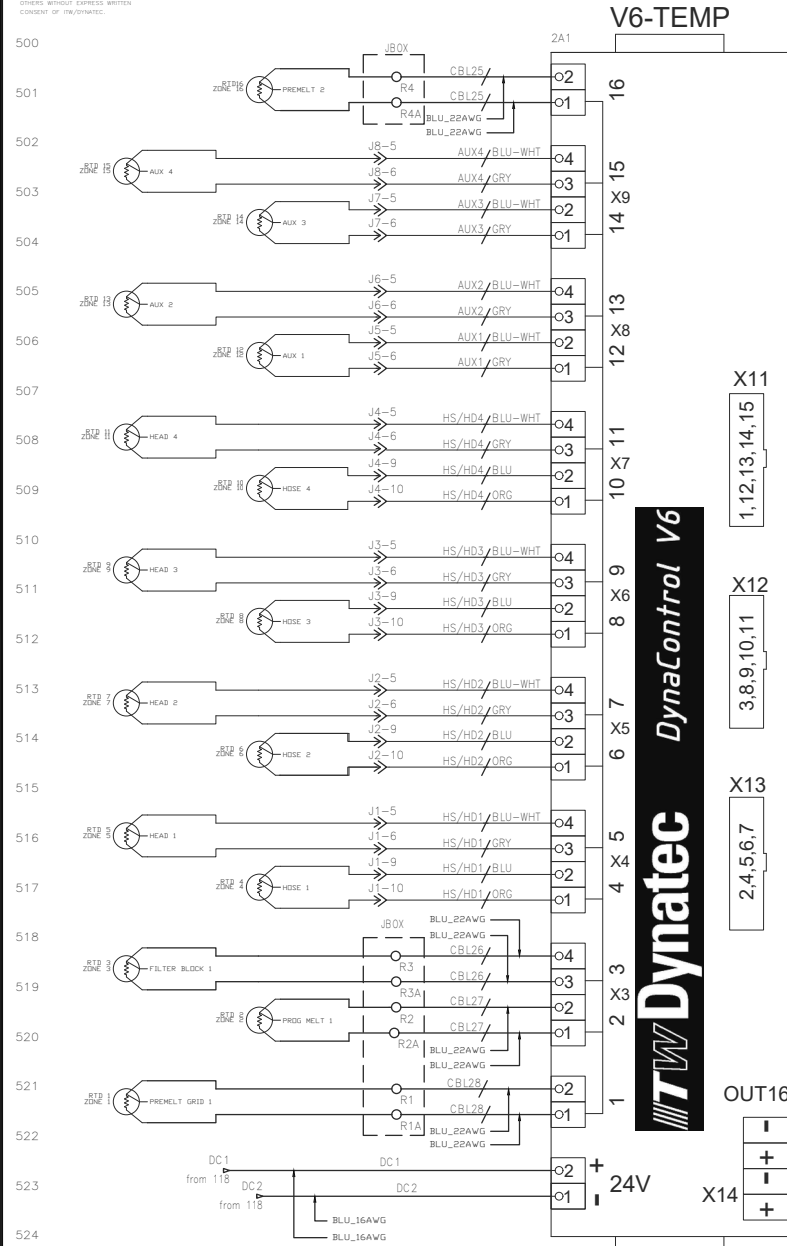

ITEM	PART NUMBER	QTY	UOM	DESCRIPTION
PARTS LIST				

DO NOT SCALE DRAWING		NEXT ASSY	
FOR MACHINING STANDARDS AND DIMENSIONS, SEE INVDYNATEC SPEC. A0509		STATUS	REV
		T	
DATE	SHEET	OF SHEETS	DRAWING NO.
08.08.13	5	17	820948

INVDYNATEC
INDUSTRIAL PROFESSIONAL THERMAL INSTRUMENTATION

TITLE: V6_M210 400V SH
RTD INPUTS

DRAWN BY: B F Q
CHECKED BY: --
APPROVED BY: --

REVISIONS					
REV.	BY	DESCRIPTION	DATE	BY	APPROVED

THIS DRAWING IS THE PROPERTY OF INVA/DYNATEC.
DO NOT REPRODUCE OR DISCLOSE TO
OTHERS WITHOUT EXPRESS WRITTEN
CONSENT OF INVA/DYNATEC.

700
701
702
703
704
705
706
707
708
709
710
711
712
713
714
715
716
717
718
719
720
721
722
723
724

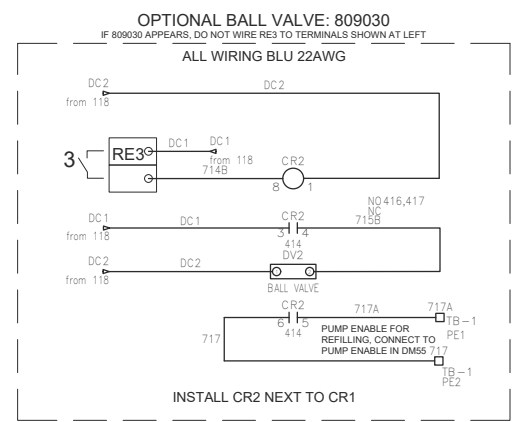
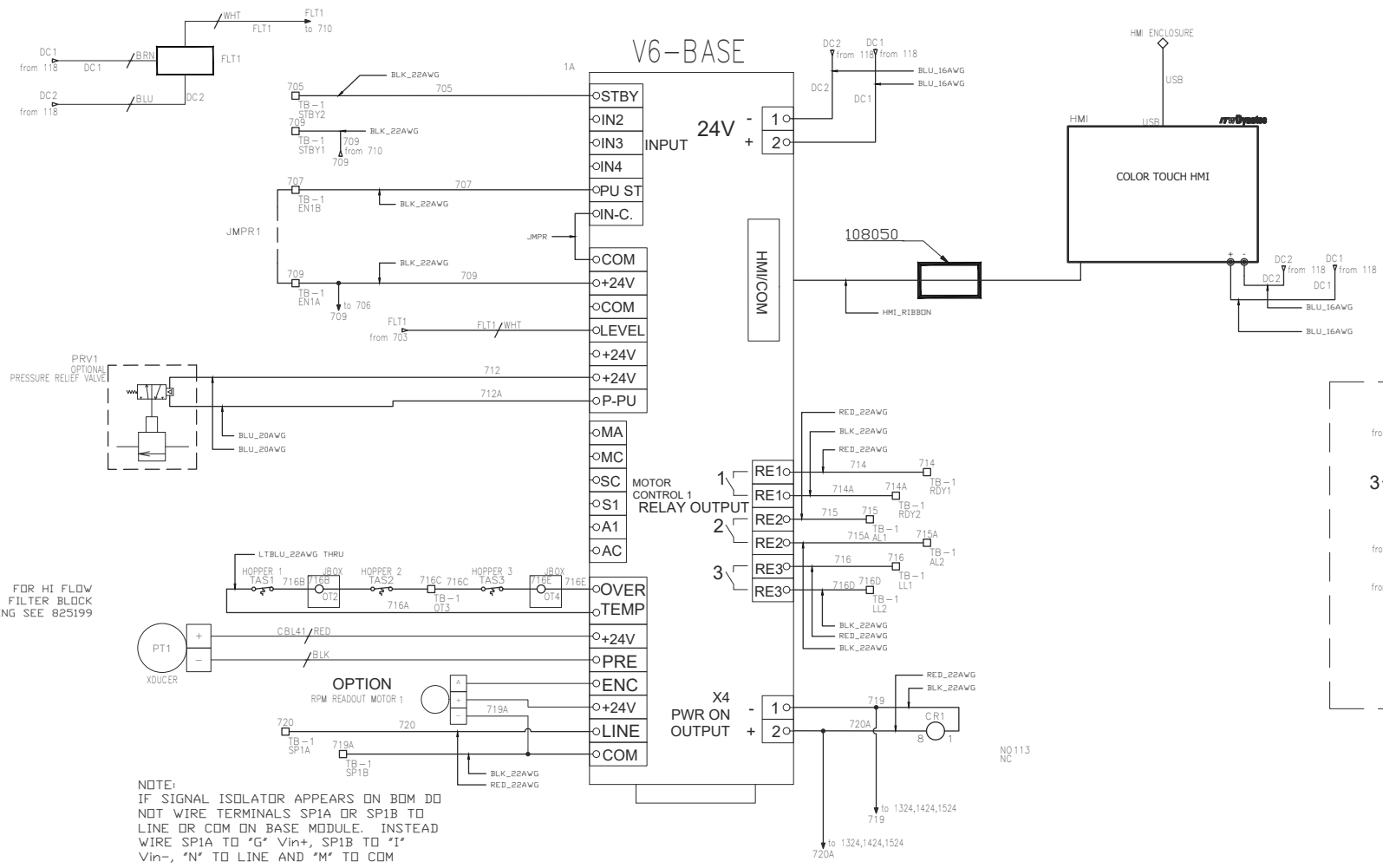

NOTE:
IF SIGNAL ISOLATOR APPEARS ON BOM DO
NOT WIRE TERMINALS SP1A OR SP1B TO
LINE OR COM ON BASE MODULE. INSTEAD
WIRE SP1A TO 'G' Vin+, SP1B TO 'I'
Vin-, 'N' TO LINE AND 'M' TO COM

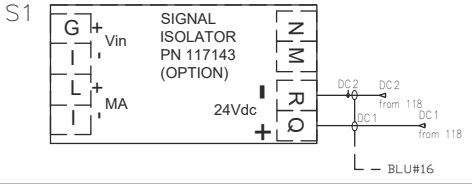

ITEM	PART NUMBER	QTY	UOM	DESCRIPTION																														
PARTS LIST																																		
<table border="1"> <tr> <td colspan="2">DO NOT SCALE DRAWING</td> <td colspan="2">TOLERANCES (UNLESS OTHERWISE SPECIFIED)</td> <td colspan="2"> </td> </tr> <tr> <td colspan="2">TITLE: V6_M210 400V SH</td> <td colspan="2">STATUS: DES</td> <td colspan="2">DRAWN BY: B FQ</td> </tr> <tr> <td colspan="2">SCALE:</td> <td colspan="2">DATE: 08.08.13</td> <td colspan="2">CHECKED BY: --</td> </tr> <tr> <td colspan="2">FOR MACHINING STANDARDS AND DIMENSIONS, SEE INVA/DYNATEC SPEC. APPENDIX</td> <td colspan="2">SHEET 7</td> <td colspan="2">OF SHEETS 17</td> </tr> <tr> <td colspan="2"></td> <td colspan="2">DRAWING NO. 820948</td> <td colspan="2"></td> </tr> </table>					DO NOT SCALE DRAWING		TOLERANCES (UNLESS OTHERWISE SPECIFIED)				TITLE: V6_M210 400V SH		STATUS: DES		DRAWN BY: B FQ		SCALE:		DATE: 08.08.13		CHECKED BY: --		FOR MACHINING STANDARDS AND DIMENSIONS, SEE INVA/DYNATEC SPEC. APPENDIX		SHEET 7		OF SHEETS 17				DRAWING NO. 820948			
DO NOT SCALE DRAWING		TOLERANCES (UNLESS OTHERWISE SPECIFIED)																																
TITLE: V6_M210 400V SH		STATUS: DES		DRAWN BY: B FQ																														
SCALE:		DATE: 08.08.13		CHECKED BY: --																														
FOR MACHINING STANDARDS AND DIMENSIONS, SEE INVA/DYNATEC SPEC. APPENDIX		SHEET 7		OF SHEETS 17																														
		DRAWING NO. 820948																																

REVISIONS					
REV.	BY	DESCRIPTION	DATE	BY	APPROVED

THIS DRAWING IS THE PROPERTY OF INVA/DYNATEC.
DO NOT REPRODUCE OR DISCLOSE TO
OTHERS WITHOUT EXPRESS WRITTEN
CONSENT OF INVA/DYNATEC.

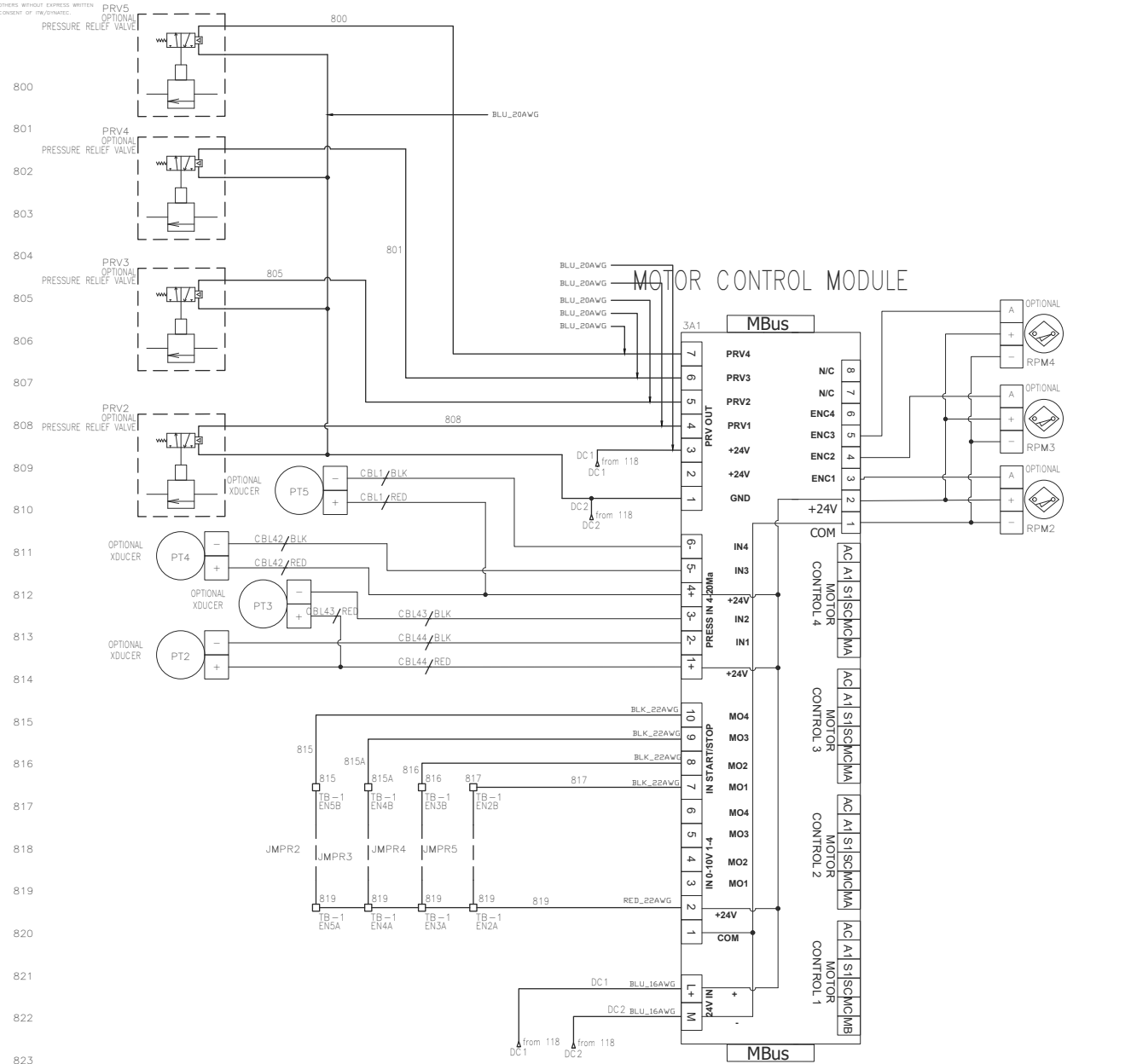

ITEM	PART NUMBER	QTY	UOM	DESCRIPTION																																				
PARTS LIST																																								
<table border="1"> <tr> <td colspan="2">DO NOT SCALE DRAWING</td> <td colspan="2">TOLERANCES (UNLESS OTHERWISE SPECIFIED)</td> <td colspan="2"> </td> </tr> <tr> <td colspan="2">COMPUTER DESCRIPTIONS (CHARACTERS)</td> <td colspan="2">NEXT ASSY</td> <td colspan="2">TITLE: V6, M210 400V SH</td> </tr> <tr> <td colspan="2">FOR MACHINING STANDARDS AND DIMENSIONS, SEE INVA/DYNATEC SPEC. APPEND</td> <td colspan="2">SOURCE: T</td> <td colspan="2">PRESSURE INPUTS</td> </tr> <tr> <td colspan="2">DATE: 08.08.13</td> <td colspan="2">SCALE: B FQ</td> <td colspan="2">DRAWN BY: B FQ</td> </tr> <tr> <td colspan="2">SHEET: 8</td> <td colspan="2">OF SHEETS: 17</td> <td colspan="2">CHECKED BY: --</td> </tr> <tr> <td colspan="2">DRAWING NO: 820948</td> <td colspan="2">APPROVED BY: --</td> <td colspan="2">DATE: 08.08.13</td> </tr> </table>					DO NOT SCALE DRAWING		TOLERANCES (UNLESS OTHERWISE SPECIFIED)				COMPUTER DESCRIPTIONS (CHARACTERS)		NEXT ASSY		TITLE: V6, M210 400V SH		FOR MACHINING STANDARDS AND DIMENSIONS, SEE INVA/DYNATEC SPEC. APPEND		SOURCE: T		PRESSURE INPUTS		DATE: 08.08.13		SCALE: B FQ		DRAWN BY: B FQ		SHEET: 8		OF SHEETS: 17		CHECKED BY: --		DRAWING NO: 820948		APPROVED BY: --		DATE: 08.08.13	
DO NOT SCALE DRAWING		TOLERANCES (UNLESS OTHERWISE SPECIFIED)																																						
COMPUTER DESCRIPTIONS (CHARACTERS)		NEXT ASSY		TITLE: V6, M210 400V SH																																				
FOR MACHINING STANDARDS AND DIMENSIONS, SEE INVA/DYNATEC SPEC. APPEND		SOURCE: T		PRESSURE INPUTS																																				
DATE: 08.08.13		SCALE: B FQ		DRAWN BY: B FQ																																				
SHEET: 8		OF SHEETS: 17		CHECKED BY: --																																				
DRAWING NO: 820948		APPROVED BY: --		DATE: 08.08.13																																				

THIS DRAWING IS THE PROPERTY OF ITR/DYNATEC.
DO NOT REPRODUCE OR DISCLOSE TO
OTHERS WITHOUT EXPRESS WRITTEN
CONSENT OF ITR/DYNATEC.

REVISIONS					
REV.	BY	DESCRIPTION	DATE	BY	APPROVED

900
901
902
903
904
905
906
907
908
909
910
911
912
913
914
915
916
917
918
919
920
921
922
923
924

MOTOR CONTROL MODULE

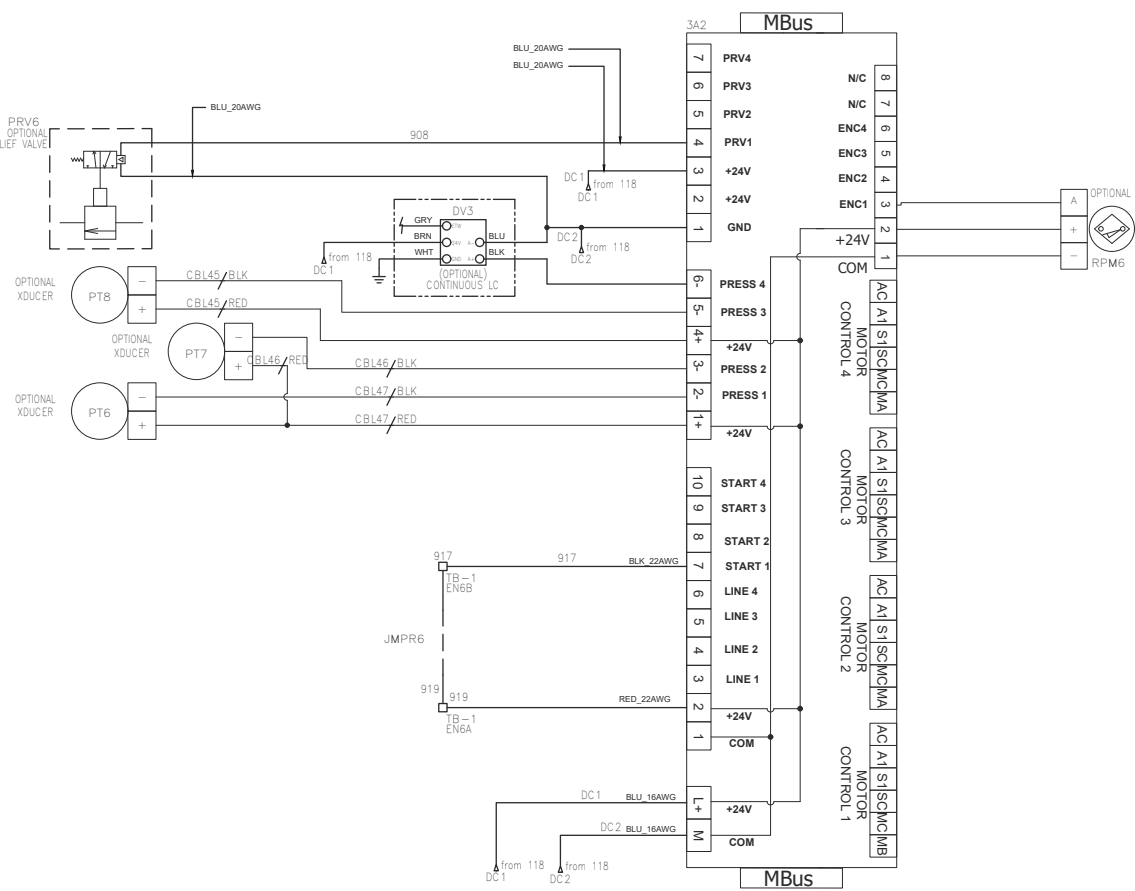

GENERAL NOTES:

- ALL PBOX WIRING LOWTEMP THHN 90°C WIRE.
- ALL EXTERNAL WIRING HITEMP TFE 260°C OR EQUIV.
- DENOTES TERMINAL IN PBOX
- DENOTES TERMINAL IN JBOX
- APPLY WIRE NUMBERS TO BOTH ENDS OF WIRE.
- DENOTES DEVICES EXTERNAL TO PBOX.
- DENOTES WIRING TO BE DONE BY OTHER/NOT INCLUDED.
- WIRE ALL GROUND CONNECTIONS PER DRAWING 804704
- THIS IS A GENERAL SCHEMATIC. NOT ALL DEVICES MAY BE PRESENT. SEE ORDER FOR NUMBER OF HOSES, HEADS, AUX. AND MOTORS.

ITEM	PART NUMBER	QTY	U/M	DESCRIPTION	TOLERANCES (UNLESS OTHERWISE SPECIFIED)	STATUS	REV	DATE	BY	APPROVED
PARTS LIST										
DO NOT SCALE DRAWING					TITLE: V6, M210 400V SH PRESSURE INPUTS		SCALE: B/FQ		DRAWN BY: B/FQ	
FOR MACHINING STANDARDS AND DIMENSIONS, SEE ITR/DYNATEC SPEC. APPROV					DATE: 08.08.13		SHEET: 9		OF SHEETS: 17	
					DRAWING NO: 820948					

REVISIONS					
REV.	BY	DESCRIPTION	DATE	BY	APPROVED

THIS DRAWING IS THE PROPERTY OF ITW/DYNATEC.
DO NOT REPRODUCE OR DISCLOSE TO
OTHERS WITHOUT EXPRESS WRITTEN
CONSENT OF ITW/DYNATEC.

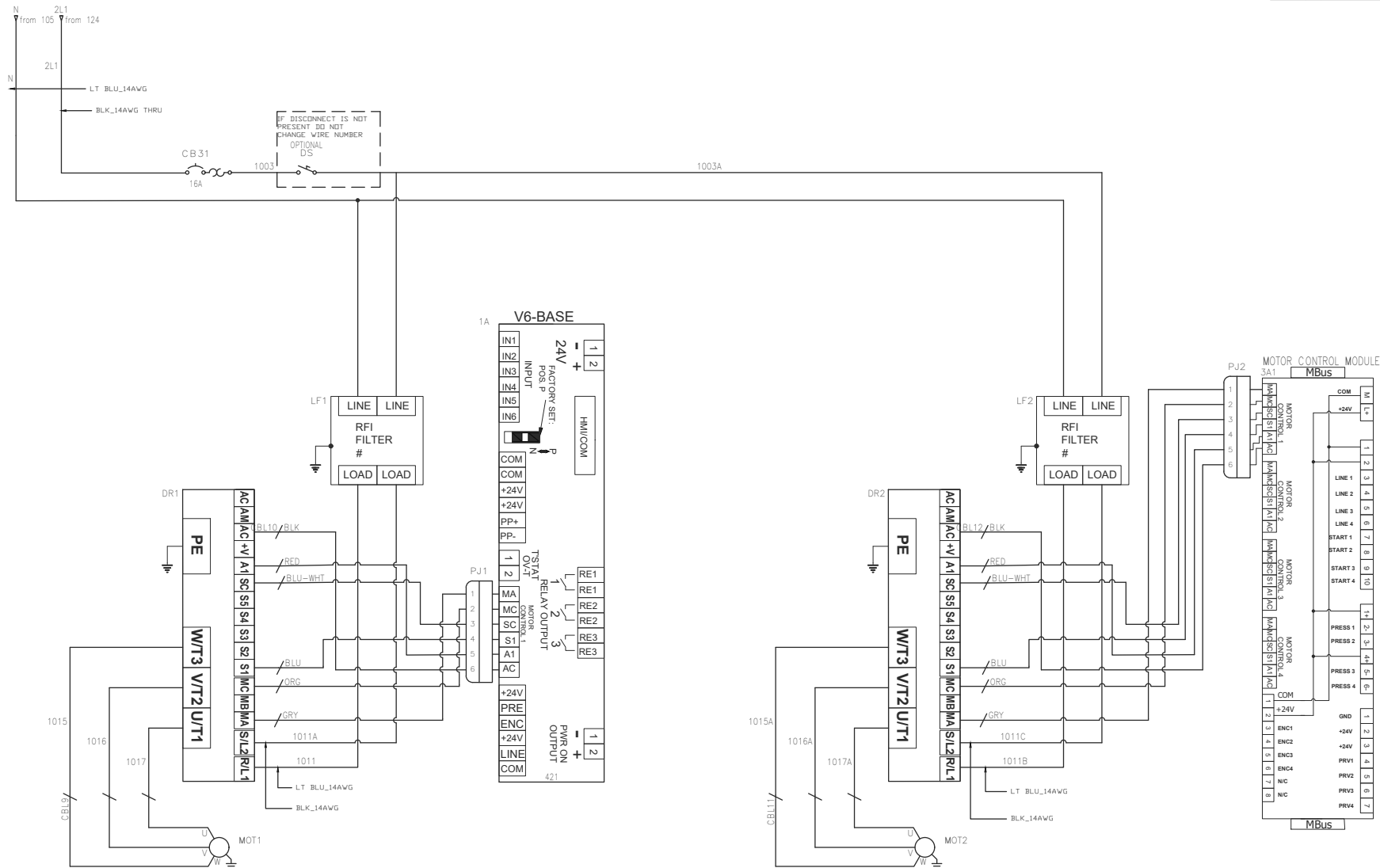

1000
1001
1002
1003
1004
1005
1006
1007
1008
1009
1010
1011
1012
1013
1014
1015
1016
1017
1018
1019
1020
1021
1022
1023
1024

ITEM	PART NUMBER	QTY	U/M	PARTS LIST	DESCRIPTION

DO NOT SCALE DRAWING		REFERENCES (UNLESS OTHERWISE SPECIFIED)		 TITLE: V6_M210 400V SH DRIVE INPUT	
COMPUTER DESCRIPTIONS (CHARACTERS)	NEXT ASSY	STATUS	REV		
FOR MACHINING STANDARDS AND DIMENSIONS, SEE ITW/DYNATEC SPEC. APPROV.	DATE	SOURCE	T	SCALE:	DRAWN BY: BFG CHECKED BY: -- APP'D BY: --
	08.08.13				SHEET 10 OF SHEETS 17 DRAWING NO. 820948

THIS DRAWING IS THE PROPERTY OF ITW/DYNATEC.
DO NOT REPRODUCE OR DISCLOSE TO
OTHERS WITHOUT EXPRESS WRITTEN
CONSENT OF ITW/DYNATEC.

REVISIONS					
REV.	BY	DESCRIPTION	DATE	BY	APPROVED

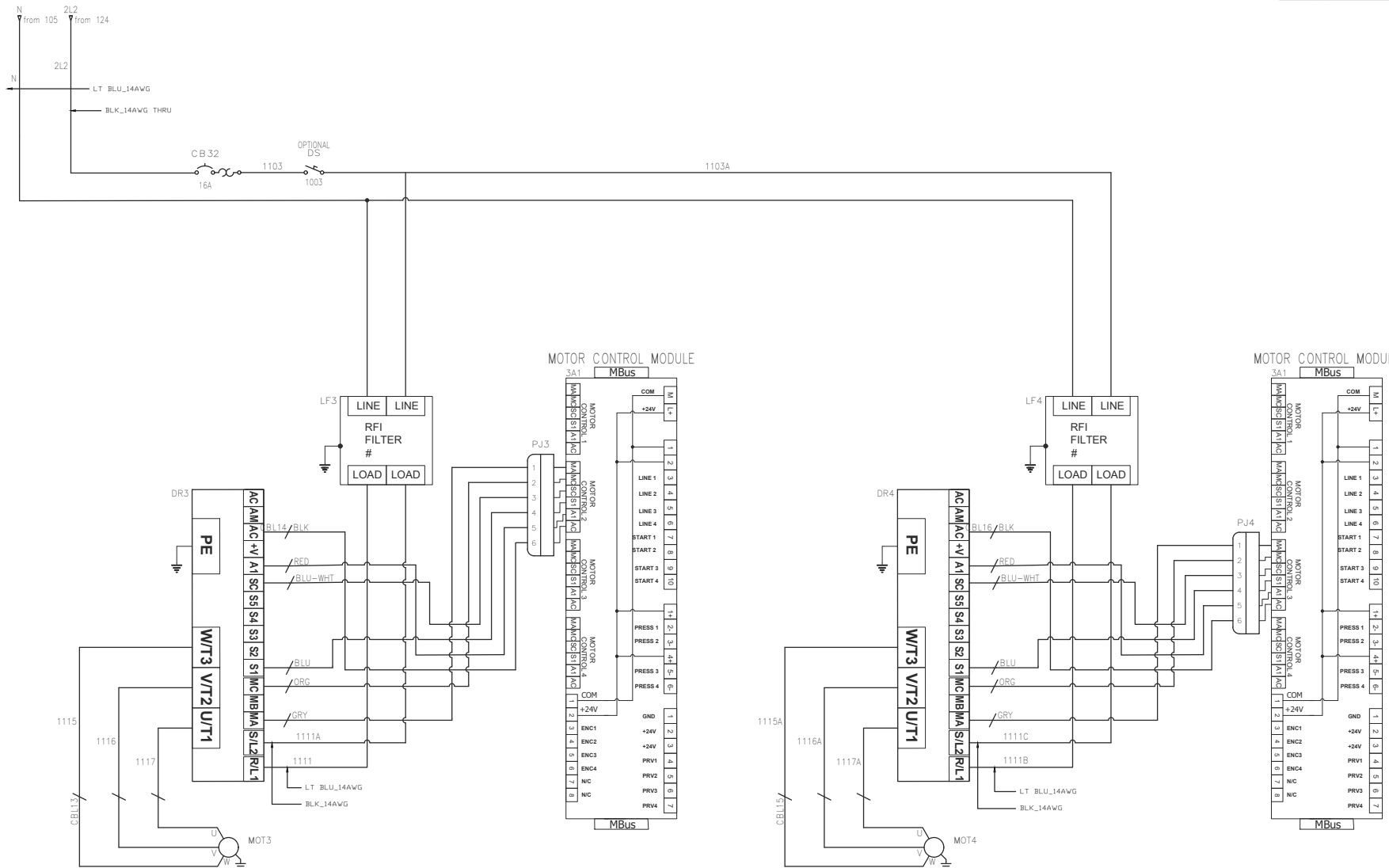

1100
1101
1102
1103
1104
1105
1106
1107
1108
1109
1110
1111
1112
1113
1114
1115
1116
1117
1118
1119
1120
1121
1122
1123
1124

ITEM	PART NUMBER	QTY	UOM	DESCRIPTION

DO NOT SCALE DRAWING		TOLERANCES (UNLESS OTHERWISE SPECIFIED)			
COMPUTER DESCRIPTIONS (CHARACTERS)	NEXT ASSY	STATUS	REV		
FOR MACHINING STANDARDS AND DIMENSIONS, SEE ITW/DYNATEC SPEC. A05050		SOURCE	TITLE	SCALE:	DRAWN BY:
		T	DRIVE INPUT	BFO	BFO
				DATE:	CHECKED BY:
				08.08.13	---
				SHEET	APPROVED BY:
				11	820948

THIS DRAWING IS THE PROPERTY OF INW/DYNATEC.
DO NOT REPRODUCE OR DISCLOSE TO
OTHERS WITHOUT EXPRESS WRITTEN
CONSENT OF INW/DYNATEC.

REVISIONS					
REV.	BY	DESCRIPTION	DATE	BY	APPROVED

1200
1201
1202
1203
1204
1205
1206
1207
1208
1209
1210
1211
1212
1213
1214
1215
1216
1217
1218
1219
1220
1221
1222
1223
1224

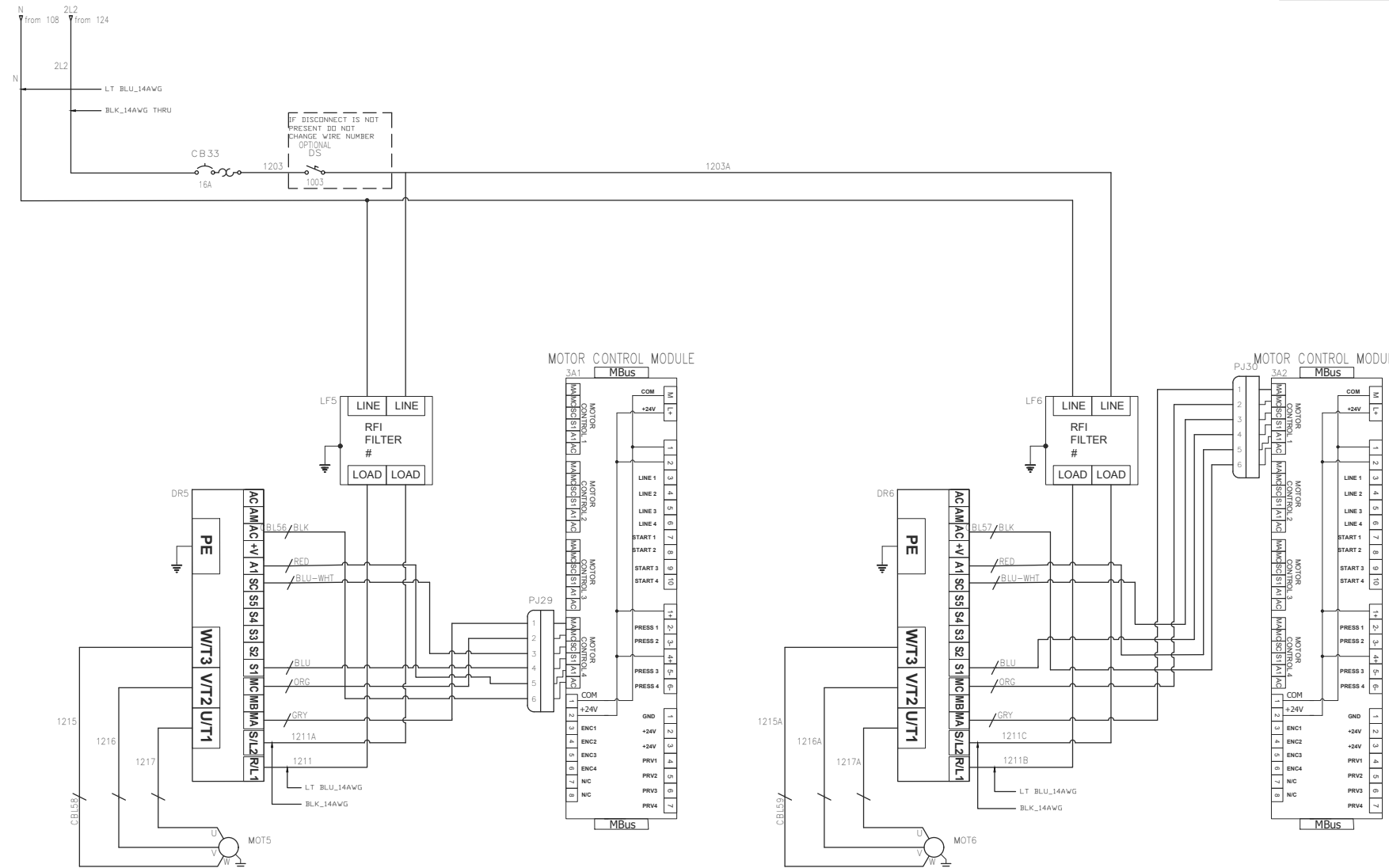

ITEM	PART NUMBER	QTY	U/M	PARTS LIST	DESCRIPTION

DO NOT SCALE DRAWING		TOLERANCES (UNLESS OTHERWISE SPECIFIED)			
COMPUTER DESCRIPTIONS (CHARACTERS)	NEXT ASSY	STATUS	REV		
FOR MACHINING STANDARDS AND DIMENSIONS, SEE INW/DYNATEC SPEC. APPROX		SOURCE	T	SCALE: B F Q	TITLE: V6, M210 400V SH DRIVE INPUT
DATE: 08.08.13	SHEET: 12	OF SHEETS: 17	DRAWN BY: B F Q	CHECKED BY: --	APPROVED BY: --
DRAWING NO: 820948					

THIS DRAWING IS THE PROPERTY OF ITW/DYNATEC.
DO NOT REPRODUCE OR DISCLOSE TO
OTHERS WITHOUT EXPRESS WRITTEN
CONSENT OF ITW/DYNATEC.

REVISIONS					
REV.	BY	DESCRIPTION	DATE	BY	APPROVED

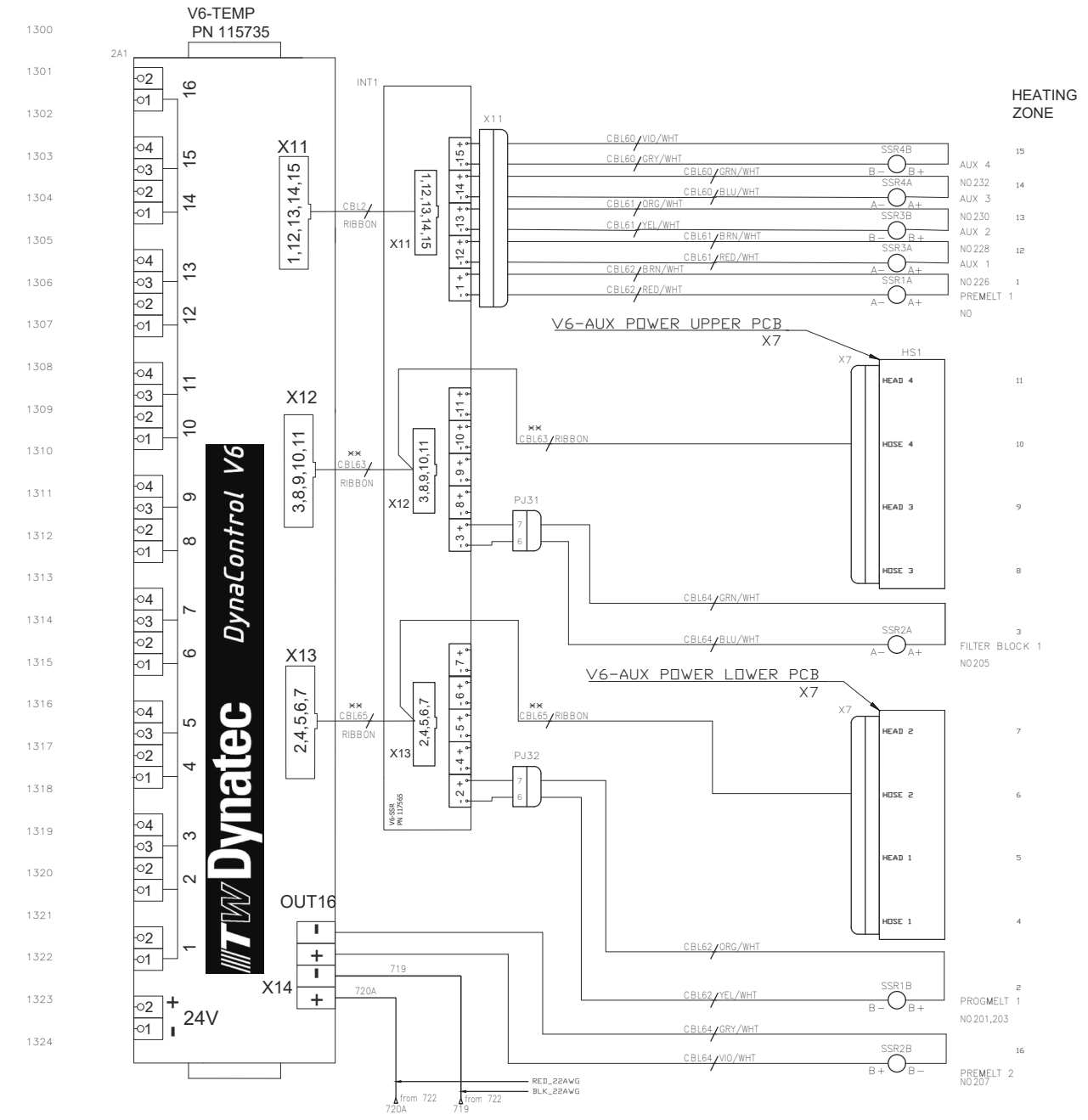

ITEM	PART NUMBER	QTY	UOM	DESCRIPTION

TOLERANCES (UNLESS OTHERWISE SPECIFIED)		ITW Dynatec <small>WARRANDERSVILLE, TN</small>	
COMPUTER DESCRIPTIONS (CHARACTERS)	DO NOT SCALE DRAWING	STATUS	DES
FOR MACHINING STANDARDS AND DIMENSIONS, SEE ITW/DYNATEC SPEC. APPROX.	NEXT ASSY	SCALE:	TITLE: V6_M210 400V SH SSR OUTPUTS
DATE: 08.08.13	SHEET 13 OF SHEETS 17	DRAWN BY: BFO	CHECKED BY: --
SOURCE: T	REV:	DATE:	APP'D BY:
DRAWING NO: 820948	SHEET 13 OF SHEETS 17	DATE: 08.08.13	DRAWN BY: BFO

THIS DRAWING IS THE PROPERTY OF ITW/DYNATEC.
DO NOT REPRODUCE OR DISCLOSE TO
OTHERS WITHOUT EXPRESS WRITTEN
CONSENT OF ITW/DYNATEC.

REVISIONS					
REV.	BY	DESCRIPTION	DATE	BY	APPROVED

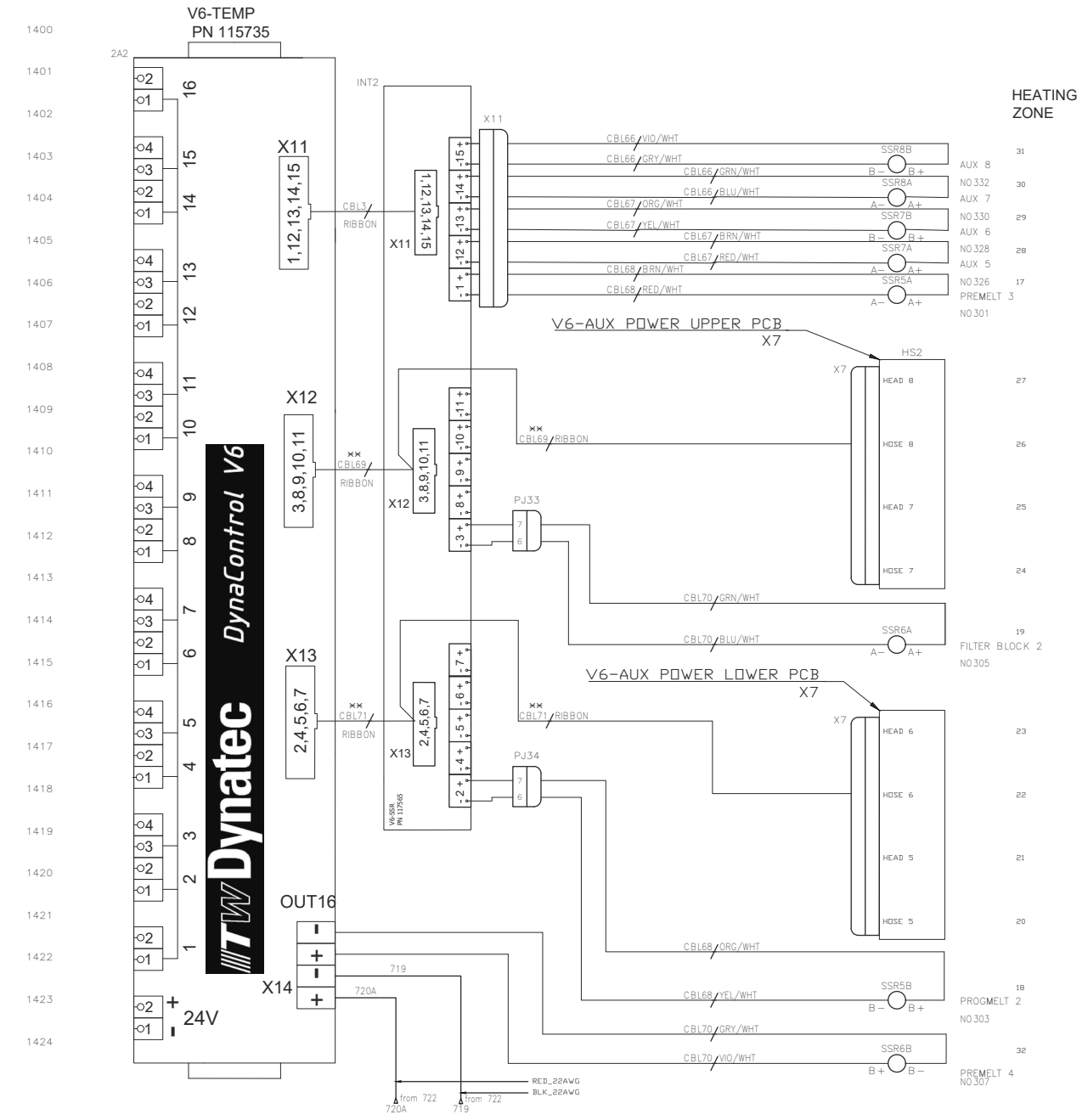

****NOTE**

CONFIGURATION SHOWN IS FOR IS FOR A SYSTEM WITH EIGHT OR MORE HOSE/HEAD CONNECTIONS REQUIRED WHERE CBL69 AND CBL71 ARE DUAL CABLES (P/N 823321). FOR A SYSTEM WITH LESS THAN EIGHT HOSE/HEAD CONNECTIONS, A SINGLE CABLE (P/N 823319) IS CONNECTED BETWEEN CONNECTOR X12/X13 ON V6-TEMP AND X12/X13 ON INT2 WHERE A PCB HOSE/HEAD CONNECTION IS NOT REQUIRED.

ITEM	PART NUMBER	QTY	UOM	DESCRIPTION

DO NOT SCALE DRAWING		TOLERANCES (UNLESS OTHERWISE SPECIFIED)		ITW Dynatec	
COMPUTER DESCRIPTIONS (CHARACTERS)		NEXT ASSY		TITLE: V6_M210 400V SH	
FOR MACHINING STANDARDS AND DIMENSIONS, SEE ITW/DYNATEC SPEC. ADDRESS		SOURCE: T		SSR OUTPUTS	
DATE: 08.08.13		SHEET: 14		OF SHEETS: 17	
DRAWN BY: BFO		CHECKED BY: --		APPROVED BY: --	
DRAWING NO: 820948					

THIS DRAWING IS THE PROPERTY OF ITW/DYNATEC.
DO NOT REPRODUCE OR DISCLOSE TO
OTHERS WITHOUT EXPRESS WRITTEN
CONSENT OF ITW/DYNATEC.

REVISIONS				
REV.	BY	DESCRIPTION	DATE	APP'D BY

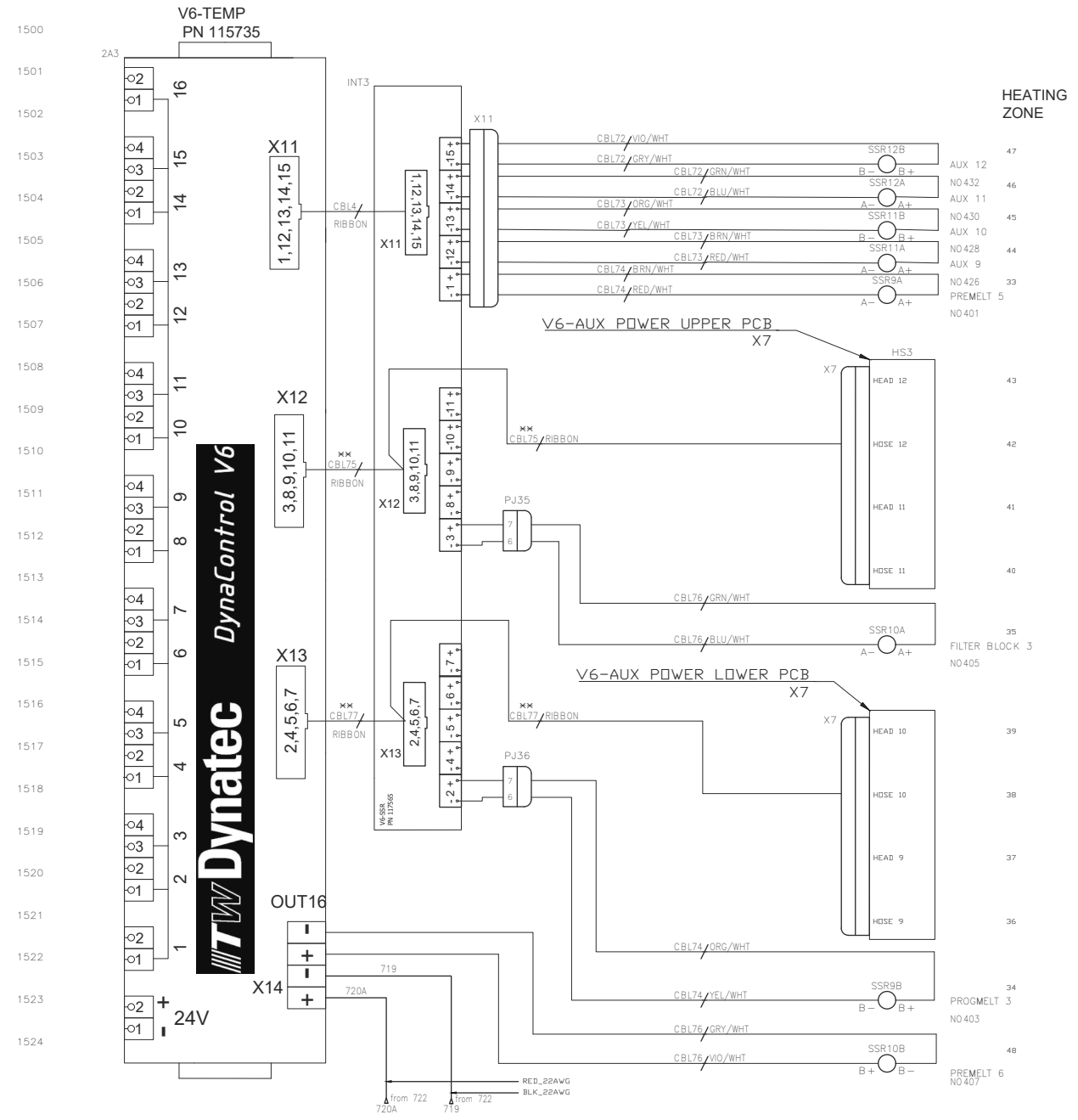

****NOTE**

CONFIGURATION SHOWN IS FOR IS FOR A SYSTEM WITH TWELVE HOSE/HEAD CONNECTIONS REQUIRED WHERE CBL75 AND CBL77 ARE DUAL CABLES (P/N 823321). FOR A SYSTEM WITH LESS THAN TWELVE HOSE/HEAD CONNECTIONS, A SINGLE CABLE (P/N 823319) IS CONNECTED BETWEEN CONNECTOR X12/X13 ON V6-TEMP AND X12/X13 ON INT3 WHERE A PCB HOSE/HEAD CONNECTION IS NOT REQUIRED.

ITEM	PART NUMBER	QTY	UOM	DESCRIPTION

DO NOT SCALE DRAWING		TOLERANCES (UNLESS OTHERWISE SPECIFIED)		ITW Dynatec	
COMPUTER DESCRIPTIONS IN CHARACTERS		NEXT ASSY		TITLE: V6_M210 400V SH	
FOR MACHINING STANDARDS AND DIMENSIONS, SEE ITW/DYNATEC SPEC. APPEND		DATE: 08.08.13		SSR OUTPUTS	
		DRAWN BY: BFO		CHECKED BY: --	
		SHEET 15		OF SHEETS 17	
				DRAWING NO: 820948	

THIS DRAWING IS THE PROPERTY OF ITW/DYNATEC.
DO NOT REPRODUCE OR DISCLOSE TO
OTHERS WITHOUT EXPRESS WRITTEN
CONSENT OF ITW/DYNATEC.

REVISIONS				
REV.	BY	DESCRIPTION	DATE	APPROVED

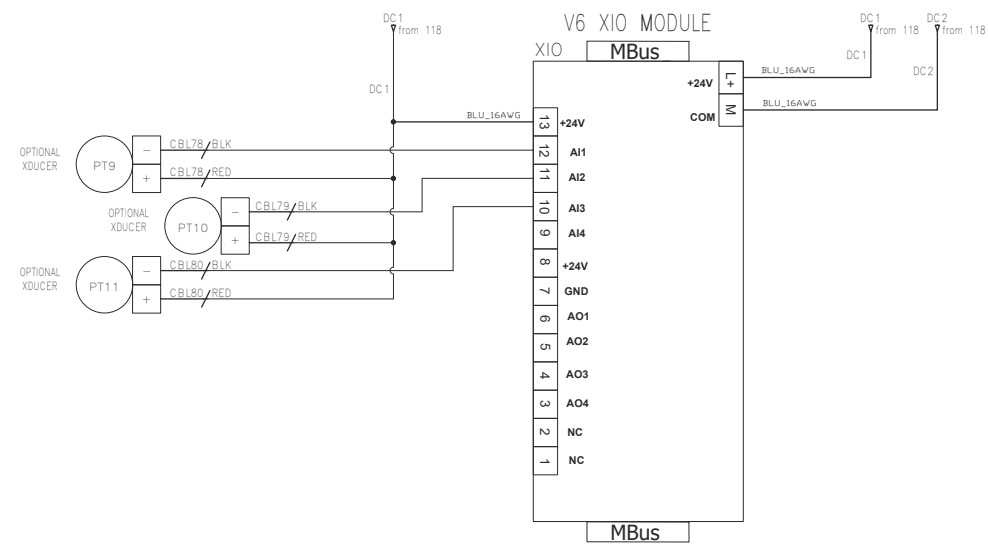
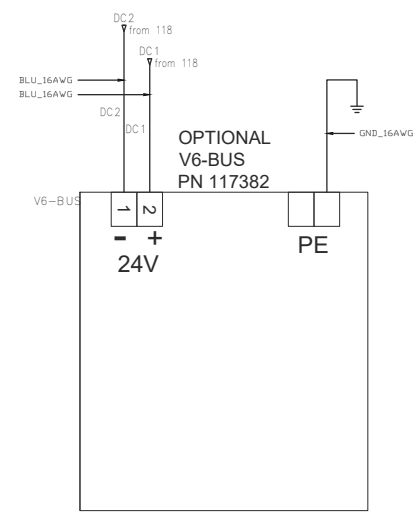

1600
1601
1602
1603
1604
1605
1606
1607
1608
1609
1610
1611
1612
1613
1614
1615
1616
1617
1618
1619
1620
1621
1622
1623
1624

ITEM	PART NUMBER	QTY	U/M	DESCRIPTION				
PARTS LIST								
DO NOT SCALE DRAWING				<table border="1"> <tr> <td>U/M</td> <td>SEE</td> </tr> <tr> <td>TITLE: V6_M210 400V SH</td> <td>OPTIONS</td> </tr> </table>	U/M	SEE	TITLE: V6_M210 400V SH	OPTIONS
U/M	SEE							
TITLE: V6_M210 400V SH	OPTIONS							
COMPUTER DESCRIPTIONS (CHARACTERS)		NEXT ASSY	STATUS	DATE: 08.08.13				
FOR MACHINING STANDARDS AND DIMENSIONS, SEE ITW/DYNATEC SPEC. ADDRESS		SOURCE	REV. T	SCALE: BFO				
				CHECKED BY: --				
				APPROVED BY:				
				DATE: 08.08.13				
				SHEET 16 OF SHEETS 17				
				DRAWING NO. 820948				



WABASHVILLE, TN

THIS DRAWING IS THE PROPERTY OF INV/DYNATEC.
DO NOT REPRODUCE OR DISCLOSE TO
OTHERS WITHOUT EXPRESS WRITTEN
CONSENT OF INV/DYNATEC.

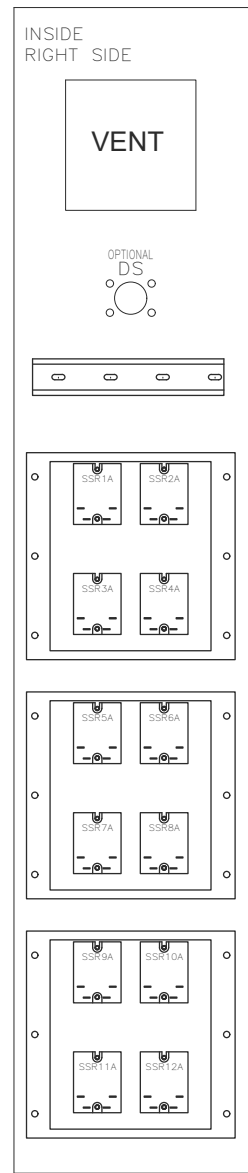
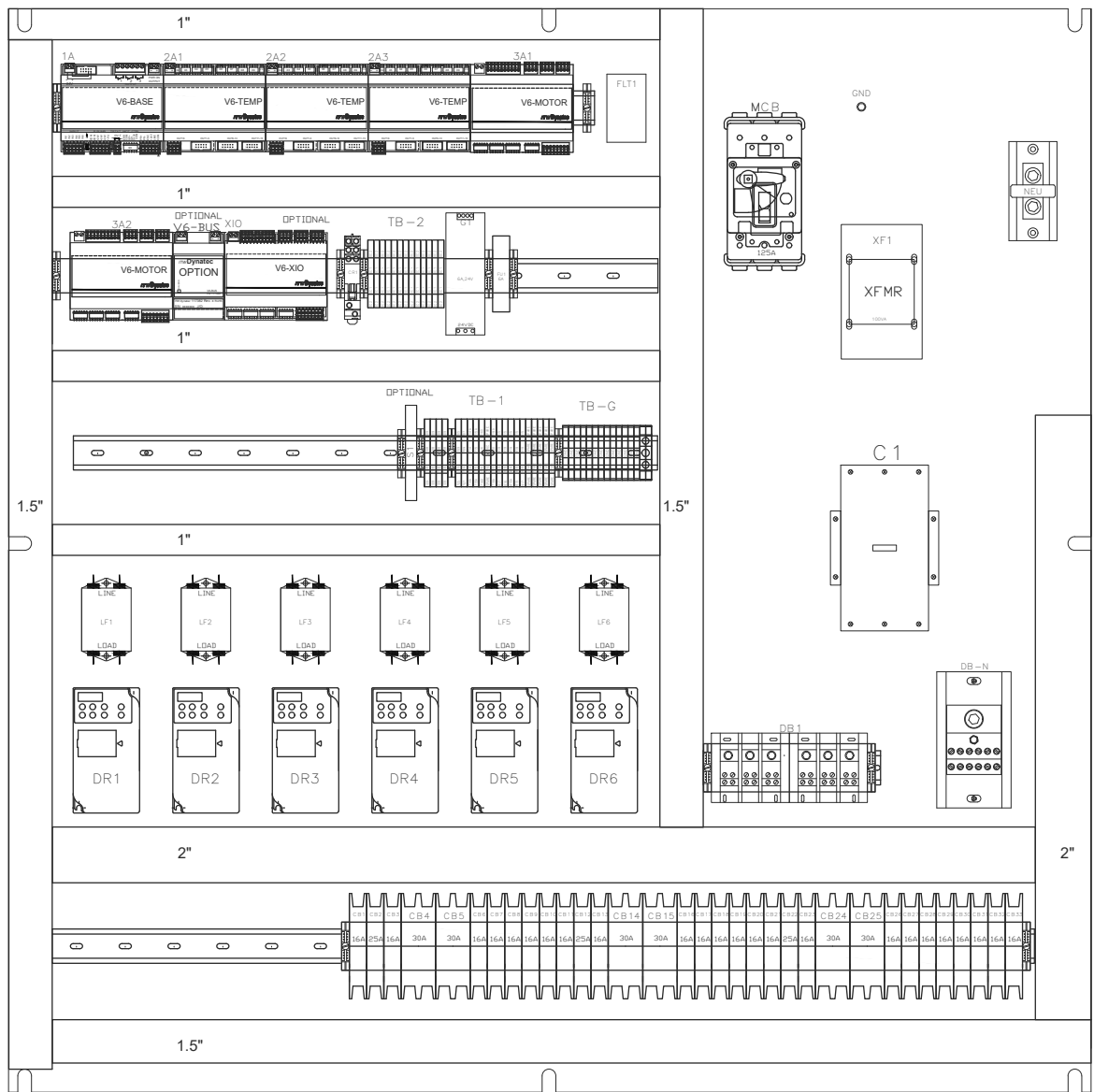
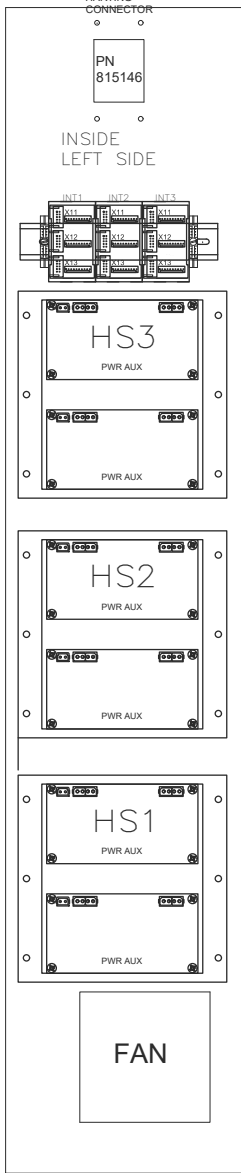

REVISIONS																																																																																																																				
REV.	BY	DESCRIPTION	DATE	BY APPROVED																																																																																																																
<table border="1"> <thead> <tr> <th colspan="2">TB-1</th> <th colspan="2">TB-2</th> </tr> <tr> <th>LOWER TERMINAL</th> <th>UPPER TERMINAL</th> <th>LOWER TERMINAL</th> <th>UPPER TERMINAL</th> </tr> </thead> <tbody> <tr> <td>109 WIRE NO</td> <td>240VAC</td> <td>108 WIRE NO</td> <td>240VAC</td> </tr> <tr> <td>109</td> <td>240VAC</td> <td>108</td> <td>240VAC</td> </tr> <tr> <td>109</td> <td>240VAC</td> <td>108</td> <td>240VAC</td> </tr> <tr> <td>109</td> <td>240VAC</td> <td>108</td> <td>240VAC</td> </tr> <tr> <td>705</td> <td>STBY</td> <td>705</td> <td>STBY</td> </tr> <tr> <td>707</td> <td>LNIB</td> <td>709</td> <td>LNIA</td> </tr> <tr> <td>714A</td> <td>RLIB</td> <td>714</td> <td>RLII</td> </tr> <tr> <td>715</td> <td>ALF</td> <td>715</td> <td>ALI</td> </tr> <tr> <td>716B</td> <td>LLF</td> <td>716</td> <td>LLI</td> </tr> <tr> <td>SPARE</td> <td>SPARE</td> <td>716C</td> <td>RTS</td> </tr> <tr> <td>719A</td> <td>SP1B</td> <td>720</td> <td>SP1A</td> </tr> <tr> <td>817</td> <td>LN2B</td> <td>819</td> <td>LN2A</td> </tr> <tr> <td>818</td> <td>LN3B</td> <td>819</td> <td>LN3A</td> </tr> <tr> <td>818A</td> <td>LN4B</td> <td>819</td> <td>LN4A</td> </tr> <tr> <td>819</td> <td>LN5B</td> <td>819</td> <td>LN5A</td> </tr> <tr> <td>819</td> <td>LN6B</td> <td>819</td> <td>LN6A</td> </tr> <tr> <td>SPARE</td> <td>SPARE</td> <td>SPARE</td> <td>SPARE</td> </tr> <tr> <td>SPARE</td> <td>SPARE</td> <td>SPARE</td> <td>SPARE</td> </tr> <tr> <td>SPARE</td> <td>SPARE</td> <td>SPARE</td> <td>SPARE</td> </tr> <tr> <td>SPARE</td> <td>SPARE</td> <td>SPARE</td> <td>SPARE</td> </tr> <tr> <td>SPARE</td> <td>SPARE</td> <td>SPARE</td> <td>SPARE</td> </tr> <tr> <td>SPARE</td> <td>SPARE</td> <td>SPARE</td> <td>SPARE</td> </tr> <tr> <td colspan="2">TB-3</td> <td colspan="2">TB-4</td> </tr> <tr> <th>LOWER TERMINAL</th> <th>UPPER TERMINAL</th> <th>LOWER TERMINAL</th> <th>UPPER TERMINAL</th> </tr> <tr> <td>102 WIRE NO</td> <td>0VDC</td> <td>101 WIRE NO</td> <td>+24VDC</td> </tr> <tr> <td>102</td> <td>0VDC</td> <td>101</td> <td>+24VDC</td> </tr> </tbody> </table>					TB-1		TB-2		LOWER TERMINAL	UPPER TERMINAL	LOWER TERMINAL	UPPER TERMINAL	109 WIRE NO	240VAC	108 WIRE NO	240VAC	109	240VAC	108	240VAC	109	240VAC	108	240VAC	109	240VAC	108	240VAC	705	STBY	705	STBY	707	LNIB	709	LNIA	714A	RLIB	714	RLII	715	ALF	715	ALI	716B	LLF	716	LLI	SPARE	SPARE	716C	RTS	719A	SP1B	720	SP1A	817	LN2B	819	LN2A	818	LN3B	819	LN3A	818A	LN4B	819	LN4A	819	LN5B	819	LN5A	819	LN6B	819	LN6A	SPARE	SPARE	SPARE	SPARE	SPARE	SPARE	SPARE	SPARE	SPARE	SPARE	SPARE	SPARE	SPARE	SPARE	SPARE	SPARE	SPARE	SPARE	SPARE	SPARE	SPARE	SPARE	SPARE	SPARE	TB-3		TB-4		LOWER TERMINAL	UPPER TERMINAL	LOWER TERMINAL	UPPER TERMINAL	102 WIRE NO	0VDC	101 WIRE NO	+24VDC	102	0VDC	101	+24VDC
TB-1		TB-2																																																																																																																		
LOWER TERMINAL	UPPER TERMINAL	LOWER TERMINAL	UPPER TERMINAL																																																																																																																	
109 WIRE NO	240VAC	108 WIRE NO	240VAC																																																																																																																	
109	240VAC	108	240VAC																																																																																																																	
109	240VAC	108	240VAC																																																																																																																	
109	240VAC	108	240VAC																																																																																																																	
705	STBY	705	STBY																																																																																																																	
707	LNIB	709	LNIA																																																																																																																	
714A	RLIB	714	RLII																																																																																																																	
715	ALF	715	ALI																																																																																																																	
716B	LLF	716	LLI																																																																																																																	
SPARE	SPARE	716C	RTS																																																																																																																	
719A	SP1B	720	SP1A																																																																																																																	
817	LN2B	819	LN2A																																																																																																																	
818	LN3B	819	LN3A																																																																																																																	
818A	LN4B	819	LN4A																																																																																																																	
819	LN5B	819	LN5A																																																																																																																	
819	LN6B	819	LN6A																																																																																																																	
SPARE	SPARE	SPARE	SPARE																																																																																																																	
SPARE	SPARE	SPARE	SPARE																																																																																																																	
SPARE	SPARE	SPARE	SPARE																																																																																																																	
SPARE	SPARE	SPARE	SPARE																																																																																																																	
SPARE	SPARE	SPARE	SPARE																																																																																																																	
SPARE	SPARE	SPARE	SPARE																																																																																																																	
TB-3		TB-4																																																																																																																		
LOWER TERMINAL	UPPER TERMINAL	LOWER TERMINAL	UPPER TERMINAL																																																																																																																	
102 WIRE NO	0VDC	101 WIRE NO	+24VDC																																																																																																																	
102	0VDC	101	+24VDC																																																																																																																	

TAGS	PART NUMBER	DESCRIPTION
1A	119833	V6 BASE MODULE
2A1,2A2,2A3	115735	V6 BUS TERMINATION
2A1,2A2,2A3	116823	V6 TEMPERATURE MODULE
1A,3A2	881748	V6 MOTOR MODULE
C1	881748	MAIN CONTACTOR
	882087	DP30 FIB CONTACTOR
	882087	SUPPRESSOR FUSE UNIT
C1B1,4,6-11,13,16-21,23,27-33	811300	C-B16A,1 PILE
C1B1,6,22	882050	C-B20A1 PILE
C1B1,5,14,15,24,25	811391	C-B,50A,2 PILE
CR1,2	882247	CONTROL RELAY
DB1	881749	DISTRIBUTION BLOCK
DB-N	884890	DB NEUTRAL DISTRIBUTION BLOCK
DR1-6	815823	VF,TRIP
FL1	848185	F FUSE BLOCK,LPCC
FL1	880929	FUSE,AMPS,1,PCB
GA	119156	POWER SUPPLY,GAMP,24V
GN1	882900	GROUND LUG
HMI	118125	V6 HMI
HST-3	882206	V6 POWER BOARD
LF1-6	117456	FINE FILTER
MCB	881937	C-B,125A,3 PILE MAIN CIRCUIT BREAKER
	881937	C-B,125A,3 PILE MAIN CIRCUIT BREAKER
	881937	C-B,125A,3 PILE MAIN CIRCUIT BREAKER
NEU	114286	DUAL CHANNEL SSR
SSR1-12	112531	DUAL TERMINAL
VB-BUS	117288	V6 COMMUNICATION MODULE
X10	882400	RT 120 TRANSFORMER
X11	882403	DP30 SHIELD FOR TRANSFORMER
X12	117648	V6 XII MIDDLE

NOTE:
IF DRIVE DISCONNECT IS INCLUDED MOUNT ON
RIGHT WALL BELOW EXHAUST VENT

ITEM	PART NUMBER	QTY	UOM	DESCRIPTION
PARTS LIST				
TOLERANCES (UNLESS OTHERWISE SPECIFIED)				
TITLE: V6_M210 400V SH LAYOUT				
SCALE: DRAWN BY: BFG CHECKED BY: APPD BY:				
DATE: 08.08.13 SHEET 17 OF 17 DRAWING NO: 820948				

11.9 Schematics M210 V6 400V Dual Hopper, PN 821070T

THIS DRAWING IS THE PROPERTY OF INV/DYNATEC.
DO NOT REPRODUCE OR DISCLOSE TO
OTHERS WITHOUT EXPRESS WRITTEN
CONSENT OF INV/DYNATEC.

REVISIONS					
REV.	BY	DESCRIPTION	DATE	BY	APPROVED
17050	L	CONVERTED TO ACADE	07.31.17	BFG	
ECN702	M	CORRECTIONS PER ASSEMBLY	09.22.17	BFG	
8146	N	ADDED DRIVE DISCONNECT	11.26.18	BFG	
ECN576	P	ADD GND WIRE TO XF1 SECONDARY	09.27.19	DJT	
ECN822	Q	REVISE SSR CABLE DETAIL (SHT 13/14/15)	02.24.20	DJT	
ECN849	R	CORRECT DV3/4 WIRING (SHT 9/10)	03.11.20	DJT	
ECN1239	S	ADD VOLTAGE TO XF1	03.11.21	JJB	
ECN1309	T	REVISE FLT1 AND FLT2	05.17.21	JJB	

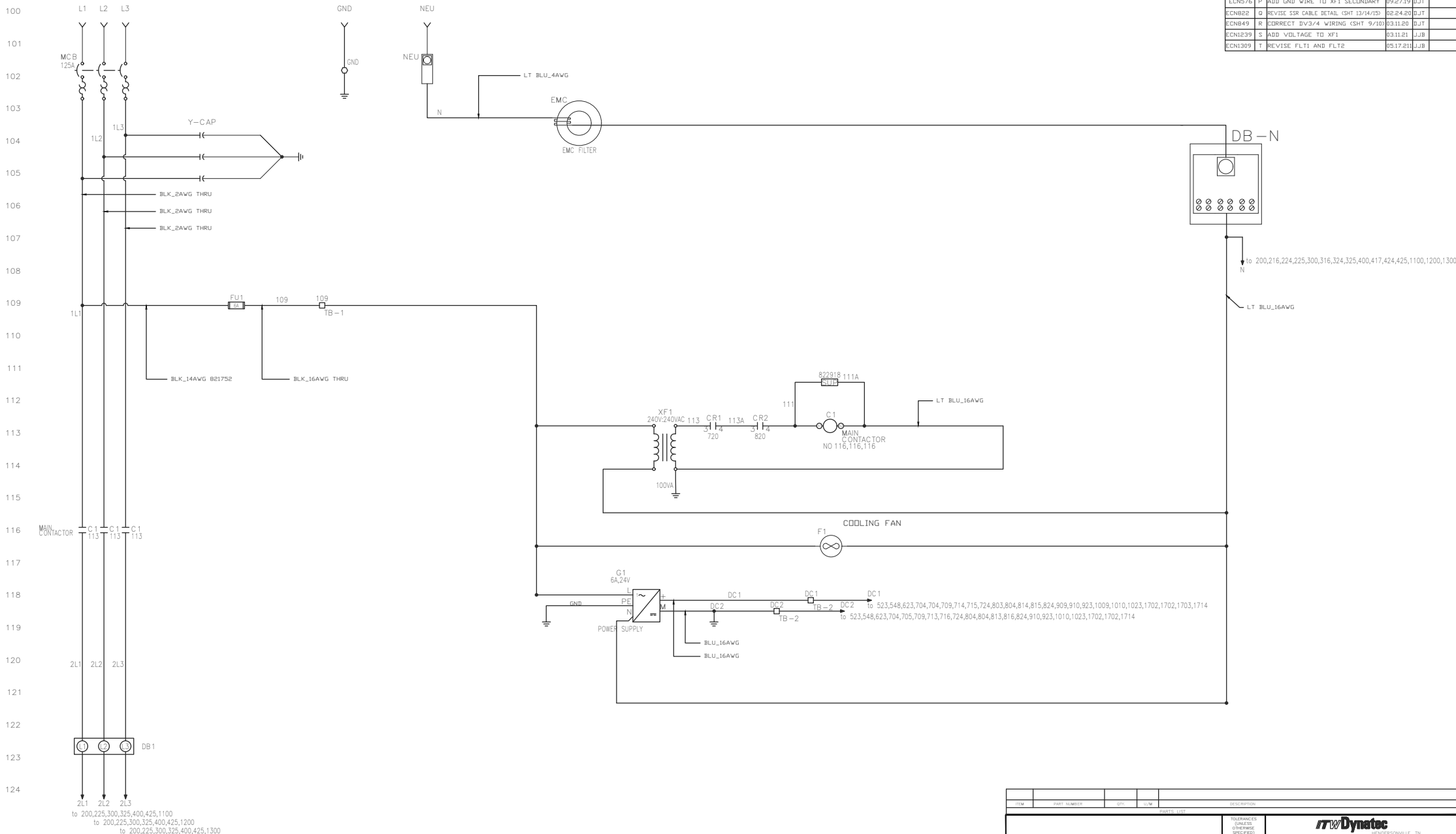

to 200,225,300,325,400,425,1100
to 200,225,300,325,400,425,1200
to 200,225,300,325,400,425,1300

ITEM	PART NUMBER	QTY	UOM	DESCRIPTION
PARTS LIST				
TOLERANCES (UNLESS OTHERWISE SPECIFIED)				
U/M				
TITLE: V6, M210, 400V, DH				
POWER DISTRIBUTION				
DO NOT SCALE DRAWING				
STATUS: DES				
SCALE: BFG				
CHECKED BY: ---				
APPROVED BY: ---				
DATE: 08.08.13				
SHEET 1 OF SHEETS 18				
DRAWING NO. 821070				

THIS DRAWING IS THE PROPERTY OF IN/DMATEC.
DO NOT REPRODUCE OR DISCLOSE TO
OTHERS WITHOUT EXPRESS WRITTEN
CONSENT OF IN/DMATEC.

REVISIONS					
REV.	BY	DESCRIPTION	DATE	BY	APPROVED

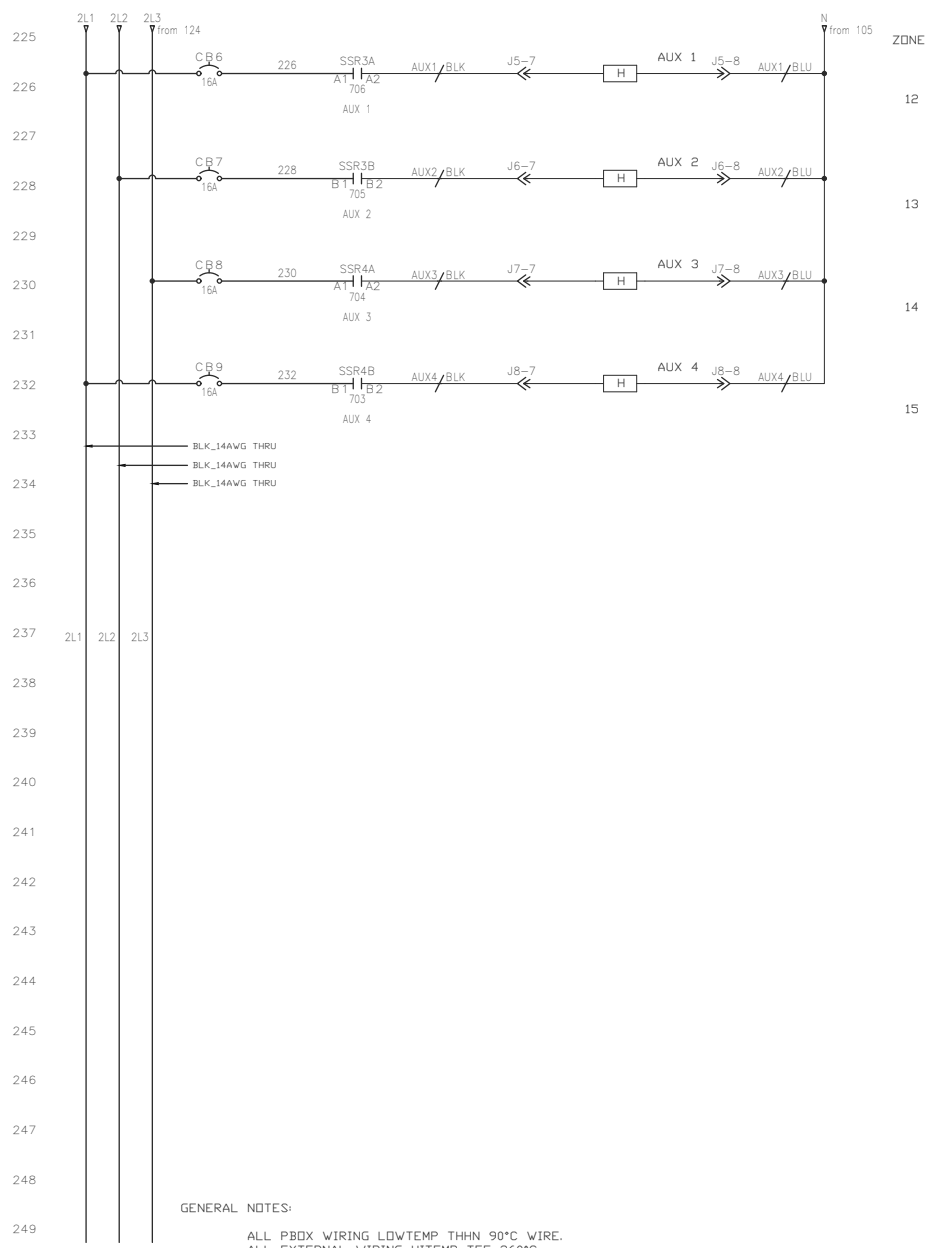
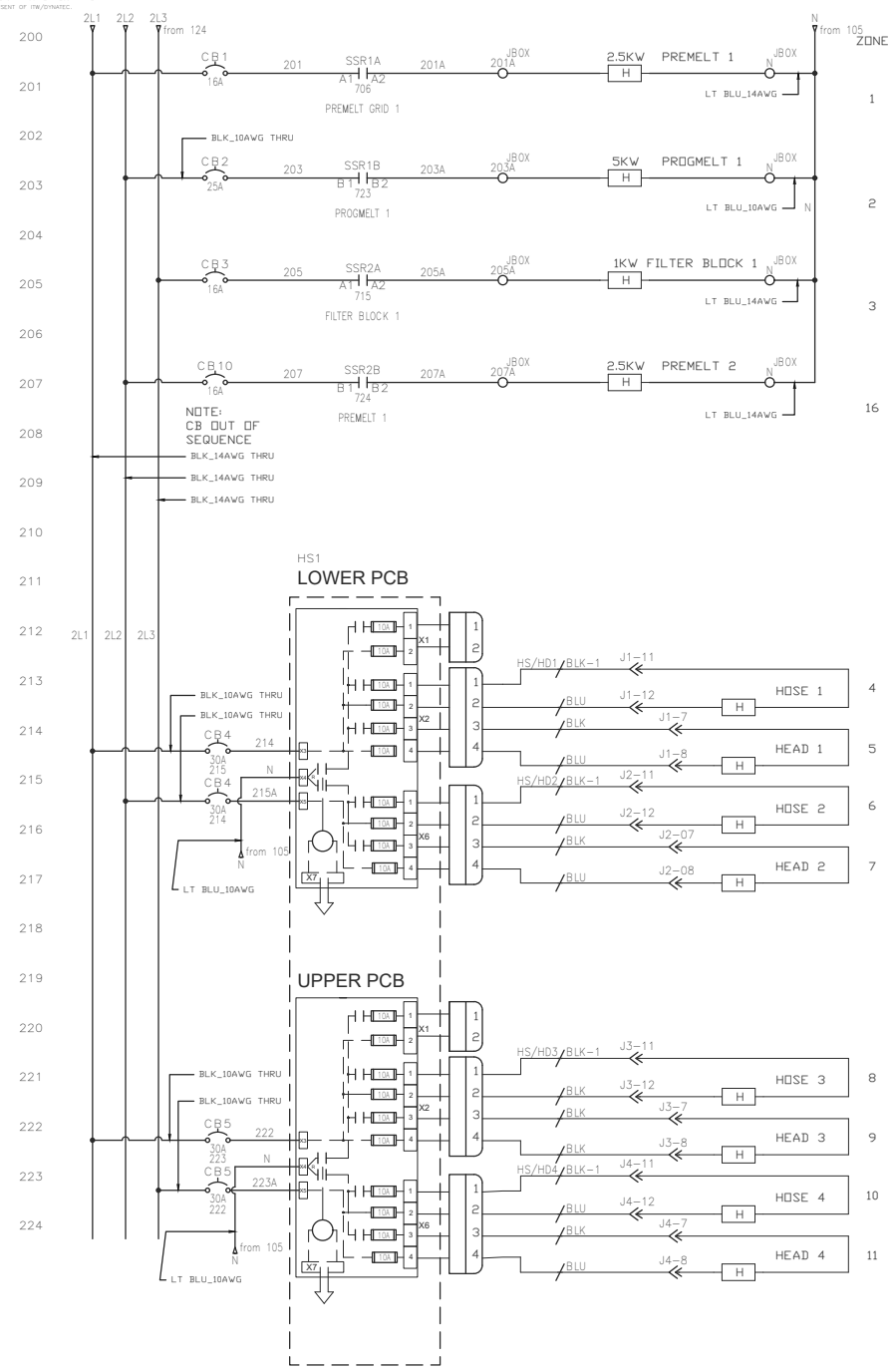

GENERAL NOTES:

- ALL PBOX WIRING LOWTEMP THHN 90°C WIRE.
- ALL EXTERNAL WIRING HITEMP TFE 260°C OR EQUIV.
- DENOTES TERMINAL IN PBOX
- DENOTES TERMINAL IN JBOX
- APPLY WIRE NUMBERS TO BOTH ENDS OF WIRE.
- DENOTES DEVICES EXTERNAL TO PBOX.
- WIRE ALL GROUND CONNECTIONS PER DRAWING 804704.
- THIS IS A GENERAL SCHEMATIC. NOT ALL DEVICES MAY BE PRESENT. SEE ORDER FOR NUMBER OF HOSES, HEADS, AUX, AND MOTORS.

ITEM	PART NUMBER	QTY	UOM	DESCRIPTION
PARTS LIST				
TOLERANCES (UNLESS OTHERWISE SPECIFIED)				
DO NOT SCALE DRAWING		STATUS		DESIGN
COMPUTER DESCRIPTIONS (CHARACTERS)		NEXT ASSY		SCALE: DRAWN BY: CHECKED BY: APP'D BY:
FOR MACHINING STANDARDS AND DIMENSIONS, SEE IN/DMATEC SPEC. A03539		SOURCE		DATE: 08.08.13 SHEET 2 OF SHEETS 18 DRAWING NO. 821070



TITLE: V6, M210, 400V, DH
HEATER CIRCUITS
IN/DMATEC, INC. MEMPHIS, TN

THIS DRAWING IS THE PROPERTY OF INV/DYNATEC.
DO NOT REPRODUCE OR DISCLOSE TO
OTHERS WITHOUT EXPRESS WRITTEN
CONSENT OF INV/DYNATEC.

REVISIONS					
REV.	BY	DESCRIPTION	DATE	BY	APPROVED

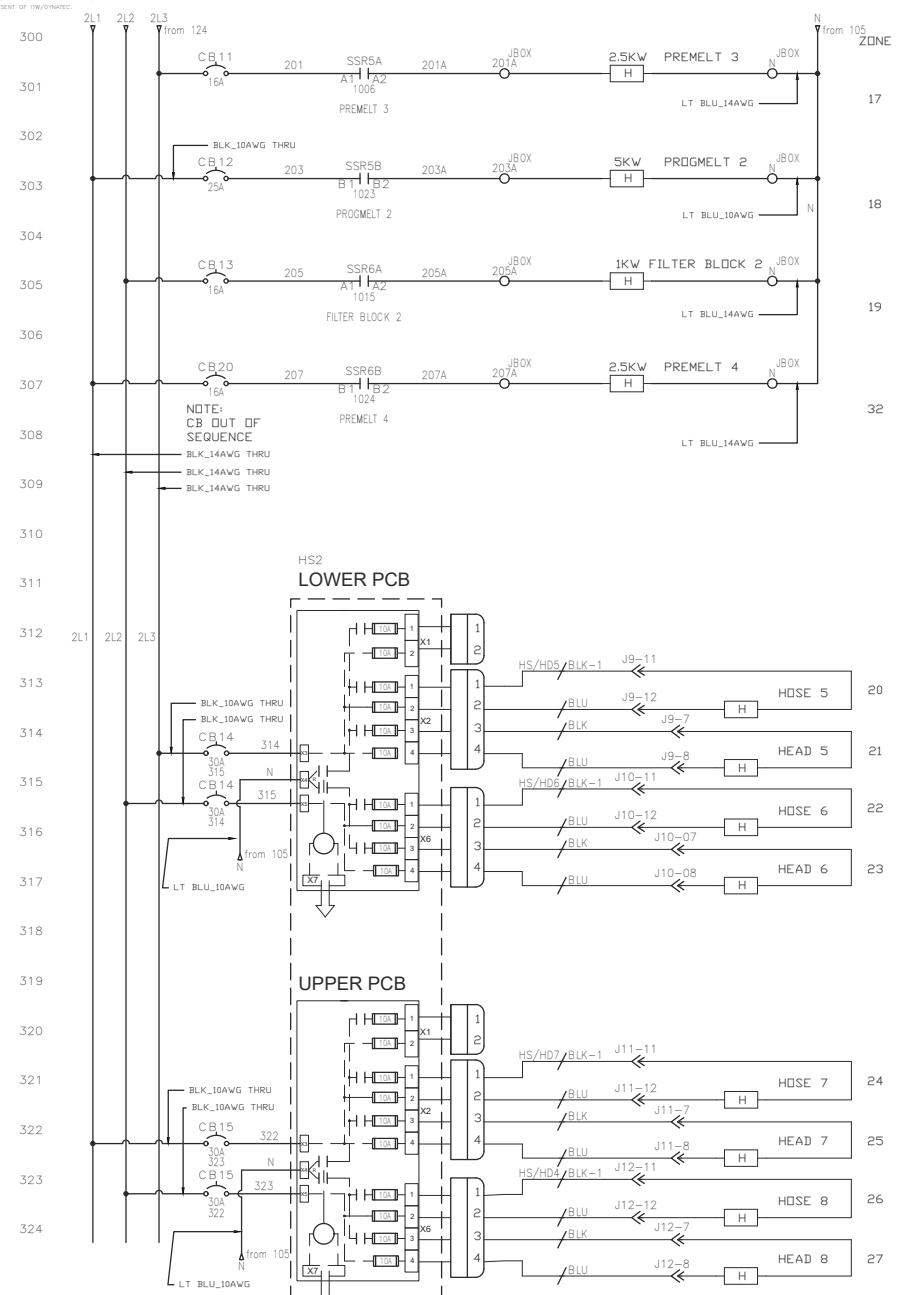

LOWER PCB

UPPER PCB

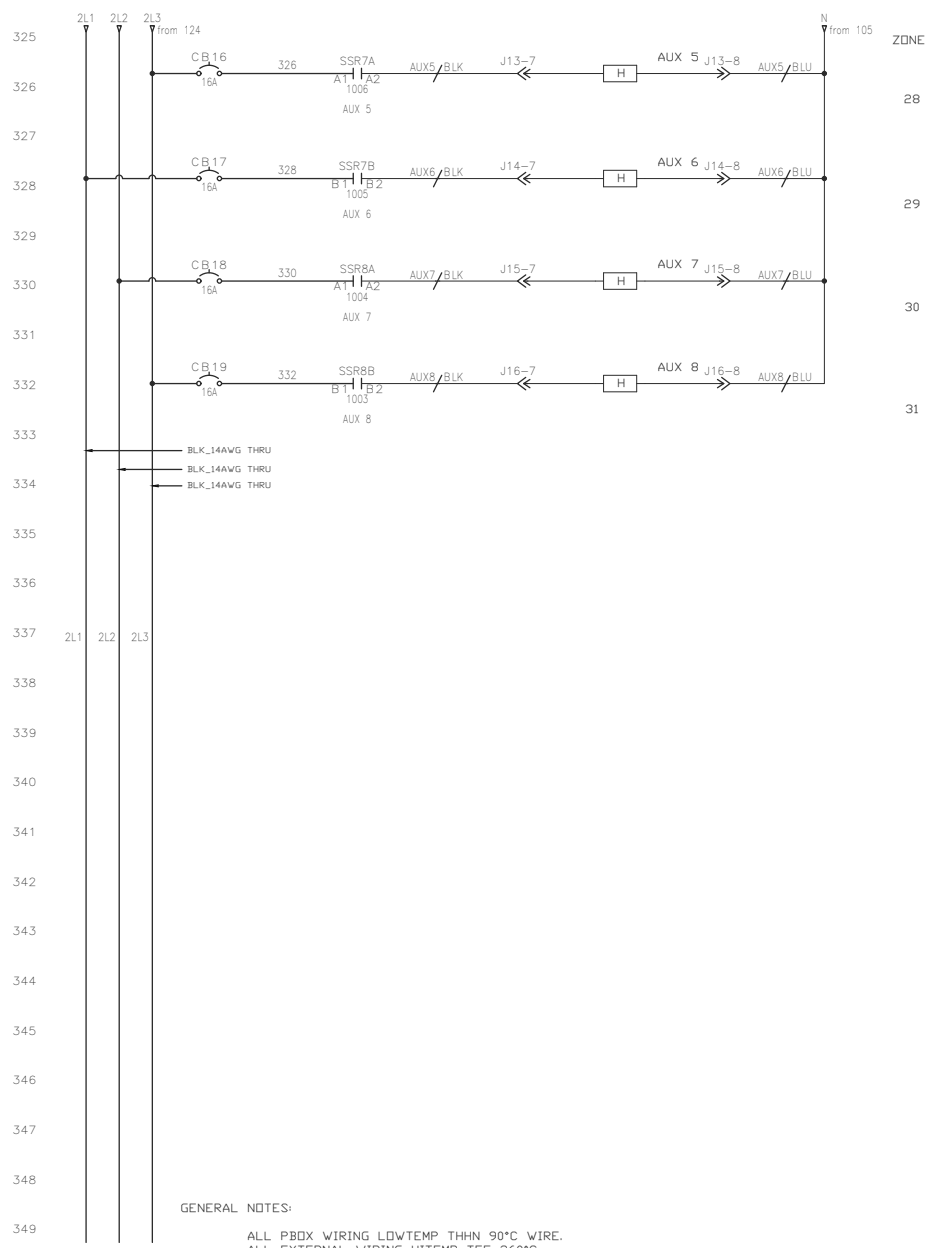
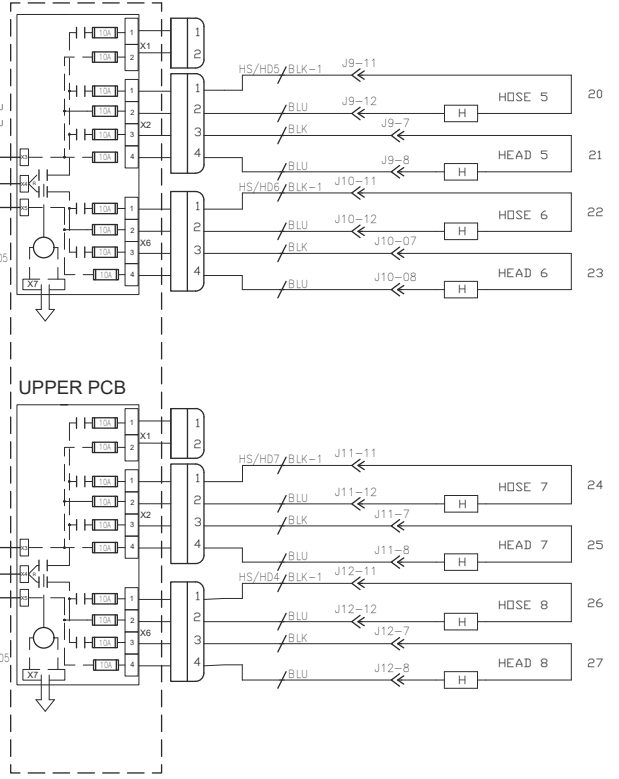

GENERAL NOTES:

- ALL PBOX WIRING LOWTEMP THHN 90°C WIRE.
- ALL EXTERNAL WIRING HITEMP TFE 260°C OR EQUIV.
- DENOTES TERMINAL IN PBOX
- DENOTES TERMINAL IN JBOX
- APPLY WIRE NUMBERS TO BOTH ENDS OF WIRE.
- DENOTES DEVICES EXTERNAL TO PBOX.
- WIRE ALL GROUND CONNECTIONS PER DRAWING 804704.
- THIS IS A GENERAL SCHEMATIC. NOT ALL DEVICES MAY BE PRESENT. SEE ORDER FOR NUMBER OF HOSES, HEADS, AUX, AND MOTORS.

ITEM	PART NUMBER	QTY	UOM	PARTS LIST	DESCRIPTION

DO NOT SCALE DRAWING		TOLERANCES (UNLESS OTHERWISE SPECIFIED)			
COMPUTER DESCRIPTIONS (CHARACTERS)	NEXT ASSY	STATUS	DES		
FOR MACHINING STANDARDS AND DIMENSIONS, SEE INV/DYNATEC SPEC. A03539		SCALE:	T	TITLE: V6, M210, 400V, DH HEATER CIRCUITS	DATE: 08.08.13
		DRAWN BY: BFO	CHECKED BY:	APPROV BY:	SHEET 3 OF SHEETS 18
		DATE: 08.08.13			DRAWING NO: 821070

THIS DRAWING IS THE PROPERTY OF TRW/DYNATEC.
DO NOT REPRODUCE OR DISCLOSE TO
OTHERS WITHOUT EXPRESS WRITTEN
CONSENT OF TRW/DYNATEC.

REVISIONS					
REV.	BY	DESCRIPTION	DATE	BY	APPROVED

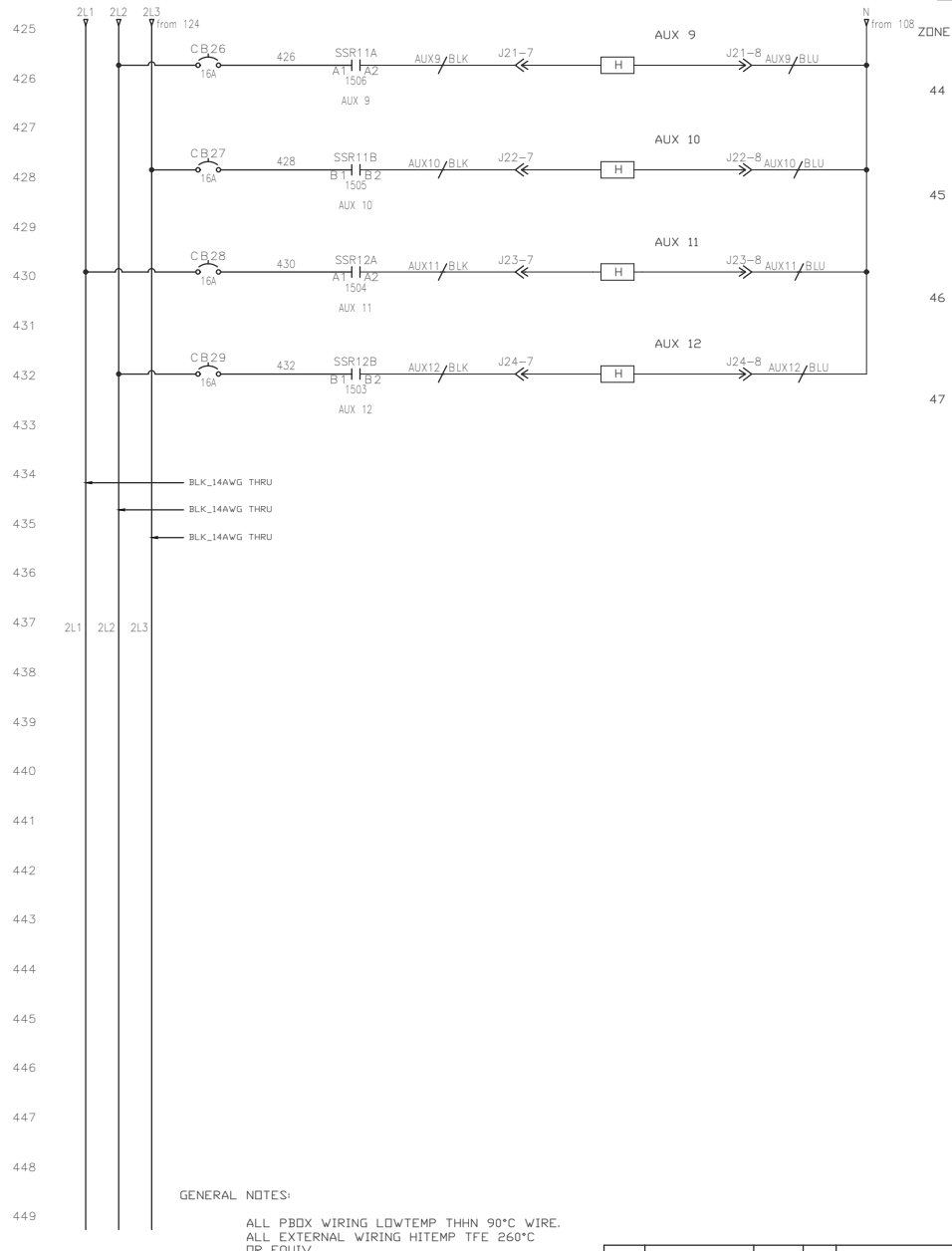
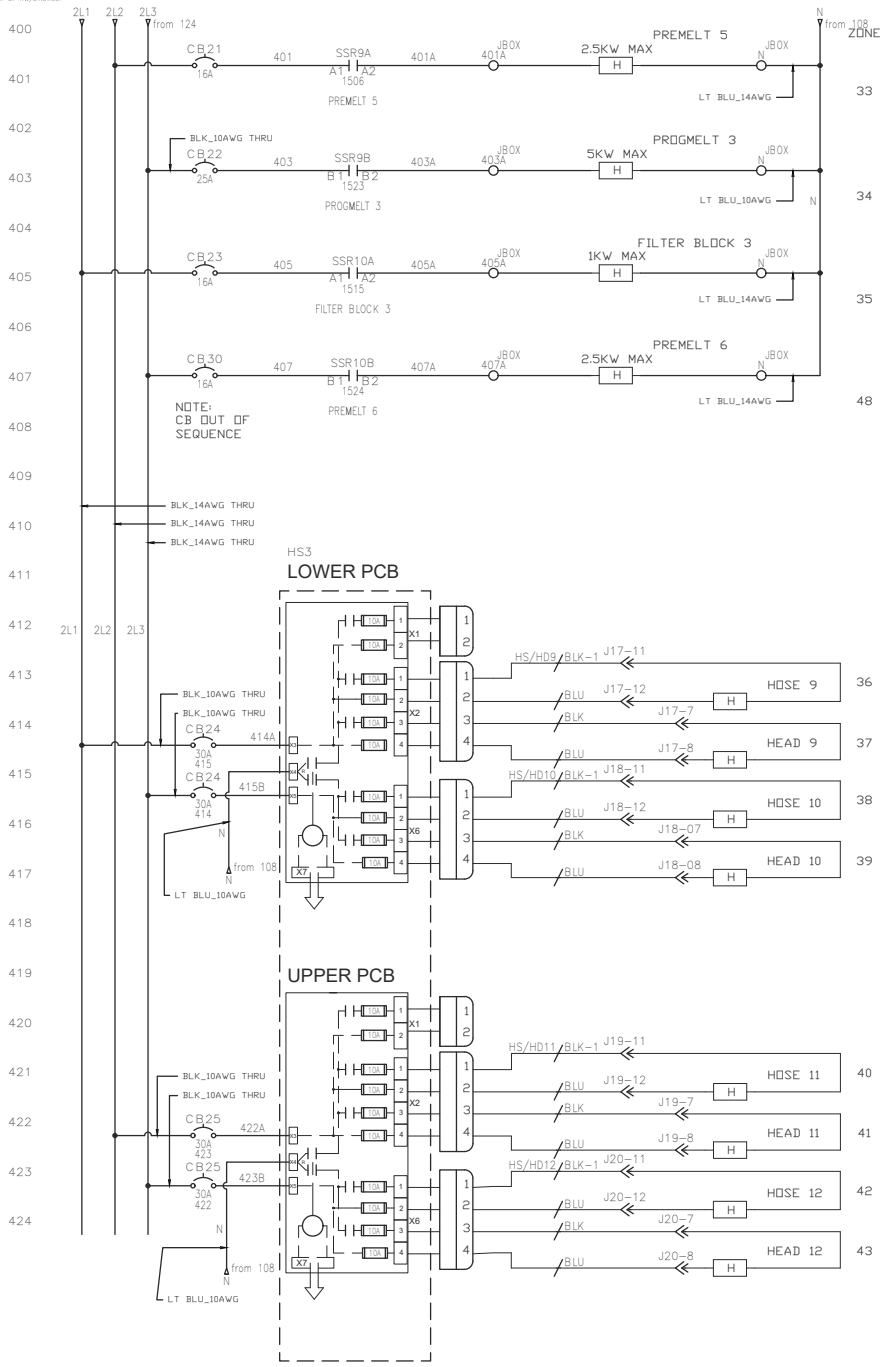

GENERAL NOTES:

- ALL PBOX WIRING LOWTEMP THHN 90°C WIRE.
- ALL EXTERNAL WIRING HITEMP TFE 260°C OR EQUIV.
- DENOTES TERMINAL IN PBOX
- DENOTES TERMINAL IN JBOX
- APPLY WIRE NUMBERS TO BOTH ENDS OF WIRE.
- DENOTES DEVICES EXTERNAL TO PBOX.
- WIRE ALL GROUND CONNECTIONS PER DRAWING 804704.
- THIS IS A GENERAL SCHEMATIC. NOT ALL DEVICES MAY BE PRESENT. SEE ORDER FOR NUMBER OF HOSES, HEADS, AUX, AND MOTORS.

ITEM	PART NUMBER	QTY	UOM	DESCRIPTION
PARTS LIST				
TOLERANCES (UNLESS OTHERWISE SPECIFIED)				
DO NOT SCALE DRAWING		STATUS	DES	 TITLE: V6, M210, 400V, DH HEATER CIRCUITS SCALE: DRAWN BY: BFO DATE: 08.08.13 SHEET 4 OF SHEETS 18 DRAWING NO. 821070
COMPUTER DESCRIPTIONS (CHARACTERS)	NEXT ASSY	FOR MACHINING STANDARDS AND DIMENSIONS, SEE TRW/DYNATEC SPEC. A05030	SOURCE	

THIS DRAWING IS THE PROPERTY OF INVA/DYNATEC.
DO NOT REPRODUCE OR DISCLOSE TO
OTHERS WITHOUT EXPRESS WRITTEN
CONSENT OF INVA/DYNATEC.

REVISIONS				
REV.	BY	DATE	BY	APPROVED

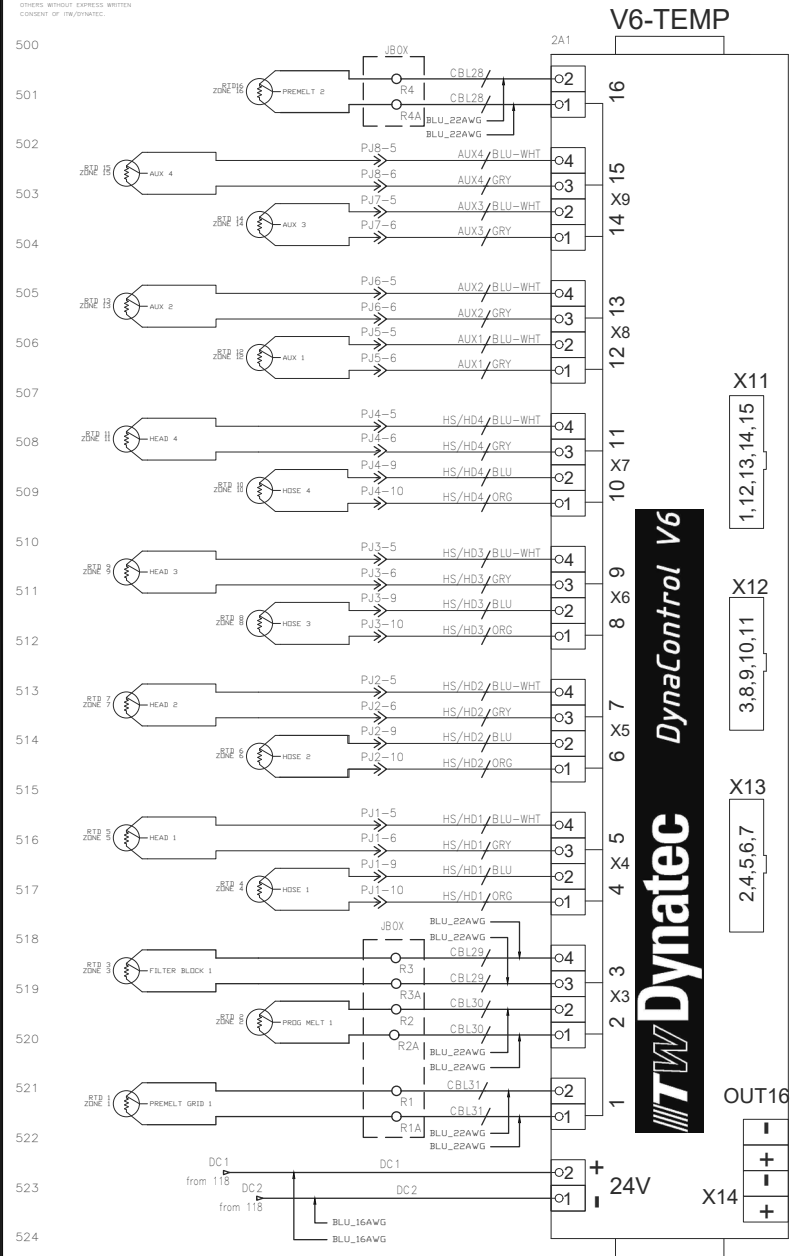

- ZONE**
- 16
 - 15
 - 14
 - 13
 - 12
 - 11
 - 10
 - 9
 - 8
 - 7
 - 6
 - 5
 - 4
 - 3
 - 2
 - 1

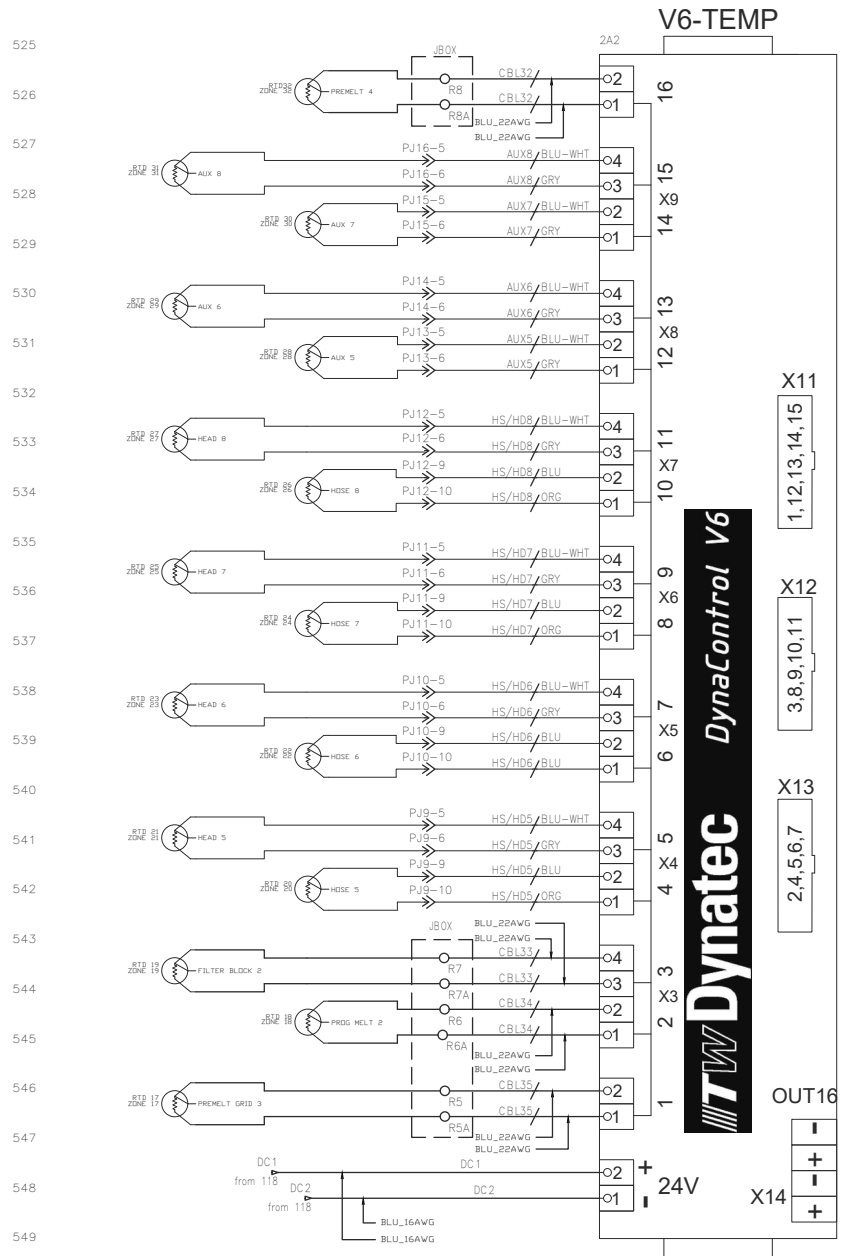

- ZONE**
- 32
 - 31
 - 30
 - 29
 - 28
 - 27
 - 26
 - 25
 - 24
 - 23
 - 22
 - 21
 - 20
 - 19
 - 18
 - 17

ITEM	PART NUMBER	QTY	UOM	PARTS LIST	DESCRIPTION

DO NOT SCALE DRAWING		TOLERANCES (UNLESS OTHERWISE SPECIFIED)			
COMPUTER DESCRIPTIONS (CHARACTERS)	NEXT ASSY	STATUS	REV		
FOR MACHINING STANDARDS AND DIMENSIONS, SEE INVA/DYNATEC SPEC. ADDRESS	DATE: 08.08.13	SHEET: 5	OF SHEETS: 18	DRAWN BY: B F Q	CHECKED BY: ---

THIS DRAWING IS THE PROPERTY OF ITW/DYNATEC.
DO NOT REPRODUCE OR DISCLOSE TO
OTHERS WITHOUT EXPRESS WRITTEN
CONSENT OF ITW/DYNATEC.

REVISIONS					
REV.	BY	DESCRIPTION	DATE	BY	APPROVED

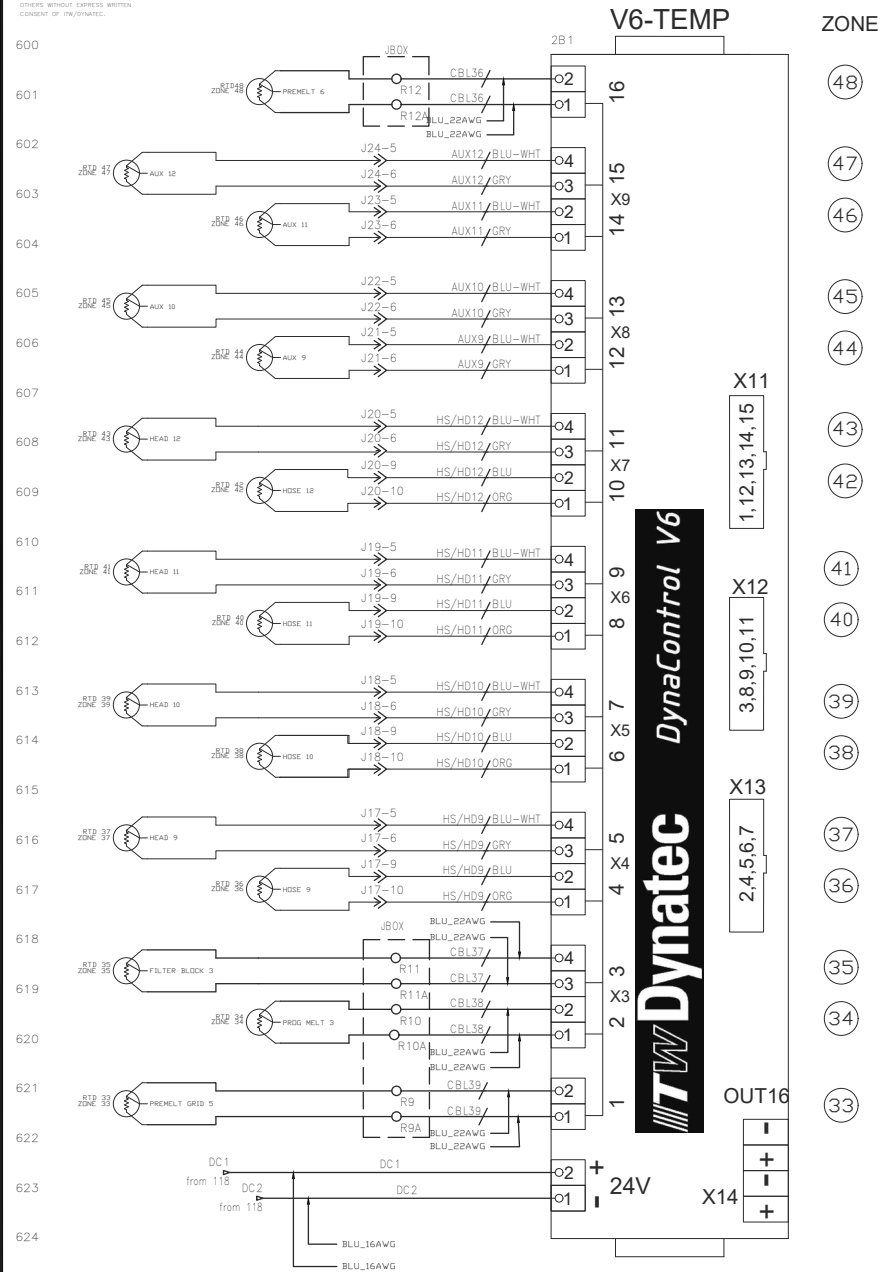

- (48)
- (47)
- (46)
- (45)
- (44)
- (43)
- (42)
- (41)
- (40)
- (39)
- (38)
- (37)
- (36)
- (35)
- (34)
- (33)

ITEM	PART NUMBER	QTY	UOM	DESCRIPTION										
PARTS LIST														
DO NOT SCALE DRAWING				<table border="1"> <tr> <td>STATUS</td> <td>DES</td> <td>DATE</td> <td>BY</td> <td>APPROVED</td> </tr> <tr> <td> </td> <td> </td> <td> </td> <td> </td> <td> </td> </tr> </table>	STATUS	DES	DATE	BY	APPROVED					
STATUS	DES	DATE	BY	APPROVED										
COMPUTER DESCRIPTIONS (CHARACTERS)		NEXT ASSY		<table border="1"> <tr> <td>SCALE:</td> <td>DRAWN BY:</td> <td>CHECKED BY:</td> <td>APP'D BY:</td> </tr> <tr> <td> </td> <td>BFG</td> <td>---</td> <td> </td> </tr> </table>	SCALE:	DRAWN BY:	CHECKED BY:	APP'D BY:		BFG	---			
SCALE:	DRAWN BY:	CHECKED BY:	APP'D BY:											
	BFG	---												
FOR MACHINING STANDARDS AND DIMENSIONS, SEE ITW/DYNATEC SPEC. ADDENDUM		SOURCE	REV.	<table border="1"> <tr> <td>DATE:</td> <td>SHEET</td> <td>OF SHEETS</td> <td>DRAWING NO.</td> </tr> <tr> <td>08.08.13</td> <td>6</td> <td>18</td> <td>821070</td> </tr> </table>	DATE:	SHEET	OF SHEETS	DRAWING NO.	08.08.13	6	18	821070		
DATE:	SHEET	OF SHEETS	DRAWING NO.											
08.08.13	6	18	821070											

THIS DRAWING IS THE PROPERTY OF INV/DYNATEC.
DO NOT REPRODUCE OR DISCLOSE TO
OTHERS WITHOUT EXPRESS WRITTEN
CONSENT OF INV/DYNATEC.

REVISIONS					
REV.	REV.	DESCRIPTION	DATE	BY	APPROVED

700
701
702
703
704
705
706
707
708
709
710
711
712
713
714
715
716
717
718
719
720
721
722
723
724

HOPPER A V6-BASE

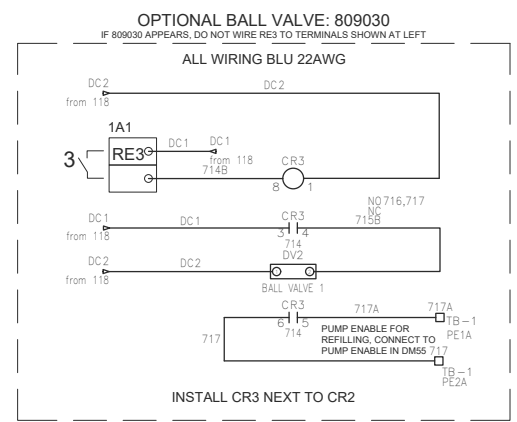
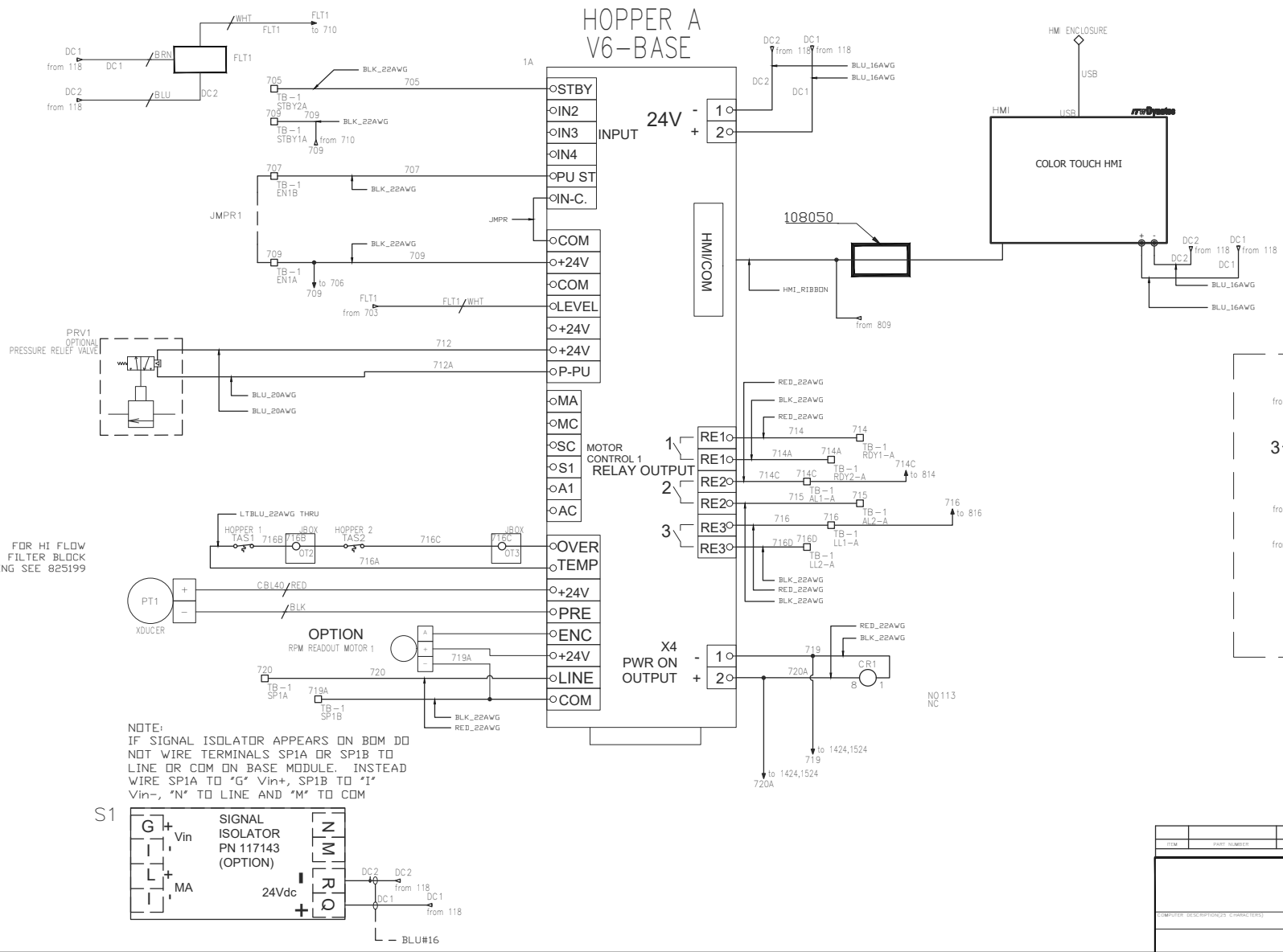

NOTE:
IF SIGNAL ISOLATOR APPEARS ON BOM DO
NOT WIRE TERMINALS SP1A OR SP1B TO
LINE OR COM ON BASE MODULE. INSTEAD
WIRE SP1A TO 'G' Vin+, SP1B TO 'I'
Vin-, 'N' TO LINE AND 'M' TO COM

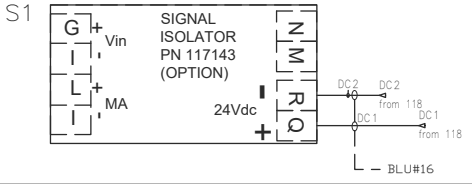

ITEM	PART NUMBER	QTY	UOM	DESCRIPTION
PARTS LIST				
DIFFERENCES (UNLESS OTHERWISE SPECIFIED)				
DO NOT SCALE DRAWING		STATUS	REV	TITLE: V6_M210_400V_DH BASE MODULE
FOR MACHINING STANDARDS AND DIMENSIONS SEE INV/DYNATEC SPEC. APPROB.		SCALE:	DRAWN BY: B FQ	CHECKED BY: ---
DATE: 08.08.13		SHEET 7	OF SHEETS 18	DRAWING NO. 821070

REVISIONS					
REV.	BY	DESCRIPTION	DATE	BY	APPROVED

THIS DRAWING IS THE PROPERTY OF INVA/DYNATEC.
DO NOT REPRODUCE OR DISCLOSE TO
OTHERS WITHOUT EXPRESS WRITTEN
CONSENT OF INVA/DYNATEC.

800
801
802
803
804
805
806
807
808
809
810
811
812
813
814
815
816
817
818
819
820
821
822
823
824

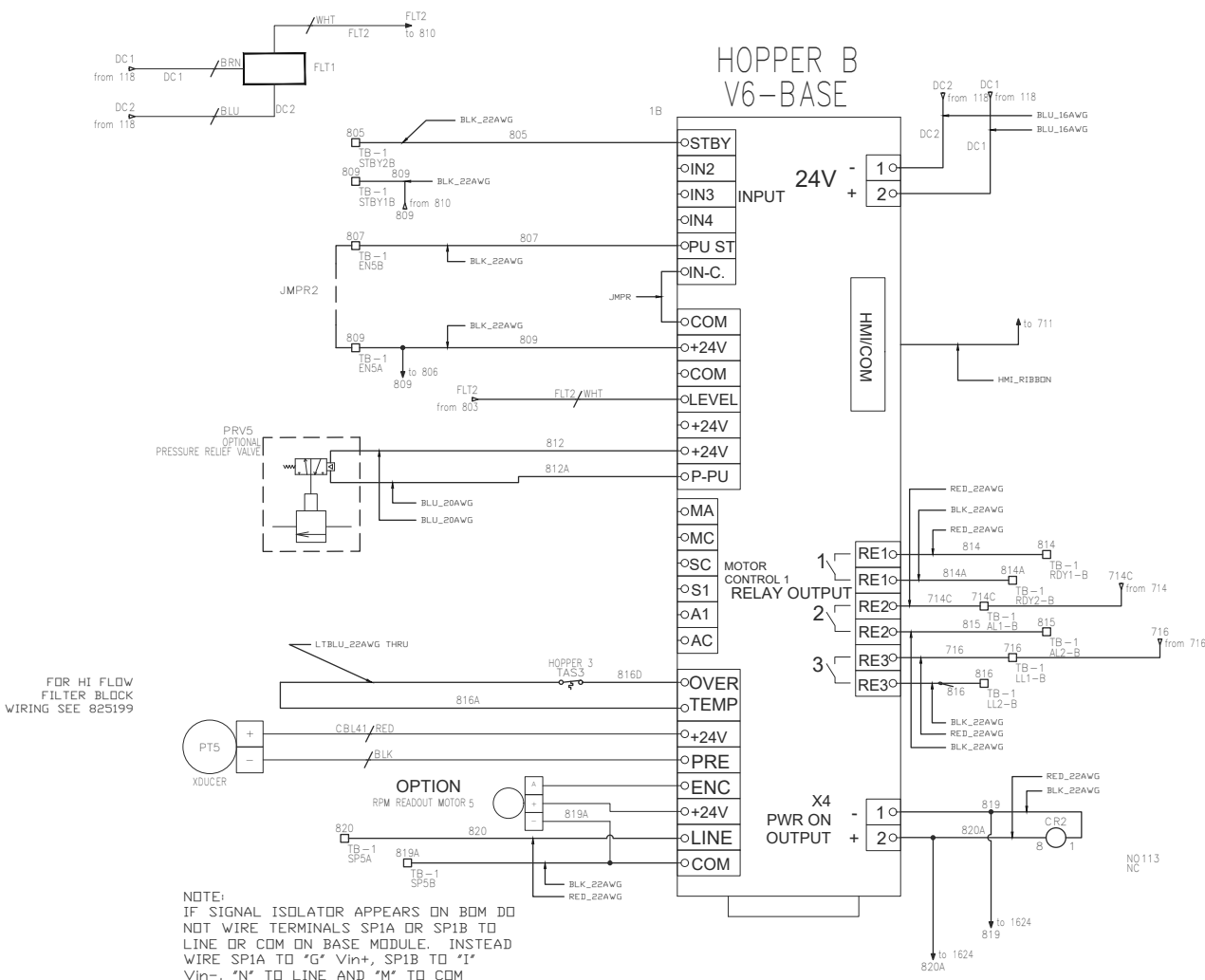

FOR HI FLOW
FILTER BLOCK
WIRING SEE 825199

NOTE:
IF SIGNAL ISOLATOR APPEARS ON BOM DO
NOT WIRE TERMINALS SP1A OR SP1B TO
LINE OR COM ON BASE MODULE. INSTEAD
WIRE SP1A TO 'G' Vin+, SP1B TO 'I'
Vin-, 'N' TO LINE AND 'M' TO COM

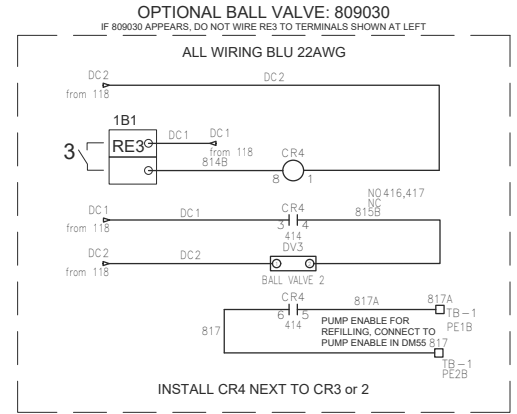
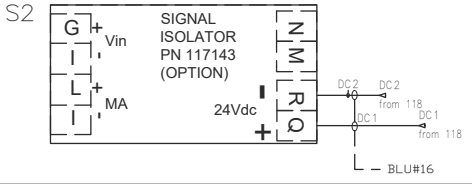

ITEM	PART NUMBER	QTY	UOM	DESCRIPTION

DO NOT SCALE DRAWING		TOLERANCES (UNLESS OTHERWISE SPECIFIED)		TITLE: V6, M210, 400V, DH BASE MODULE	
DATE	SCALE	STATUS	REV	DRAWN BY:	CHECKED BY:
08.08.13	B FQ	T			

FOR MACHINING STANDARDS AND DIMENSIONS, SEE INVA/DYNATEC SPEC. APPROB.	DATE	SHEET	OF SHEETS	DRAWING NO.
	08.08.13	8	18	821070

THIS DRAWING IS THE PROPERTY OF ITW/DYNATEC.
DO NOT REPRODUCE OR DISCLOSE TO
OTHERS WITHOUT EXPRESS WRITTEN
CONSENT OF ITW/DYNATEC.

REVISIONS					
REV.	BY	DESCRIPTION	DATE	BY	APPROVED

900

901

902

903

904

905

906

907

908

909

910

911

912

913

914

915

916

917

918

919

920

921

922

923

924

MOTOR CONTROL MODULE

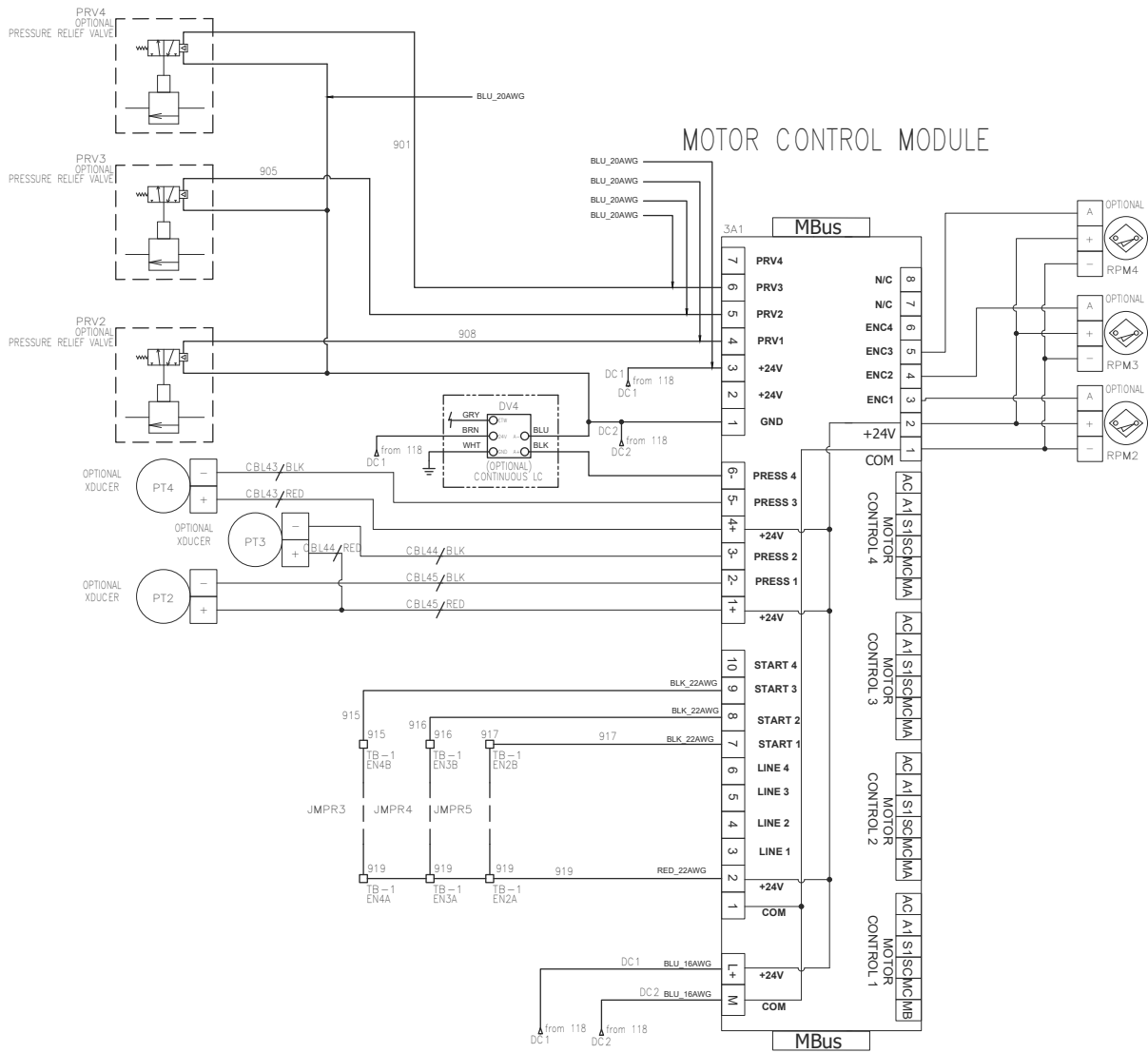

GENERAL NOTES:

- ALL PBOX WIRING LOWTEMP THHN 90°C WIRE.
- ALL EXTERNAL WIRING HITEMP TFE 260°C OR EQUIV.
- DENOTES TERMINAL IN PBOX
- DENOTES TERMINAL IN JBOX
- APPLY WIRE NUMBERS TO BOTH ENDS OF WIRE.
- DENOTES DEVICES EXTERNAL TO PBOX.
- - - - - DENOTES WIRING TO BE DONE BY OTHER/NOT INCLUDED.
- WIRE ALL GROUND CONNECTIONS PER DRAWING 804704
- THIS IS A GENERAL SCHEMATIC. NOT ALL DEVICES MAY BE PRESENT. SEE ORDER FOR NUMBER OF HOSES, HEADS, AUX. AND MOTORS.

ITEM	PART NUMBER	QTY	UOM	DESCRIPTION																														
PARTS LIST																																		
<table border="1"> <tr> <td colspan="2">DO NOT SCALE DRAWING</td> <td colspan="2">TOLERANCES (UNLESS OTHERWISE SPECIFIED)</td> <td colspan="2"> </td> </tr> <tr> <td colspan="2">COMPUTER DESCRIPTIONS (CHARACTERS)</td> <td colspan="2">NEXT ASSY</td> <td colspan="2"> TITLE: V6, M210, 400V, DH PRESSURE INPUTS </td> </tr> <tr> <td colspan="2">FOR MACHINING STANDARDS AND DIMENSIONS, SEE: A05050</td> <td colspan="2">SOURCE: T</td> <td colspan="2"> SCALE: BFO DATE: 08.08.13 </td> </tr> <tr> <td colspan="2"></td> <td colspan="2"></td> <td colspan="2"> DRAWN BY: BFO CHECKED BY: --- APPROV BY: --- </td> </tr> <tr> <td colspan="2"></td> <td colspan="2"></td> <td colspan="2"> SHEET: 9 OF SHEETS: 18 DRAWING NO: 821070 </td> </tr> </table>					DO NOT SCALE DRAWING		TOLERANCES (UNLESS OTHERWISE SPECIFIED)				COMPUTER DESCRIPTIONS (CHARACTERS)		NEXT ASSY		TITLE: V6, M210, 400V, DH PRESSURE INPUTS		FOR MACHINING STANDARDS AND DIMENSIONS, SEE: A05050		SOURCE: T		SCALE: BFO DATE: 08.08.13						DRAWN BY: BFO CHECKED BY: --- APPROV BY: ---						SHEET: 9 OF SHEETS: 18 DRAWING NO: 821070	
DO NOT SCALE DRAWING		TOLERANCES (UNLESS OTHERWISE SPECIFIED)																																
COMPUTER DESCRIPTIONS (CHARACTERS)		NEXT ASSY		TITLE: V6, M210, 400V, DH PRESSURE INPUTS																														
FOR MACHINING STANDARDS AND DIMENSIONS, SEE: A05050		SOURCE: T		SCALE: BFO DATE: 08.08.13																														
				DRAWN BY: BFO CHECKED BY: --- APPROV BY: ---																														
				SHEET: 9 OF SHEETS: 18 DRAWING NO: 821070																														

REVISIONS			
REV.	BY	DESCRIPTION	DATE

THIS DRAWING IS THE PROPERTY OF INVA/DYNATEC.
DO NOT REPRODUCE OR DISCLOSE TO
OTHERS WITHOUT EXPRESS WRITTEN
CONSENT OF INVA/DYNATEC.

1000
1001
1002
1003
1004
1005
1006
1007
1008
1009
1010
1011
1012
1013
1014
1015
1016
1017
1018
1019
1020
1021
1022
1023
1024

MOTOR CONTROL MODULE

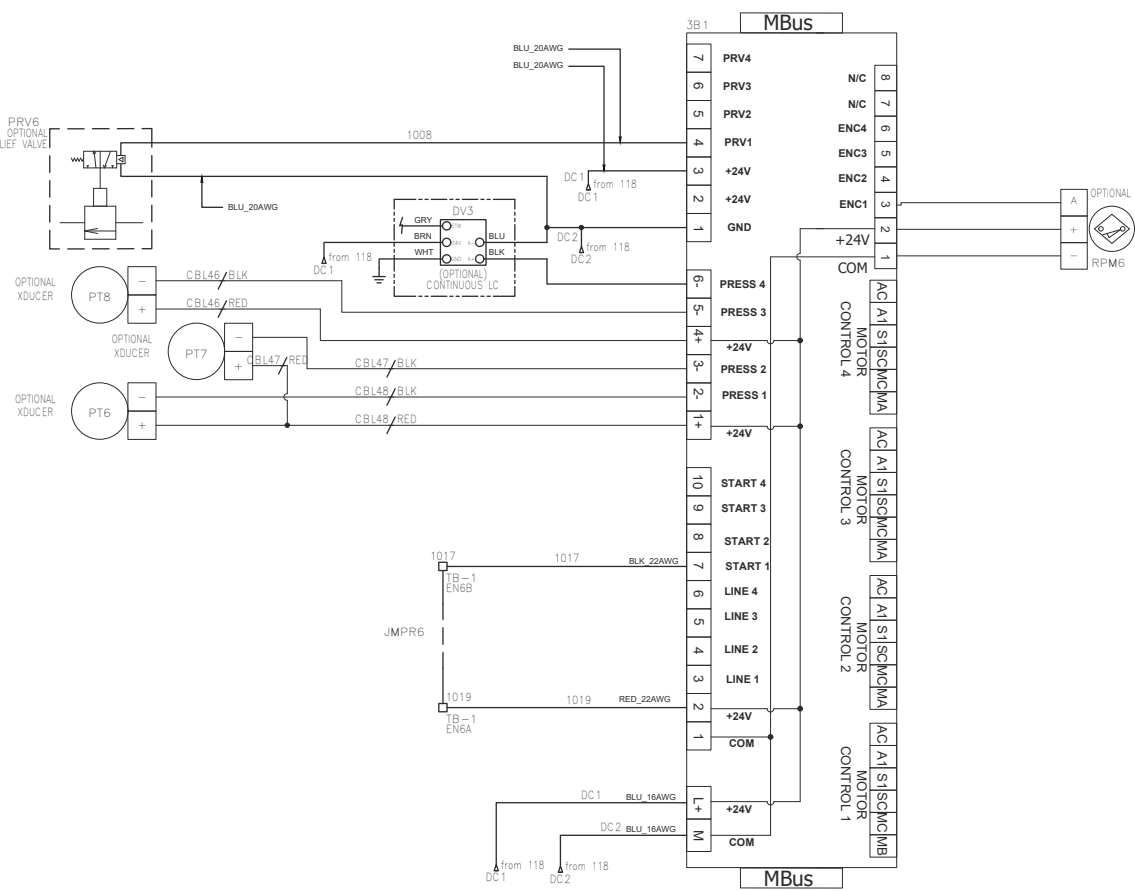

- GENERAL NOTES:
- ALL PBOX WIRING LOWTEMP THHN 90°C WIRE.
 - ALL EXTERNAL WIRING HITEMP TFE 260°C OR EQUIV.
 - DENOTES TERMINAL IN PBOX
 - DENOTES TERMINAL IN JBOX
 - APPLY WIRE NUMBERS TO BOTH ENDS OF WIRE.
 - DENOTES DEVICES EXTERNAL TO PBOX.
 - DENOTES WIRING TO BE DONE BY OTHER/NOT INCLUDED.
 - WIRE ALL GROUND CONNECTIONS PER DRAWING 804704
 - THIS IS A GENERAL SCHEMATIC. NOT ALL DEVICES MAY BE PRESENT. SEE ORDER FOR NUMBER OF HOSES, HEADS, AUX. AND MOTORS.

ITEM	PART NUMBER	QTY	UOM	DESCRIPTION	TOLERANCES (UNLESS OTHERWISE SPECIFIED)	STATUS	REV	DYNATEC TITLE: V6, M210, 400V, DH PRESSURE INPUTS		
DO NOT SCALE DRAWING						SCALE:	DRAWN BY: BFG		CHECKED BY: ---	APP'D BY: ---
FOR MACHINING STANDARDS AND DIMENSIONS, SEE DWG/CHARTER SPEC. APPROX						SOURCE: T	DATE: 08.08.13	SHEET: 10	OF SHEETS: 18	DRAWING NO.: 821070

REVISIONS					
REV.	REV.	DESCRIPTION	DATE	BY	APPROVED

THIS DRAWING IS THE PROPERTY OF IAW/DYNATEC.
DO NOT REPRODUCE OR DISCLOSE TO
OTHERS WITHOUT EXPRESS WRITTEN
CONSENT OF IAW/DYNATEC.

1100
1101
1102
1103
1104
1105
1106
1107
1108
1109
1110
1111
1112
1113
1114
1115
1116
1117
1118
1119
1120
1121
1122
1123
1124

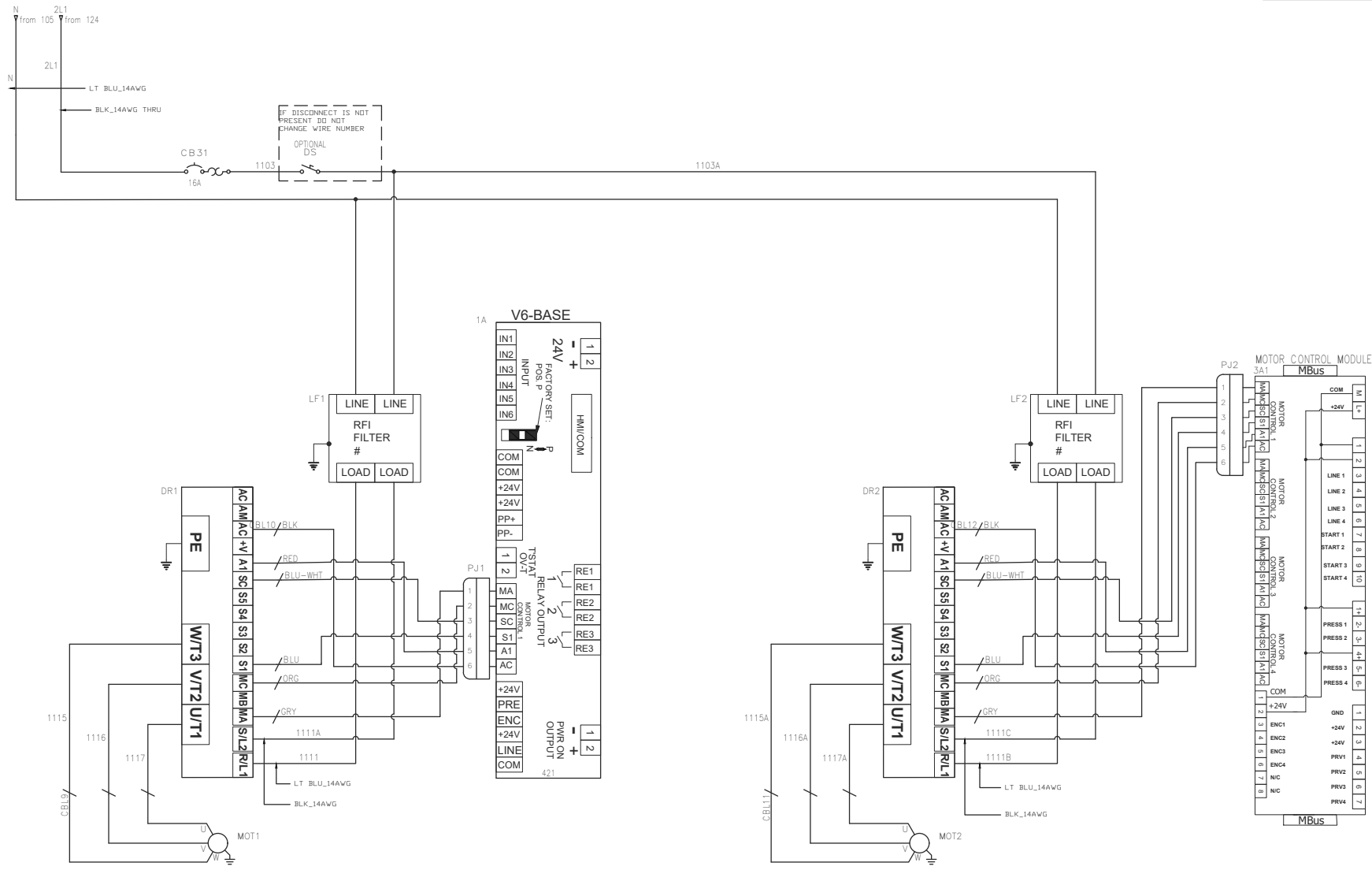

ITEM	PART NUMBER	QTY	U/M	PARTS LIST	DESCRIPTION

DO NOT SCALE DRAWING		REFERENCES (UNLESS OTHERWISE SPECIFIED)		 <small>MEMPHISVILLE, TN</small>	
NEXT ASSY		STATUS			
FOR MACHINING STANDARDS AND DIMENSIONS, SEE IAW/DYNATEC SPEC. APPROV.		SCALE:	DATE:	DRAWN BY:	CHECKED BY:
		T	08.08.13	BFG	---
				SHEET 11	OF SHEETS 18
		DRAWING NO. 821070			

REVISIONS					
REV.	BY	DESCRIPTION	DATE	BY	APPROVED

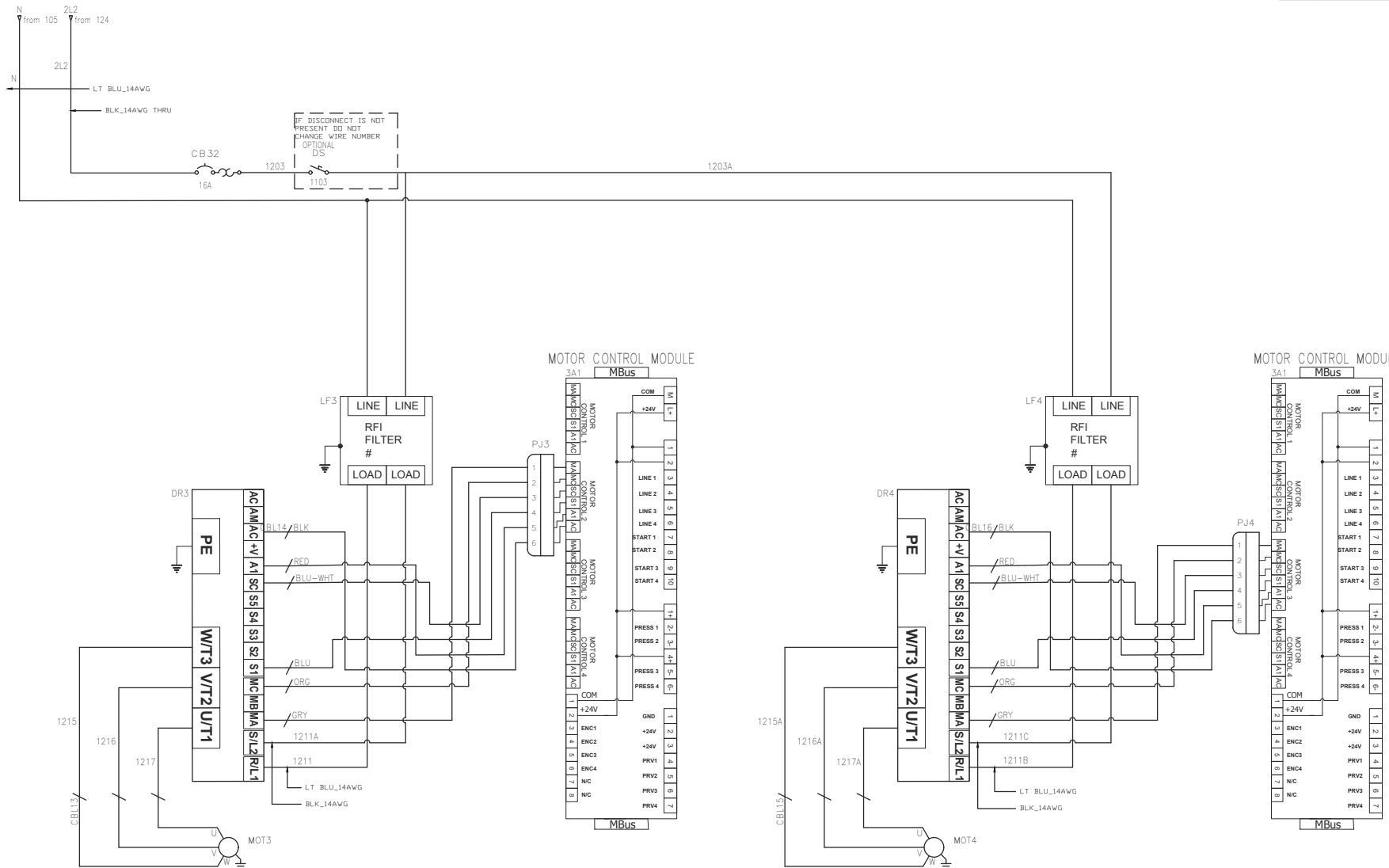

THIS DRAWING IS THE PROPERTY OF IAW/DYNATEC.
DO NOT REPRODUCE OR DISCLOSE TO
OTHERS WITHOUT EXPRESS WRITTEN
CONSENT OF IAW/DYNATEC.

1200
1201
1202
1203
1204
1205
1206
1207
1208
1209
1210
1211
1212
1213
1214
1215
1216
1217
1218
1219
1220
1221
1222
1223
1224

ITEM	PART NUMBER	QTY	U/M	DESCRIPTION

DO NOT SCALE DRAWING		TOLERANCES (UNLESS OTHERWISE SPECIFIED)		 TITLE: V6, M210, 400V, DH DRIVE INPUT	
COMPUTER DESCRIPTIONS (CHARACTERS)	NEXT ASSY	STATUS	REV		
FOR MACHINING STANDARDS AND DIMENSIONS, SEE IAW/DYNATEC SPEC. APPROV.	DATE	SOURCE	REV.	DRAWN BY: B F Q	CHECKED BY: ---
	08.08.13			SHEET 12 OF SHEETS 18	DRAWING NO. 821070

THIS DRAWING IS THE PROPERTY OF INW/DYNATEC.
DO NOT REPRODUCE OR DISCLOSE TO
OTHERS WITHOUT EXPRESS WRITTEN
CONSENT OF INW/DYNATEC.

REVISIONS					
REV.	BY	DESCRIPTION	DATE	BY	APPROVED

1300
1301
1302
1303
1304
1305
1306
1307
1308
1309
1310
1311
1312
1313
1314
1315
1316
1317
1318
1319
1320
1321
1322
1323
1324

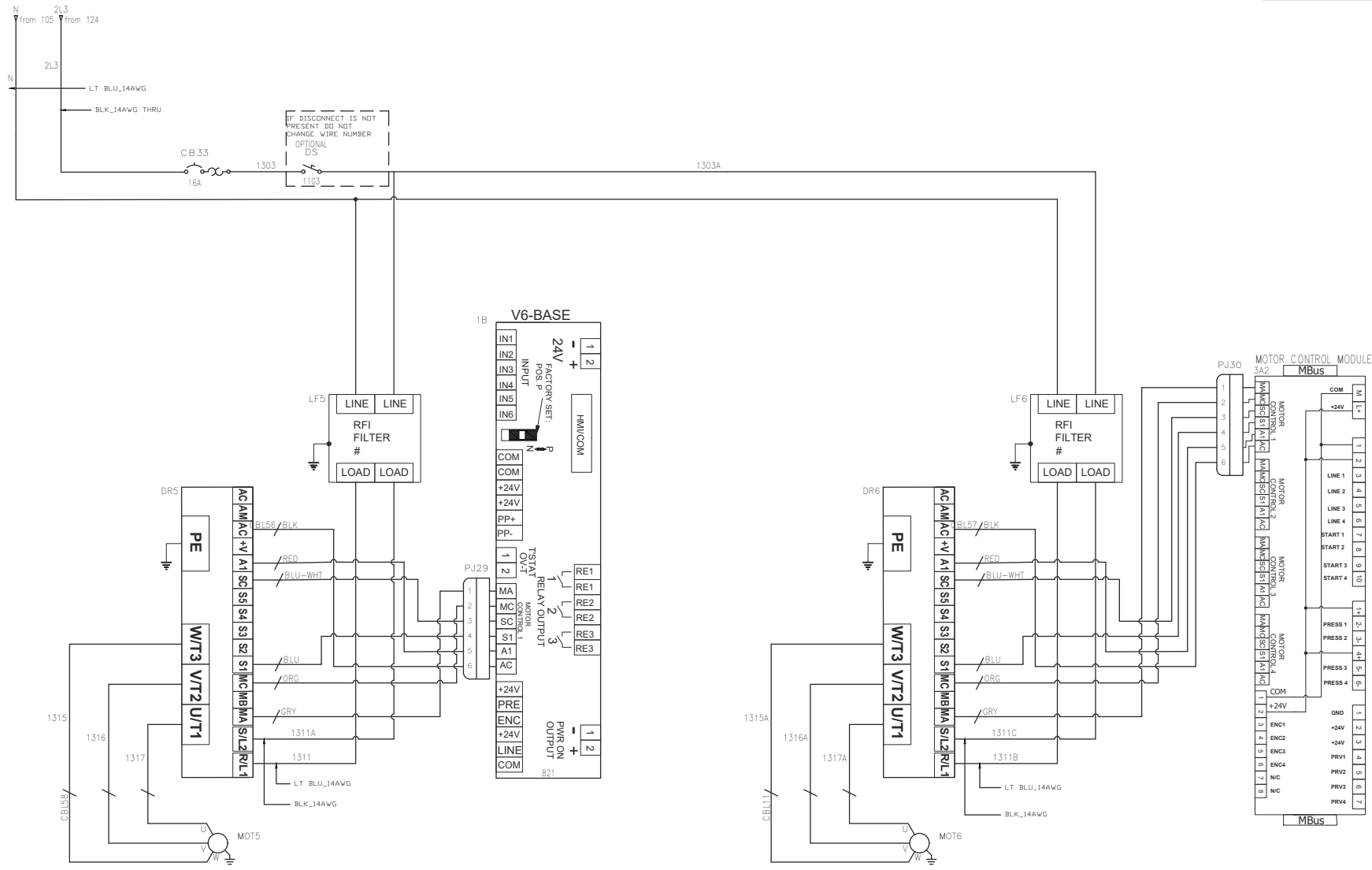

ITEM	PART NUMBER	QTY	U/M	PARTS LIST	DESCRIPTION

DO NOT SCALE DRAWING NEXT ASSY		STATUS DES	REFERENCE UNLESS OTHERWISE SPECIFIED	
COMPUTER DESCRIPTIONS (CHARACTERS) FOR MACHINING STANDARDS AND DIMENSIONS, SEE INW/DYNATEC SPEC. APPROX		SCALE T	DATE 08.08.13	TITLE: V6, M210, 400V, DH DRIVE INPUT DRAWN BY: B F Q CHECKED BY: --- APP'D BY: --- SHEET 13 OF SHEETS 18 DRAWING NO. 821070

THIS DRAWING IS THE PROPERTY OF TW/DYNATEC.
DO NOT REPRODUCE OR DISCLOSE TO
OTHERS WITHOUT EXPRESS WRITTEN
CONSENT OF TW/DYNATEC.

REV.	BY	DESCRIPTION	DATE	BY	APPROVED

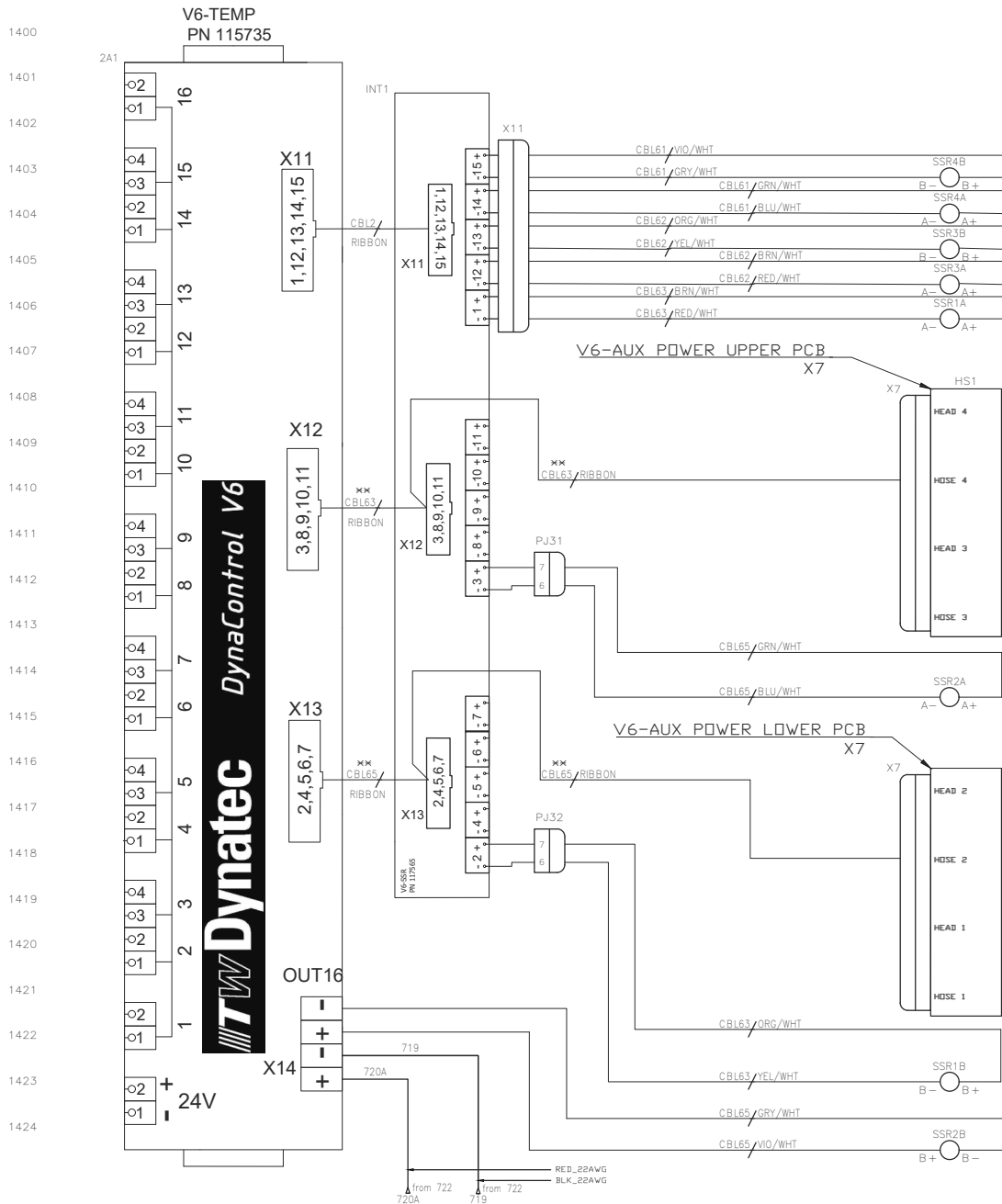

HEATING ZONE

****NOTE**

CONFIGURATION SHOWN IS FOR A SYSTEM WITH FOUR OR MORE HOSE/HEAD CONNECTIONS REQUIRED WHERE CBL63 AND CBL65 ARE DUAL CABLES (P/N 823321). FOR A TWO HOSE/HEAD SYSTEM, CBL63 IS A SINGLE CABLE (P/N 823319) CONNECTED BETWEEN X12 ON V6-TEMP AND X12 ON INT1.

ITEM	PART NUMBER	QTY	UOM	DESCRIPTION										
PARTS LIST														
<table border="1" style="width:100%"> <thead> <tr> <th colspan="2">TOLERANCES (UNLESS OTHERWISE SPECIFIED)</th> <th colspan="3"> </th> </tr> </thead> <tbody> <tr> <td> </td> <td> </td> <td> </td> <td> </td> <td> </td> </tr> </tbody> </table>					TOLERANCES (UNLESS OTHERWISE SPECIFIED)									
TOLERANCES (UNLESS OTHERWISE SPECIFIED)														
TW Dynatec														
TITLE: V6, M210, 400V, DH														
SSR OUTPUTS														
DO NOT SCALE DRAWING														
COMPUTER DESCRIPTIONS (CHARACTERS)		NEXT Assy												
FOR MACHINING STANDARDS AND DIMENSIONS, SEE TW/DYNATEC SPEC. APPEND														

SCALE:	DRAWN BY:	CHECKED BY:	APP'D BY:
	BFG	---	---
DATE:	SHEET	OF SHEETS	DRAWING NO.
08.08.13	14	18	821070

THIS DRAWING IS THE PROPERTY OF ITW/DYNATEC.
DO NOT REPRODUCE OR DISCLOSE TO
OTHERS WITHOUT EXPRESS WRITTEN
CONSENT OF ITW/DYNATEC.

REV.	BY	DESCRIPTION	DATE	BY	APPROVED

V6-TEMP
PN 115735

1500
1501
1502
1503
1504
1505
1506
1507
1508
1509
1510
1511
1512
1513
1514
1515
1516
1517
1518
1519
1520
1521
1522
1523
1524

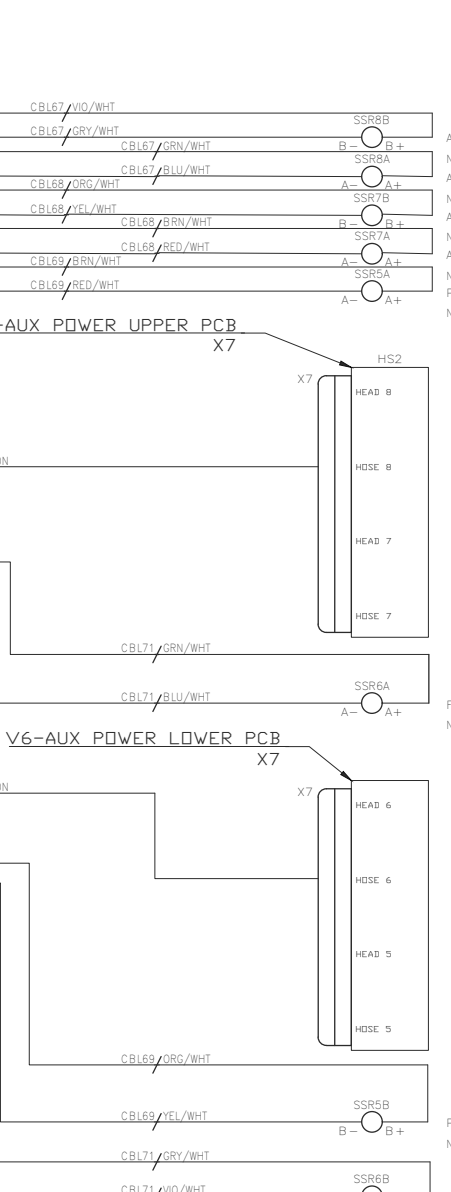
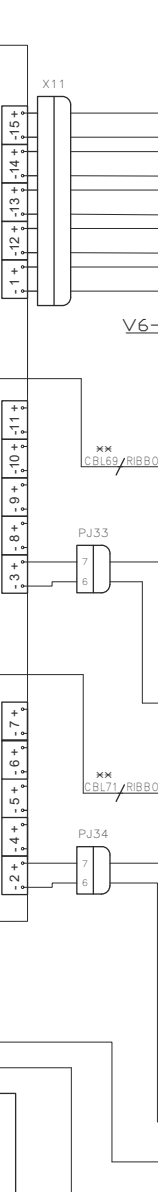
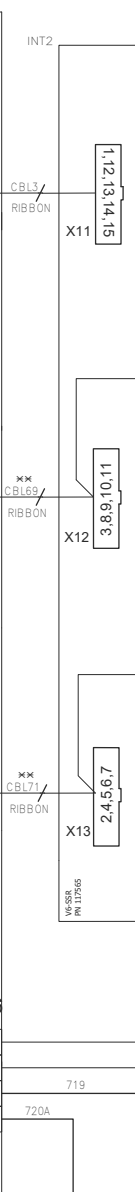
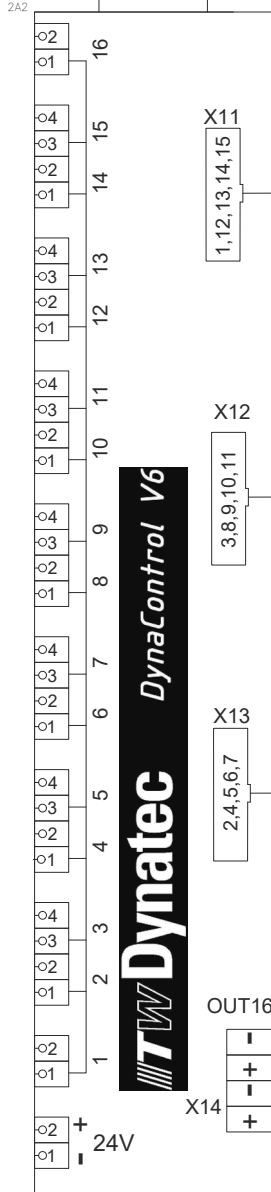

HEATING ZONE



**NOTE

CONFIGURATION SHOWN IS FOR IS FOR A SYSTEM WITH EIGHT OR MORE HOSE/HEAD CONNECTIONS REQUIRED WHERE CBL69 AND CBL71 ARE DUAL CABLES (P/N 823321). FOR A SYSTEM WITH LESS THAN EIGHT HOSE/HEAD CONNECTIONS, A SINGLE CABLE (P/N 823319) IS CONNECTED BETWEEN CONNECTOR X12/X13 ON V6-TEMP AND X12/X13 ON INT2 WHERE A PCB HOSE/HEAD CONNECTION IS NOT REQUIRED.

ITEM	PART NUMBER	QTY	UOM	DESCRIPTION

DO NOT SCALE DRAWING NEXT ASSY		TOLERANCES UNLESS OTHERWISE SPECIFIED		WILSONVILLE, TN	
TITLE: V6, M210, 400V, DH SSR OUTPUTS	SCALE: B F Q	DRAWN BY: B F Q	CHECKED BY: ---	APP'D BY:	
DATE: 08.08.13	SHEET 15	OF SHEETS 18	DRAWING NO. 821070	FOR MACHINING STANDARDS AND DIMEN'S, SEE ITW/DYNATEC SPEC. A05289	

THIS DRAWING IS THE PROPERTY OF ITW/DYNATEC.
DO NOT REPRODUCE OR DISCLOSE TO
OTHERS WITHOUT EXPRESS WRITTEN
CONSENT OF ITW/DYNATEC.

REVISIONS					
REV.	BY	DESCRIPTION	DATE	BY	APPROVED

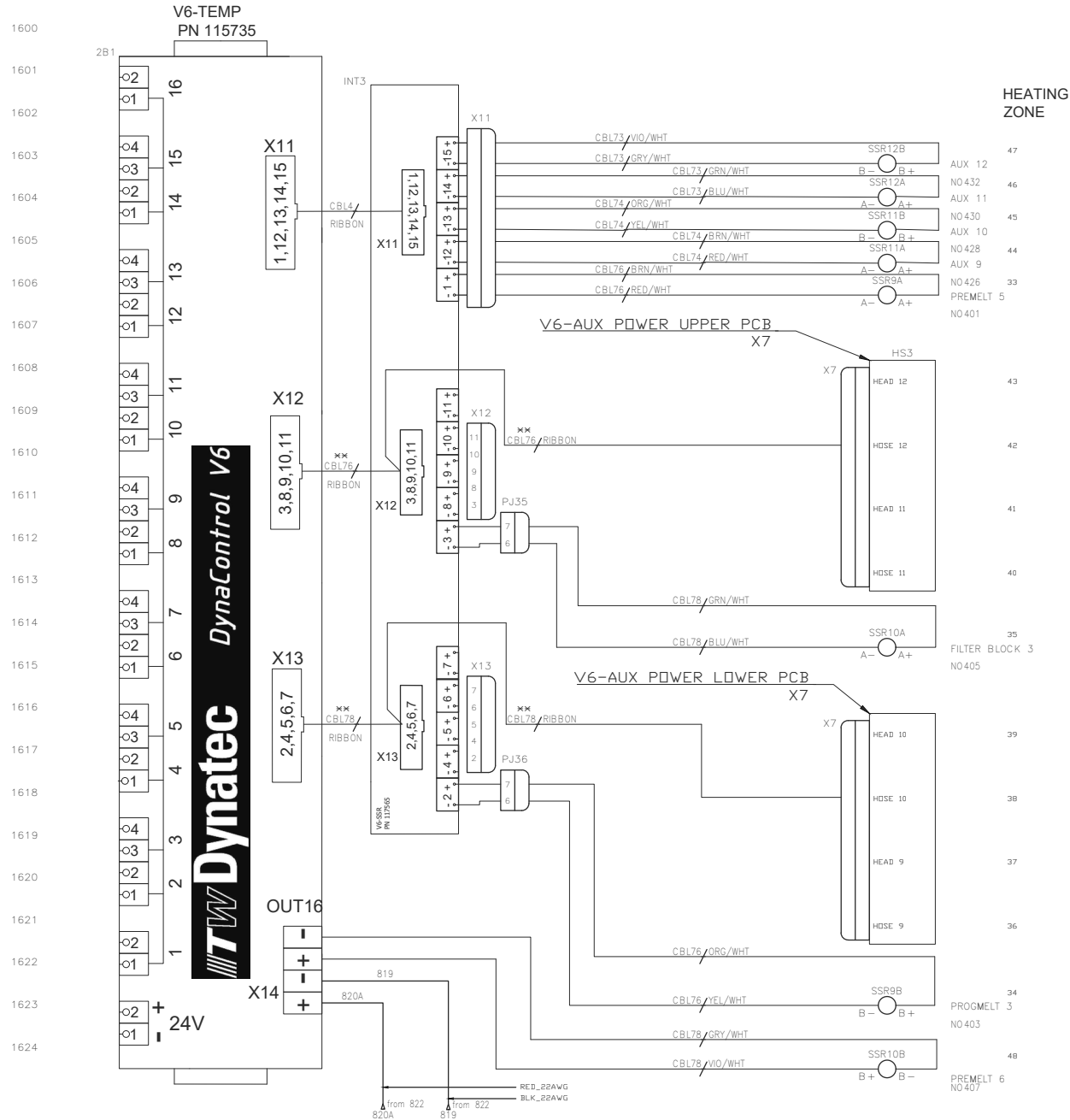

HEATING ZONE

****NOTE**

CONFIGURATION SHOWN IS FOR A SYSTEM WITH TWELVE HOSE/HEAD CONNECTIONS REQUIRED WHERE CBL76 AND CBL78 ARE DUAL CABLES (P/N 823321). FOR A SYSTEM WITH LESS THAN TWELVE HOSE/HEAD CONNECTIONS, A SINGLE CABLE (P/N 823319) IS CONNECTED BETWEEN CONNECTOR X12/X13 ON V6-TEMP AND X12/X13 ON INT3 WHERE A PCB HOSE/HEAD CONNECTION IS NOT REQUIRED.

ITEM	PART NUMBER	QTY	UOM	PARTS LIST	DESCRIPTION

DO NOT SCALE DRAWING		TOLERANCES (UNLESS OTHERWISE SPECIFIED)			
COMPUTER DESCRIPTIONS (CHARACTERS)	NEXT ASSY	STATUS	DES		
FOR MACHINING STANDARDS AND DIMENSIONS, SEE ITW/DYNATEC SPEC. APPROX.		SCALE:	DRAWN BY:	CHECKED BY:	APP'D BY:
		T	BFO	---	---
DATE:	08.08.13	SHEET:	16	OF SHEETS:	18
DRAWING NO.:	821070				

THIS DRAWING IS THE PROPERTY OF INVA/DYNATEC.
DO NOT REPRODUCE OR DISCLOSE TO
OTHERS WITHOUT EXPRESS WRITTEN
CONSENT OF INVA/DYNATEC.

REVISIONS				
REV.	BY	DESCRIPTION	DATE	APPROVED

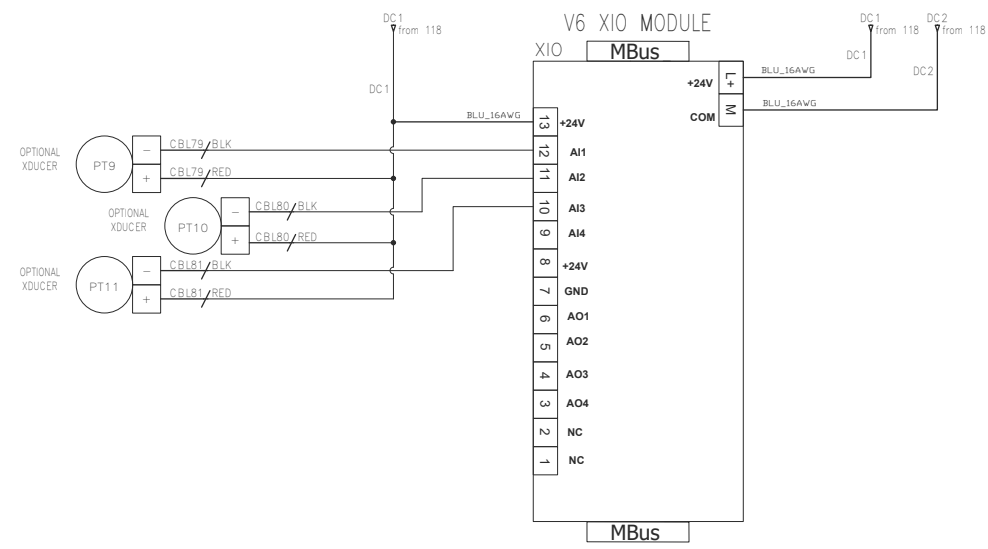
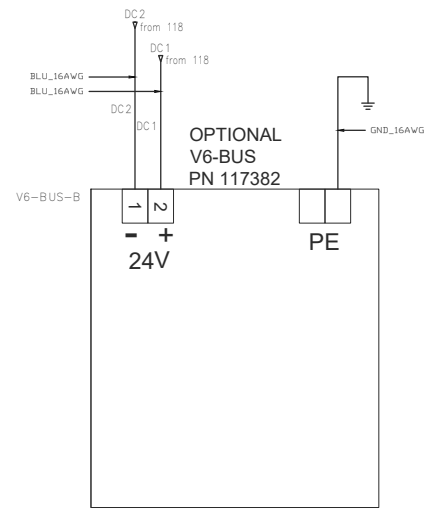
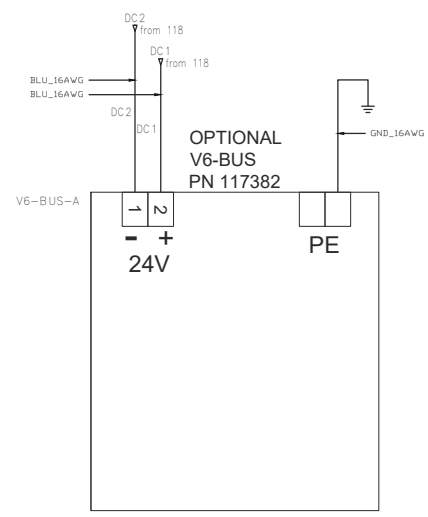

ITEM	PART NUMBER	QTY	UOM	DESCRIPTION																								
PARTS LIST																												
DO NOT SCALE DRAWING				<table border="1"> <tr> <td>TOLERANCES (UNLESS OTHERWISE SPECIFIED)</td> <td>U/M</td> <td>STATUS</td> <td>ISS</td> </tr> <tr> <td> </td> <td> </td> <td> </td> <td> </td> </tr> </table>	TOLERANCES (UNLESS OTHERWISE SPECIFIED)	U/M	STATUS	ISS																				
TOLERANCES (UNLESS OTHERWISE SPECIFIED)	U/M	STATUS	ISS																									
COMPUTER DESCRIPTIONS (CHARACTERS)		NEXT ASSY		<table border="1"> <tr> <td colspan="2">TITLE: V6, M210, 400V, DH</td> <td colspan="2">DYNATEC</td> </tr> <tr> <td colspan="2">OPTIONS</td> <td colspan="2">MEMPHIS, TN</td> </tr> <tr> <td>SCALE:</td> <td>DRAWN BY:</td> <td>CHECKED BY:</td> <td>APP'D BY:</td> </tr> <tr> <td> </td> <td> </td> <td> </td> <td> </td> </tr> <tr> <td>DATE:</td> <td>SHEET</td> <td>OF SHEETS</td> <td>DRAWING NO.</td> </tr> <tr> <td>08.08.13</td> <td>17</td> <td>18</td> <td>821070</td> </tr> </table>	TITLE: V6, M210, 400V, DH		DYNATEC		OPTIONS		MEMPHIS, TN		SCALE:	DRAWN BY:	CHECKED BY:	APP'D BY:					DATE:	SHEET	OF SHEETS	DRAWING NO.	08.08.13	17	18	821070
TITLE: V6, M210, 400V, DH		DYNATEC																										
OPTIONS		MEMPHIS, TN																										
SCALE:	DRAWN BY:	CHECKED BY:	APP'D BY:																									
DATE:	SHEET	OF SHEETS	DRAWING NO.																									
08.08.13	17	18	821070																									
FOR MACHINING STANDARDS AND DIMENSIONS, SEE INV/DYNATEC SPEC. ADDRESS		SOURCE:	REV.:																									
		T																										

THIS DRAWING IS THE PROPERTY OF RW/DYNATEC.
DO NOT REPRODUCE OR DISCLOSE TO
OTHERS WITHOUT EXPRESS WRITTEN
CONSENT OF RW/DYNATEC.

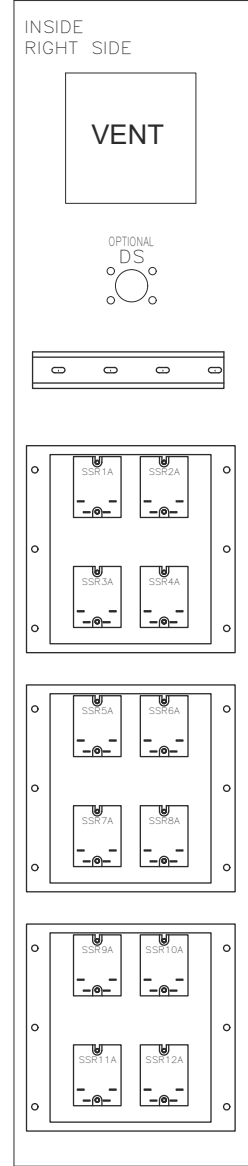
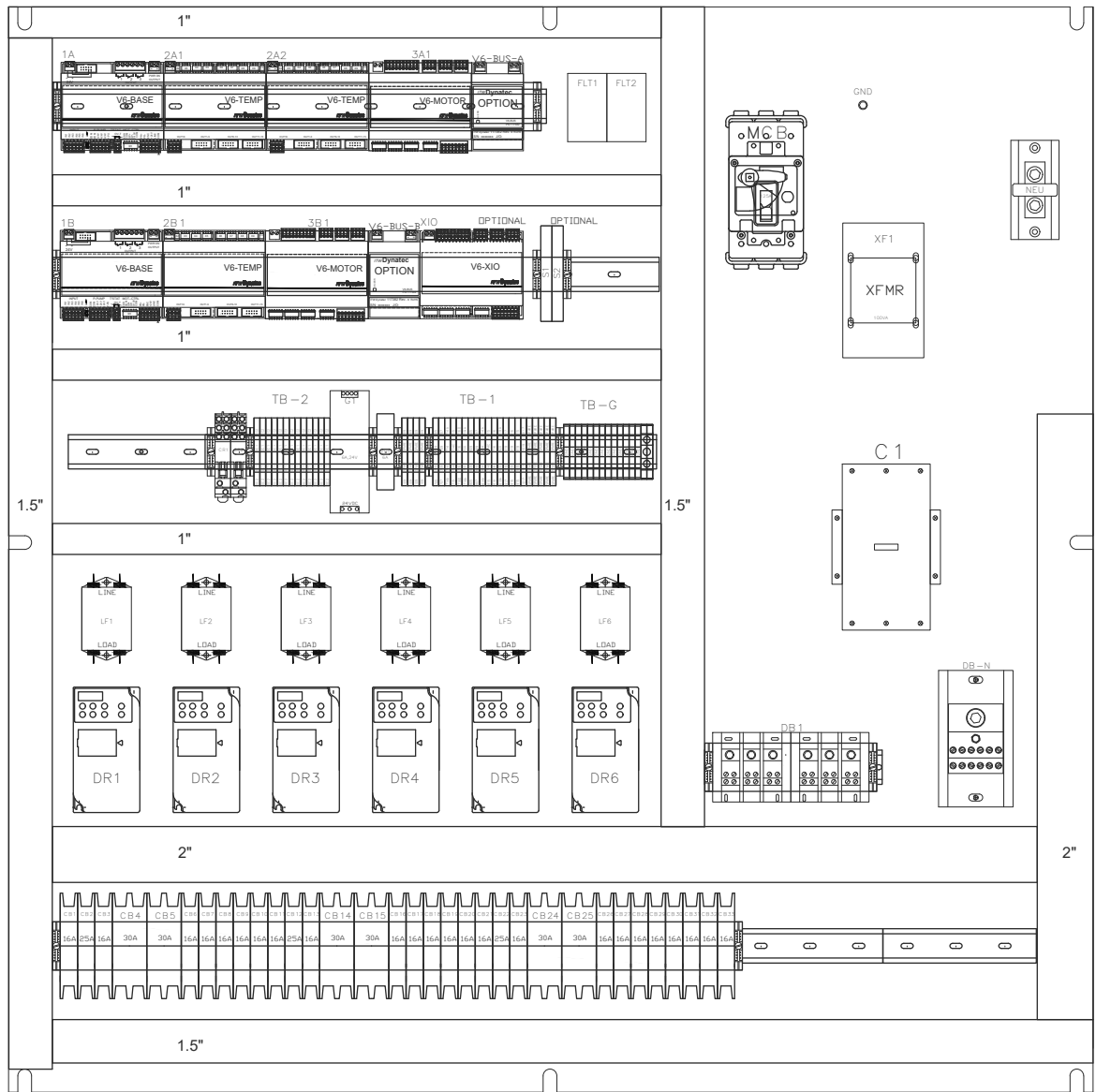
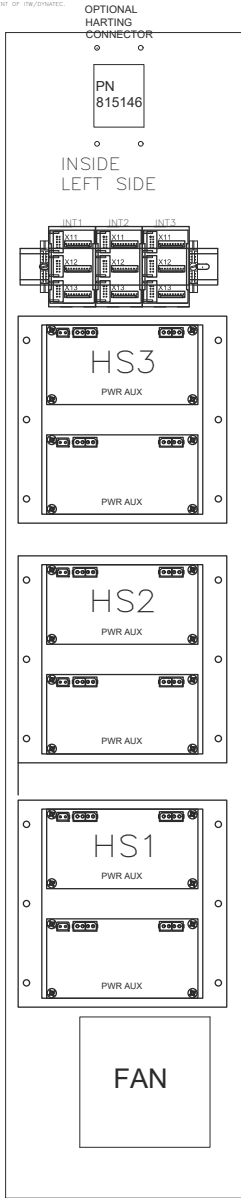

REVISIONS				
REV.	BY	DESCRIPTION	DATE	APPROVED
TB-1				
LOWER TERMINAL		UPPER TERMINAL		
WIRE NO.	DESC. (REF.)	WIRE NO.	DESC. (REF.)	
109	240VAC	SPARE	SPARE	
109	240VAC	SPARE	SPARE	
109	240VAC	SPARE	SPARE	
705	STBY2A	709	STBY1A	
707	EN1B	709	EN1A	
714A	REL2-A	714	REL1-A	
715	ALL2-A	714	ALL1-A	
716B	LL2-A	716	LL1-A	
719A	SP1B	709	SP1A	
805	STBY2B	809	STBY1B	
807	EN2B	809	EN2A	
804A	REL2-B	814	REL1-B	
815	ALL2-B	714	ALL1-B	
818	LL2-B	716	LL1-B	
819A	SP2B	809	SP2A	
917	EN2B	919	EN2A	
918	EN4B	919	EN4A	
915	EN4B	919	EN4A	
1017	EN6B	1019	EN6A	
SPARE	SPARE	SPARE	SPARE	
SPARE	SPARE	SPARE	SPARE	
SPARE	SPARE	SPARE	SPARE	
SPARE	SPARE	SPARE	SPARE	
TB-2				
LOWER TERMINAL		UPPER TERMINAL		
WIRE NO.	DESC. (REF.)	WIRE NO.	DESC. (REF.)	
001	0VAC	001	PS24VAC	

TAGS	PART NUMBER	DESCRIPTION
1A.1B	115734	V6-BASE MODULE
2A1,2A2,2B1	115735	V6-BUS EXPANSION
1A1,2B1	115735	V6-TEMPERATURE MODULE
01	115735	V6-MOTOR MODULE
	821748	MAIN CONTACTOR
	822087	IP20 FUR CONTACTOR
	822087	DISSIPATION FOR CONT
0.1,3-9,11-17,19-27	104207	CB-150A,2 POLE
0.2,10,18	825249	CB-25A,2 POLE
0.2	825249	CONTACTOR RELAY
DR1	821749	DISTRIBUTION BLOCK
DR1-6	815222	VFD,HP
0.2	822096	2 POLE FUSE BLOCK,PCCL
0.2	822096	FUSE,AMPS,1,PCCL
FUZ-7	812413	J POLE FUSE BLOCK,PCCL
	822096	FUSE,AMPS,1,PCCL
01	119186	POWER SUPPLY,6AMP,24V
GND	825250	GROUND LUG
0.1	115735	V6-PM
HS1-3	823306	V6-POWER BOARD
0.1-6	117856	LINE-BLOWER
MC1	821938	CB-150A,3 POLE MAIN CIRCUIT BREAKER
	821940	MCB OPERATOR
	821942	MCB IP20 SHIELD
SSR1-12	114282	DUAL CHANNEL SSR
VB-1,2	110251	DUAL TERMINAL
V6-BUS	117282	V6-COMMUNICATION MODULE
0.1	110250	11-101 TRANSFORMER
	823403	IP20 SHIELD FOR TRANSFORMER
X10	117648	V6-X10 MIDDLE

NOTE:
IF DRIVE DISCONNECT IS INCLUDED MOUNT ON
RIGHT WALL BELOW EXHAUST VENT

ITEM	PART NUMBER	QTY	UOM	DESCRIPTION
PARTS LIST				
DO NOT SCALE DRAWING				
COMPUTER DESCRIPTIONS (CHARACTERS)	NEXT ASSY	STATUS	ISS	SCALE
FOR MACHINING STANDARDS AND DIMENSIONS, SEE RW/DYNATEC SPEC. APPENDIX		T		DATE: 08.08.13
TOLERANCES (UNLESS OTHERWISE SPECIFIED)		TITLE: V6_M210_400V_DH LAYOUT		DATE: 08.08.13
SCALE: B FQ		DRAWN BY: B FQ		CHECKED BY: APPD BY:
SHEET 18		OF SHEETS 18		DRAWING NO. 821070



11.10 Schematics V6 M-series Trigger Wiring, PN 824665

THIS DRAWING IS THE PROPERTY OF ITW/DYNATEC.
DO NOT REPRODUCE OR DISCLOSE TO
OTHERS WITHOUT EXPRESS WRITTEN
CONSENT OF ITW/DYNATEC.

REVISIONS					
REL.	REV.	DESCRIPTION	DATE	BY	APPROVED
335499	A	FIRST RELEASE	06.18.16	BFQ	

WIRE AS HARNESSES AS SHOWN TO RIGHT PER LIST BELOW

M35

UP TO 2 OF 820421 CONNECTED TO MOTOR ENABLES 1,2

M70/140

UP TO 4 OF 820421 CONNECTED TO MOTOR ENABLES 1,2,3,4

M210

UP TO 6 OF 820421 CONNECTED TO MOTOR ENABLES 1,2,3,4,5,6

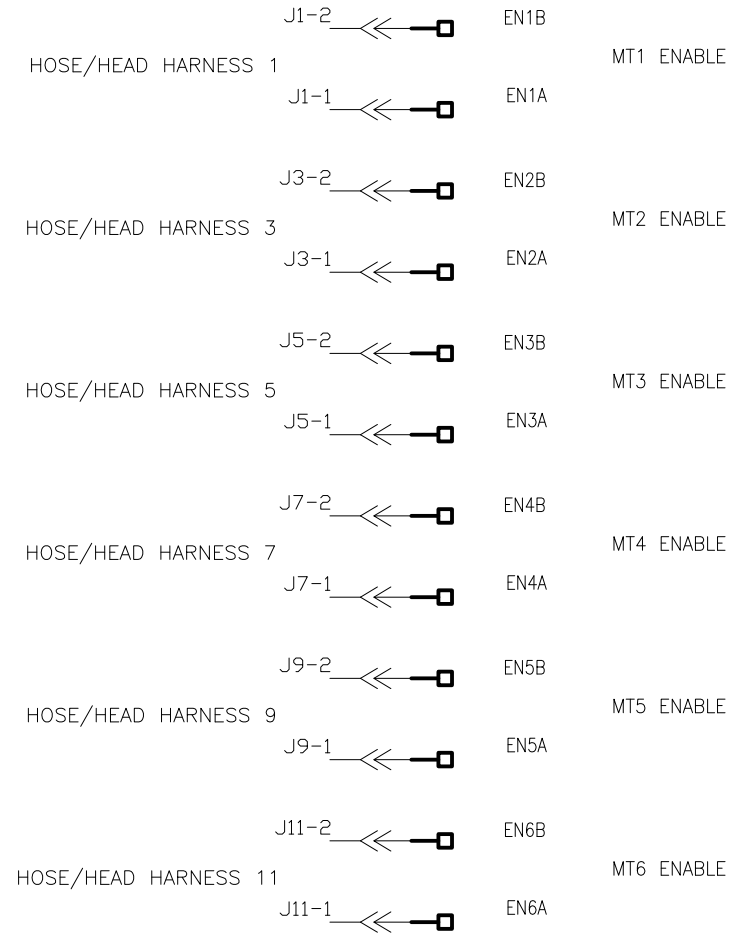

ITEM	PART NUMBER	QTY.	U/M	DESCRIPTION	PARTS LIST		
UNLESS OTHERWISE SPECIFIED DIMENSIONS ARE IN INCHES TOLERANCES ARE: FRACTIONS DECIMALS ANGLES ± .005 ± .010 ± .5°				FOR MACHINING STANDARDS AND SYMBOLS, SEE ITW/DYNATEC SPEC. A05800		 HENDERSONVILLE, TN	U/M
USED ON V6 M-SERIES				APPROVALS BFQ	DATE 07.18.16		EA
NEXT ASSY.				CHECKED		V6,M-SERIES TRIGGER WIRING	STATUS A
DO NOT SCALE DRAWING				COMPUTER DESCRIPTION(25 CHARACTERS) V6,TRIGGER WIRING	SCALE NONE		DWG. NO. 824665
						REV. GROUP A NA	SHEET 1 of 1

11.11 Schematics V6 Profinet Option, PN 121436

11.12 High-Flow Thermostat Wiring, M210 V6, PN 825199

THIS DRAWING IS THE PROPERTY OF ITW/DYNATEC.
 DO NOT REPRODUCE OR DISCLOSE TO
 OTHERS WITHOUT EXPRESS WRITTEN
 CONSENT OF ITW/DYNATEC.

REVISIONS					
REL.	REV.	DESCRIPTION	DATE	BY	APPROVED
CON	002	A ORIGINAL RELEASE	05.03.17	BFG	

HIGH FLOW HOPPER THERMOSTAT WIRING FOR V6 ONLY. FOR ALL OTHER CONTROLS TYPES SEE SCHEMATIC.

V6-BASE
 PN 115734

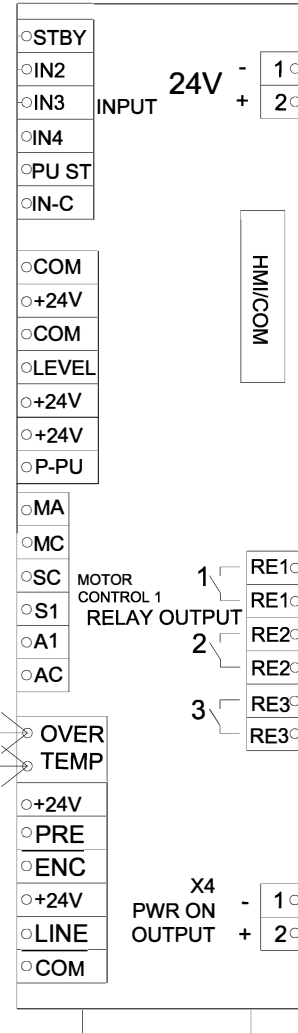
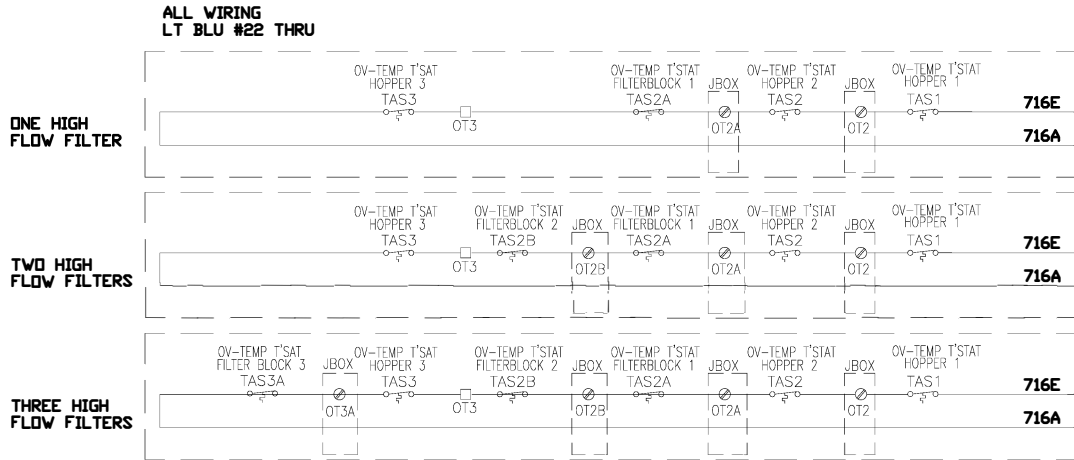

ITEM	PART NUMBER	QTY.	U/M	DESCRIPTION
PARTS LIST				
DO NOT SCALE DRAWING		TOLERANCES (UNLESS OTHERWISE SPECIFIED)		 HENNESSYVILLE, TN
COMPUTER DESCRIPTION(25 CHARACTERS)	NEXT ASSY:	STATUS:	DATE:	
	FOR MACHINING STANDARDS AND DIMENSIONS, SEE ITW/DYNATEC SPEC. ADDRESS	S	B	TITLE: SCHEM.V6.M210 HIGH FLOW THERMOSTAT WIRING
		E	A	SCALE: NONE DRAWN BY: BFG CHECKED BY: DATE: 05.03.17 SHEET 1 OF SHEETS 1 DRAWING NO. 825199

Chapter 12

Appendix

12.1 DynaControl V6 / Fieldbus Option

The V6 Fieldbus options allows any V6-based unit to be monitored and controlled remotely.

Available options are:

- Profibus
- ProfiNet
- Ethernet/IP
- EtherCAT
- CC-Link

Although those fieldbuses are different in several aspects, the data exchange between the remote controller (typically PLC) and the hot melt equipment is always the same. The data exchange is based on parameter tables (Input and Output Data).

The structure of the I/O tables allows easy access to commonly used information but also access to more in depth parameters if required.

The first half of the I/O tables are used to exchange important:

Input:

- Melter control: on/off/Standby
- Pump control: on/off pump speed
- Local or remote access

Output:

- System Status: ready, heating, warnings, alarm etc.
- Pump status: Run, Hold, actual pump speed
- Level indication
- Pressure read out

Those parameters are directly accessible without special PLC logic.

The second half of the I/O tables are used for block transfer. The block transfer can be used to exchange more detailed information. This is an on-demand transfer and requires PLC code to manage the transfer.

Following Blocks are available:

- Detailed system status
- Actual Temperature for each zone
- Read back of temperature set points
- Current temperature status
- Actual pressure for secondary transducers
- Temp. zone sequencing and zone on/off
- Pump speed manual setpoints
- Pump speed automatic scaling
- Pressure loop parameters

If parameters have to be changed that are not available within the predefined Blocks above, it is possible to create custom blocks. With this it is possible to access virtually every internal parameter. Since this requires special knowledge this is out of the scope of the standard documentation. If required a special technical instruction sheet is available on request.

Local access vs. remote access:

Once the system is controlled via field bus, the fieldbus takes priority over parameter change via HMI. In order to make local changes (on Melter's HMI) possible the PLC can grant access to those parameters.

The access is separated into global control and Line speed control.

12.2 Coalescing Filter Kit, PN 100055

4

3

2

1

DWG. NO. 100055 SH 1 REV. K

THIS DRAWING IS THE PROPERTY OF ITW/DYNATEC. DO NOT REPRODUCE OR DISCLOSE TO OTHERS WITHOUT EXPRESS WRITTEN CONSENT OF ITW/DYNATEC.

REL.	REV.	DESCRIPTION	DATE	BY	APPROVED
02163	G	ADDED ITEM 4	10.14.02	BB	
02584	H	ITEM 5 WAS 100380	10.30.02	BB	
02640	J	CORRECT VIEW OF FILTER	1.31.03	BB	
E436	K	SHOW ITEM 14 AS SPARE; ADD NOTE 2	07.09.19	JC	

REL.	REV.	DESCRIPTION	DATE	BY	APPROVED
	A	ORIGINAL RELEASE	04.22.94	CN	
	B	REQ. VALVE WAS 100041	05.10.94	CN	
	C	N06438 WAS N07677, QTY WAS 20FT 100380 WAS N02774 ITEM 6 WAS 100081 ITEM 12 WAS N01067	07.08.94	CN	
	D	1. WAS N02535 2. QTY WAS 20; 3. WAS N00754 4. WAS N02745; 5. WAS VLV, SDL 6. QTY WAS 5; 7. WAS N06412 8. WAS N06435; 9. WAS N00093 10. QTY WAS 3; 11. WAS N00092	08.26.94	CN	
	E	QTY WAS 5	01.12.95	JT	
00095	F	ITEM 14 WAS QTY 1, ADDED ITEM 3	2.10.00	BB	

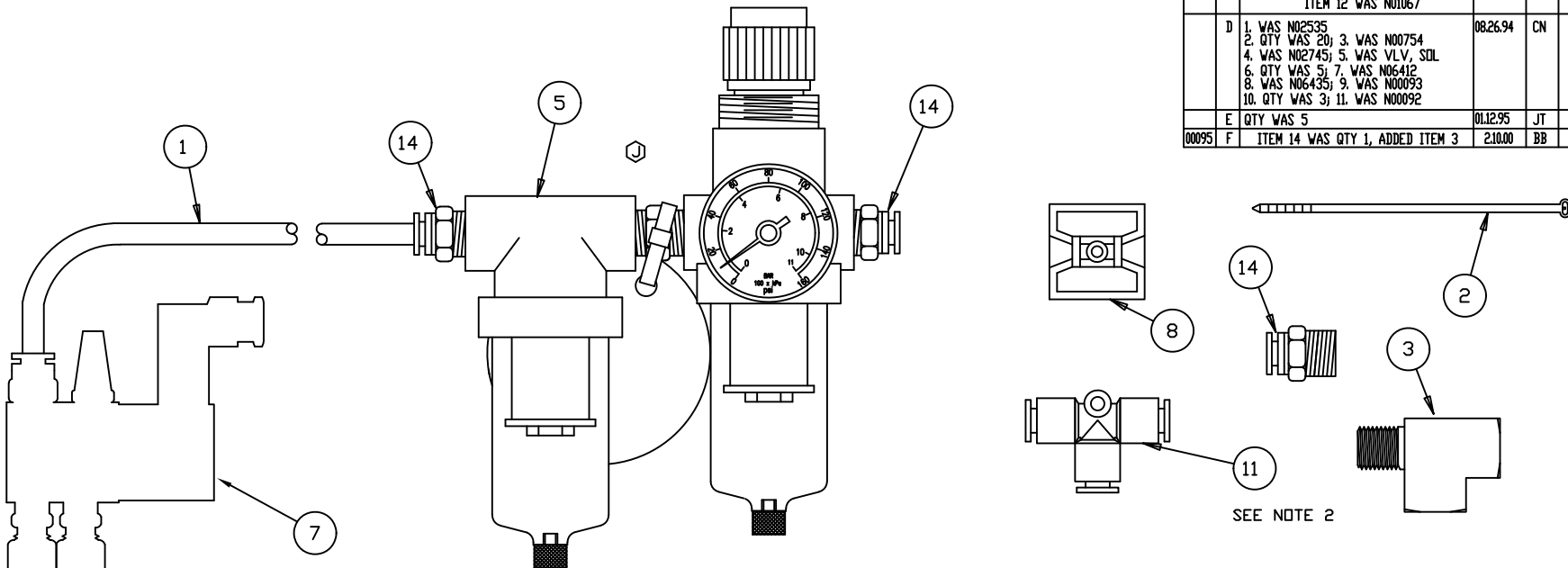

SEE NOTE 1

SEE NOTE 2

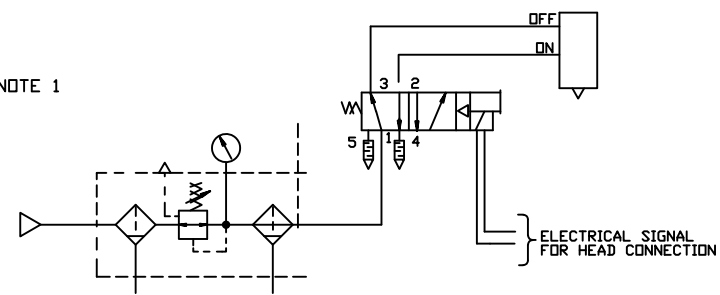

PNEUMATIC DIAGRAM FOR A-HEAD & S-HEAD CONTROL (24VDC)

NOTE:
 1. AIR LINES TO HEAD ARE TO BE CUT TO 3.5-4.0 INCHES LONG.
 2. BAG ALL LOOSE ITEMS WITH FILTER/REGULATOR ASSY AND MARK WITH ITW DYNATEC PART NUMBER FOR CUSTOMER USE.

ITEM	PART NUMBER	QTY.	U/M	DESCRIPTION
16				
15				
14	N06430	3	EA	FTG,CONN,M,BRS
13				
12				
11	N06504	1	EA	FTG,TEE,UNION,BRS,PUSH-IN
10				
9				
8	N04264	3	EA	CABLE TIE ANCHOR, ADH BKD
7	REQ. VALVE ASSY	1	EA	ASY,VLV,SDL
6				
5	105610	1	EA	FLTR,ASY,A/C
4	100055-REF	1	REF	DWG ASSY INSTR
3	N04531	1	EA	FTG,TEE,STREET,#04
2	N00318	10	EA	CABLE TIE,.09X3.62 LG WYL
1	N06438	10	FT	TUBING,NYLON,.250D

UNLESS OTHERWISE SPECIFIED DIMENSIONS ARE IN INCHES TOLERANCES ARE FRACTIONS DECIMALS ANGLES		FOR MACHINING STANDARDS AND SYMBOLS, SEE ITW/DYNATEC SPEC. A05800		 HENDERSONVILLE, TN	U/M
USED ON	APPROVALS	DATE	STATUS		EA
NEXT ASSY.	DRAWN	4.22.94	STATUS	P	
	CHECKED	JCZ	4.22.94	SOURCE	
	APPROVED			P	
DO NOT SCALE DRAWING	SIZE	DWG. NO.	REV.	GROUP	
	C	100055	K	100	
	SCALE 1:1	CAD DRAWING	SHEET 1 OF 1		

4

3

2

1

THIS DRAWING IS THE PROPERTY OF ITW/DYNATEC.
DO NOT REPRODUCE OR DISCLOSE TO
OTHERS WITHOUT EXPRESS WRITTEN
CONSENT OF ITW/DYNATEC.

REVISIONS				
REV	DATE	DESCRIPTION	REF DOC	BY
A	2.26.98	ORIGINAL RELEASE	N97062	JCZ
B	4.10.02	ITEM 2 WAS 105607	02196	BB
C	10.30.02	DELETED ITEMS 4-9, REVISED NOTES	02584	BB
D	10.14.09	ITEM 3 WAS 048J008	09290	BB
E	26JUL19	NOTE 1 DETAILED FLUSH PLUG INSTALL, NO LONGER NECESSARY	ECN 471	ALM

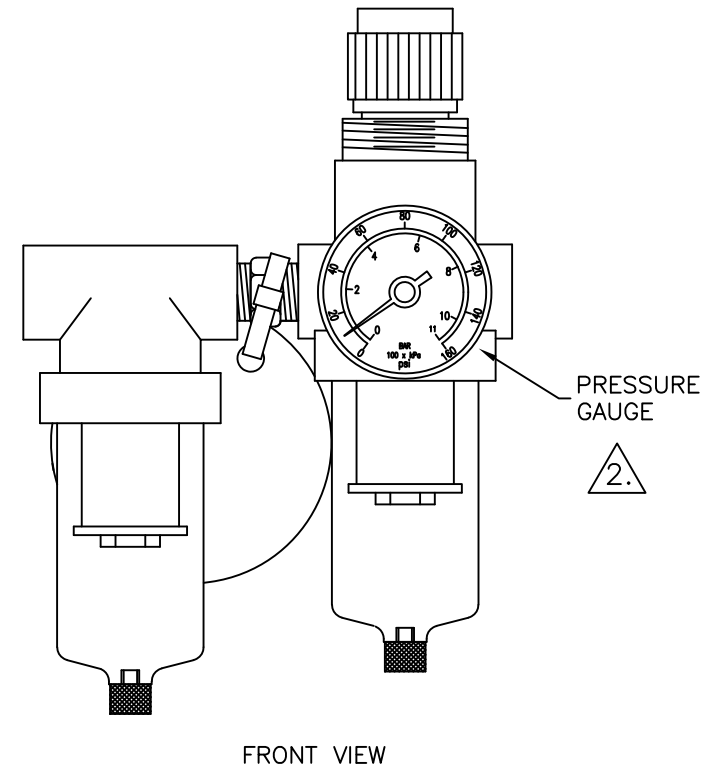
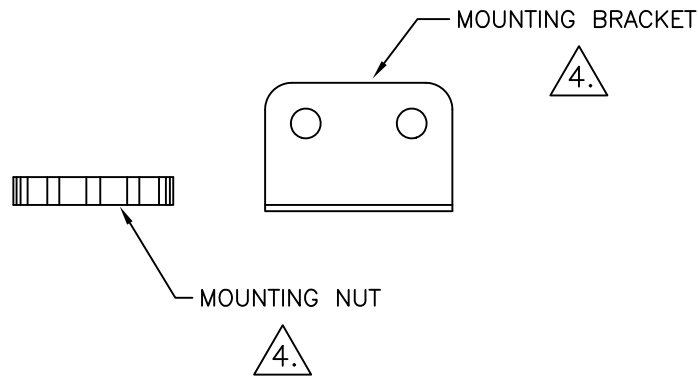
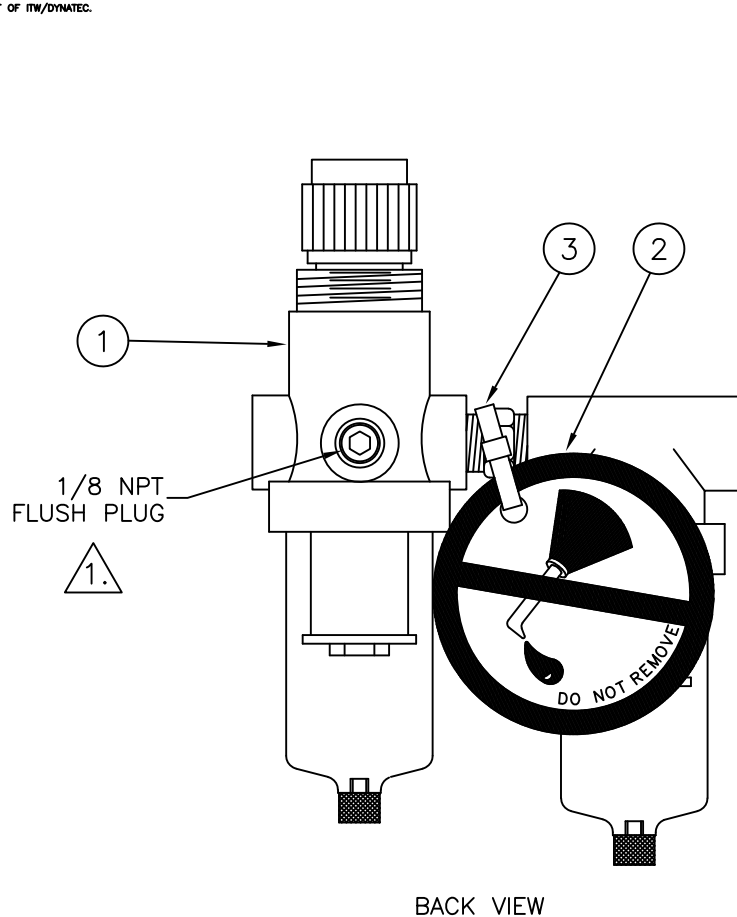

E NOTES:

1.

2. INSTALL GAUGE WITH FACE ORIENTATION AS SHOWN. PLACE TEFLON TAPE ON THREADS PRIOR TO ASSEMBLY.

3. ATTACH THE "DO NOT OIL" TAG (ITEM 2) TO THE FILTER/REGULATOR ASSY USING THE CABLE TIE (ITEM 3).

4.

MOUNTING NUT AND BRACKET ARE SUPPLIED WITH FILTER/REGULATOR ASSY (ITEM 1) AND MAY OR MAY NOT BE USED ON ASSEMBLY LINE. IF NOT USED, BAG WITH FILTER/REGULATOR ASSY AND MARK WITH ITW DYNATEC PART NUMBER FOR CUSTOMER USE.

3	N00318	1	EA	CABLE TIE,.09X3.62 LG WY
2	103053	1	EA	TAG,OIL FREE
1	100380	1	EA	FLTR/REG ASY,COALESCING
ITEM	PART NUMBER	QTY	U/M	DESCRIPTION

PARTS LIST				ITW Dynatec HENDERSONVILLE, TN		U/M EA
UNLESS OTHERWISE SPECIFIED DIMENSIONS ARE IN INCHES TOLERANCES ARE: FRACTIONS DECIMALS ANGLES ± .003 ±.010 ±.5				FOR MACHINING STANDARDS AND SYMBOLS, SEE ITW/DYNATEC SPEC. A05800		STATUS A SOURCE G GROUP 20
USED ON DYNAMELT & DYNAMINI	APPROVALS JCZ	DATE 2.26.98	FILTER/REGULATOR ASSEMBLY			
NEXT ASSY. —	CHECKED JCZ	2.26.98				
DO NOT SCALE DRAWING	COMPUTER DESCRIPTION(24 CHARACTERS) FLTR/REG AS,DMS/DMIN	SIZE C	DWG. NO. 105610	REV. E		
SCALE 1:1		CAD DRAWING		SHEET 1 of 1		

THIS DRAWING IS THE PROPERTY OF ITW/DYNATEC.
DO NOT REPRODUCE OR DISCLOSE TO
OTHERS WITHOUT EXPRESS WRITTEN
CONSENT OF ITW/DYNATEC.

DWG. NO. 100380 SHT. 1 REV. C

REVISIONS					
REL.	REV.	DESCRIPTION	DATE	BY	APPROVED
02584	C	REVISED AND REDRAWN	10.30.02	BB	

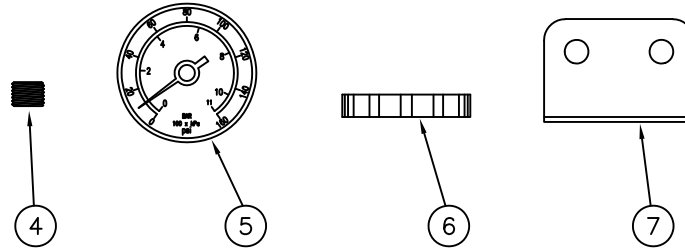
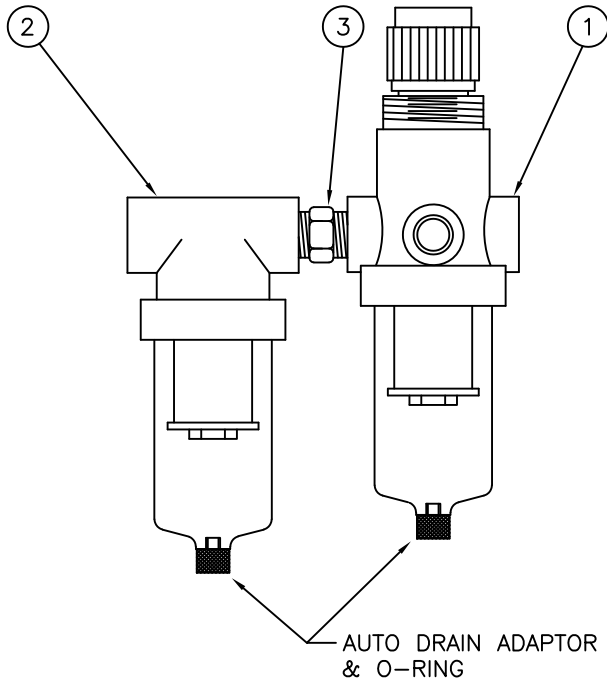

ITEM	PART NUMBER	QTY.	U/M	DESCRIPTION
7	—	1	EA	BRACKET, MOUNTING
6	—	1	EA	NUT, MOUNTING
5	—	1	EA	GAUGE, PRESSURE
4	—	1	EA	PLUG, FLUSH, 1/8 NPT
3	072X228	1	EA	FITTING, PIPE NIPPLE, 1/4 NPT
2	100081	1	EA	FILTER, COALESCING, 1/4 NPT
1	N02774	1	EA	FILTER/REGULATOR, 1/4 NPT

NOTES:

- VENDOR: FLUID POWER; VENDOR P/N CQ491
- ITEMS 4-7 ARE SUPPLIED UNASSEMBLED AND BAGGED WITH THE FILTER/REGULATOR ASSEMBLY.

PARTS LIST			
UNLESS OTHERWISE SPECIFIED DIMENSIONS ARE IN INCHES TOLERANCES ARE: FRACTIONS DECIMALS ANGLES ± .010 ±.005 ±.5		FOR MACHINING STANDARDS AND SYMBOLS, SEE ITW/DYNATEC SPEC. A05800	
USED ON	APPROVALS	DATE	 HENDERSONVILLE, TN FILTER/REGULATOR ASSEMBLY, COALESCING
NEXT ASSY. 105610	DRAWN BB	10.30.02	
DO NOT SCALE DRAWING	CHECKED	COMPUTER DESCRIPTION(24 CHARACTERS) FLTR/REG ASY,COALESCING	U/M EA STATUS P SOURCE SIZE DWG. NO. 100380 SCALE 1:1 CAD DRAWING SHEET 1 of 1

12.3 Gear Pumps

Gear Pumps, Safety and Operation



WARNING

These instructions should be read thoroughly by all personnel involved with pump operation prior to pump installation, operation, or maintenance.



ATTENTION

If operation of this pump is critical to your business, we strongly recommend you keep a spare pump in stock at all times. As a minimum, a seal kit (O-rings, gaskets, and shaft seal) should be kept in stock so pump refurbishment after internal inspection can be accomplished.

General Description

ITW Dynatec's metering gear pumps are manufactured to precise tolerances. To retain their high performance, these pumps must be carefully installed and maintained. These pumps are CE (Declaration of Conformity) rated.

The gear pumps are positive-displacement. A single, drive shaft transmits force / torque to one or more driving gears, which then engage and deliver force / torque to one or more driven gears. Fluid is directed into the pump through the inlet stream(s). The fluid fills the exposed spaces between the gear teeth, then is conveyed around the inside of the gear housing as the gears turn. Once the path is completed, the gear teeth mesh together and the fluid is displaced. The fluid flows out of the pump through the discharge port(s). There may be multiple, driven gears, each with its own, associated discharge port. There may be single or dual stream pump assemblies.

This manual will not cover all situations which might arise with regard to installation, operation, inspection and maintenance of the pump supplied. ITW Dynatec assumes the personnel assigned to install, operate and maintain the supplied equipment have sufficient technical knowledge to apply generally accepted safety and operational practices, which may not be otherwise covered.

Gear Pump types

Code	PN	Delivery rate cc/rev	Pump Type	Shaft seal PN
GAS	100860	1.54	Single	069X061
GBS	100861	3.18	Single	069X061
GCS	100862	4.5	Single	069X061
GAD	100863	1.54	Dual	069X061
GBD	100864	3.18	Dual	069X061
SGD	108874 *	2.92	Dual	807729
SHS	108875 *	8.5	Single	807729
GES	109690	10.0	Single	069X061
GFS	109694	20.0	Single high-flow	069X061
GDS	109908	0.55	Single	069X061
GDD	109909	0.55	Dual	069X061
SIS	110289 *	20.0	Single high-flow	808680
SJS	110290 *	30.0	Single high-flow	808680
SKS	110291 *	45.0	Single high-flow	808680
GGs	111253	0.15	Single	069X061
GGD	111254	0.15	Dual	069X061
ZLS	084E372 *	0.16	Single	807729
ZES	084E374 *	0.584	Single	807729
ZLD	084E387 *	0.16	Dual	807729
ZDD	084E388 *	0.297	Dual	807729
ZED	084E389 *	0.584	Dual	807729
ZDS	084E428 *	0.297	Single	807729
ZFS	084E430 *	1.168	Single	807729
ZFD	084E432 *	1.168	Dual	807729
ZGS	084E434 *	2.92	Single	807729

* TSHA = Tool Steel, High Accuracy

General Safety Instruction



WARNING

- Installation, operation, and maintenance instructions must be correctly and strictly followed, otherwise, injury to personnel or serious damage to the pump could result.
- ITW Dynatec cannot accept responsibility for unsatisfactory performance or damage resulting from failure to comply with instructions.
- Only trained operators or trained, specialized personnel may handle or operate the pump.
- Always wear proper personal protective equipment. (i.e. Safety glasses, steel-toed shoes, face shield, protective clothing, gloves, respirator, dust mask, etc., as required for safe practices).
- Do not run the pump dry, or with no inlet fluid flow. Make sure the pump is only operated with, and never without, liquid filling the pump housing.
- Do not remove safety guards or other protective devices prior to installation or during operation.
- Be certain all safety devices, machine safety guards, protective electrical connections, temperature monitoring devices, pressure monitoring devices and sealing apparatus are installed and operational prior to starting the pump.
- Pumps may not be used with foodstuffs.
- Do not allow the pump to change temperature rapidly.
- Do not apply open flame to a pump.
- Do not allow leaking fluid to combust.
- Do not expose the pump to liquid nitrogen or other extremely cold substances.
- Do not attempt to quench a hot pump by applying water or other cool liquid to the surface.

If the pump is to be preheated or cooled prior to installation, heat or cool the pump to the operating temperature by use of an approved method, such as a band heater, bar heater, oven, cooling or environmental chamber, liquid bath or heating jacket, which can fully reach the operating temperature of the pumping system. Monitor the pump temperature and ensure the target temperature has been met and maintained. Allow ample time to heat-soak the pump thoroughly and evenly (including the seal arrangement).

- The manufacturer's warranty will be void if any part is replaced, or the pump is modified in any way, without permission from ITW Dynatec.

Installation



WARNING

- Follow all General Safety Instructions.
- Ensure pump is free from protective packing materials and rotates freely.
- Only use the pump as intended, while remaining aware of safety risks, and in adherence to the instructions in this manual.
- **Pump Drive:**
Drive alignment is very important. Ensure backlash is 0.1mm (0.004”) to avoid shock or radial load. In the event of drive shaft connection, two flexible components must be incorporated into each drive shaft to allow for misalignment. These flexible components must have the capacity to distort over the misalignment range while ensuring that any radial load is minimal. Do not allow shaft to put end thrust on the pump.
- **Rotation:**
Ensure drive rotates in correct direction. The pump must be checked for smooth operation by hand.
- **Fixing and Lubrication:**
The pump must be fixed securely to maintain position and alignment. When secured by lubricated bolts, torque them evenly to the suggested torque (see Maintenance).

Start drive and bring up to speed slowly. Flush with process fluid.

Note: motor base plate assemblies should be pre-checked in case the drive alignment has been disturbed.

- In order to ensure normal functioning of the pump and system, monitor the pressure at the outlet of the pump. The monitoring locations should be in the outlet port connections.
- Monitor the pump temperature, after installation and during operation. Note sudden changes in temperature which do not correlate with sudden changes in the temperature of the process liquid. If sudden temperature changes occur, shut down the pump operation and contact trained, specialized personnel for inspection and maintenance.
- Rotate the pump drive shaft by hand after mounting and fully tightening the mounting bolts. The shaft should turn freely.

Operation



WARNING

- Follow all General Safety Instructions.
- Measures must be taken to avoid skin contact. Wear protective clothing.
- Downstream pressure can change rapidly once the pump is started. If the downstream flow passages are blocked or valves are closed, the pump will likely reach dead-head condition before valves can be opened or the blockage removed.

Dead-head condition occurs when the pump reaches maximum pressure achievable at a given speed, with a given fluid viscosity.

Reaching the dead-head condition may cause the pump to fail, or for piping limits to be exposed. Dead head occurs whenever the pump is operating but the applicators are not dispensing.

- Measure the pump temperature after installation, and monitor temperature during operation. Rapid changes in temperature, while process temperatures and ambient temperatures are stable, signals a pending failure.

Safety Notes on Start-Up

- Check to insure that all process safety devices are in place and operational.
- Be certain the pump is fully lubricated and full of fluid prior to starting the motor.
- Be certain the pump temperature has fully reached the process temperature prior to starting the motor. Heat soak the pump sufficiently to ensure all recesses are at process temperature.
- Pump outlet pressure and speed limits are dependant on fluid viscosity and throughput. Pump inlet pressure is an important feature for lubrication and fluid stability. Materials for pump construction are important for corrosion and wear resistance. Consult ITW Dynatec for detailed applications. Normally the pumps are single or dual output. Typical speed ranges are 10-90 rev/ min.
- To avoid contamination of process fluid, the pump should be flushed out to remove test oil. Precaution must also be taken to flush out pumps at plant shutdown, since congealed fluid can cause seizure, when operating PUR.
- Unless fluid purity can be guaranteed (especially from metal fragments), filtration must be installed before pump inlet, to avoid damage to pump internals.
- During start-up, start the motor with a low speed set point, then gradually increase speed to the intended operating speed. An acceleration rate of 20 rpm / sec or less is recommended; 5 rpm / sec is a good starting point, allowing ample acceleration time for downstream apparatus to fill gradually with fluid, and for pressure to rise slowly.
- If at any time during operation the pump does not appear to be running smoothly, or unusual noise is heard, stop the pump immediately to limit internal damage and contact ITW Dynatec!

Heating, Cooling During Operation

If the pump is to be operated outside of room temperature 10°C (50°F) – 45°C (113°F), care must be taken to ensure the process temperature is met and maintained prior to and during operation. Monitor the pump temperature and ensure the target temperature has been met and maintained. Allow ample time for the pump to adjust and stabilize. Ensure any temperature changes occur gently, thoroughly and evenly (including the seal arrangement).

Protect the pump from thermal shocks of greater than 28°C (50°F). Rapid temperature changes must be avoided.

Shutdown

The pump will need to be purged of the process fluid during shutdown. Use of a purging liquid (an inert, lubricating liquid which is safe to the pump and personnel,) is recommended, rather than simply attempting to drain the process fluid from the pump.

Run the pump slowly during the purging process in order to ensure no damage occurs.

Separate the coupling components, connecting the pump shaft to the gearbox or motor, and turn the pump by hand, or with a wrench, when completing the purging and draining.

If no purging liquid is available, and the pump will be run in order to facilitate draining, be cautious to complete the operation in less than 1 minute.

If the pump is to be stored, or if it will sit for a long period without operation or protection, apply rust preventative oil to all internal and external surfaces.

Restarts

On restart, where the product fluid has hardened and solidified in the pump during the shutdown, the fluid must be softened and made completely liquid again prior to restarting the pump. If the product fluid can be softened by heating, preheat the pump and allow the product to completely melt.

If the product fluid cannot be softened easily, or if the hardening of the product fluid is not reversible, the pump must be cleaned prior to restarting.



WARNING

- Take care the product has not changed properties.
- Ensure the fluid is still capable of providing lubrication to the pump internal components.
- Restart slowly and gradually.
- During preheat; do not let polymer sit inside the pump more than 5 hours, due to the risk of breakdown and conversion of the polymer. Breakdown or conversion would result in unsatisfactory lubrication of the pump bearings at start-up and cause pump failure.

Airborne Noise

- Under normal operating conditions, the airborne noise level will be less than or equal to 70 dB.
- If airborne noise levels above 70 dB are noted, the pump is not operating under normal conditions or component failure is imminent. Contact your ITW Dynatec representative for assistance.

Maintenance

Tightening Torque for High Tensile ISO 12.9 Lubricated Bolts (572°F max. / 300°C max.)

Bolt Size & Qty.	Bolt Location	Torque Nm/ Ft.lbs.
M5 (4)	Retainer cap	7.1/ 5.2
M10, 12 (4)	Mounting bolts	41/ 30 at ambient temperature
M10, 12 (4)	Mounting bolts	24/ 18 at production temperature

Notes: If mounting bolts are torqued at production temperature, they should be re-torqued (to 41 Nm/30 Ft lb.) when machine is at ambient temperature.

1 Nm = 8.85 in/lbs. Torques given above are for Metric and UNF threads. Multiply by 0.8 for UNC and BSF threads. Multiply by 0.8 for BSVV threads (multiply by 0.67 for stainless steel).

ITW Dynatec frequently provides special features at their customer's request. Please consult with ITW Dynatec, quoting job and pump references, if questions arise.

Maintenance Notes



WARNING

- Seal failure will eventually occur. Develop a plan to deal with this situation. Take appropriate safety measures if liquid is hazardous.
- BEFORE starting any maintenance procedure, do the following:
Shut off all power switches and circuit breakers.
Remove any electrical service fuses.
Lock electrical service panel supplying power to system.
Shut, wire or chain, and lock all valves in pump inlet/outlet hose.
If applicable, shut off any pneumatic or other fluid supply lines to the pump.

- Visually check equipment frequently for signs of damage or leakage from shaft seals, gaskets or O-rings.
- Be sure all connections are tight.
- If seal leakage is more than about 10 drops per hour per seal, shut down equipment and repair or replace necessary parts.
- Shaft seals have a limited, finite life which is affected by operating conditions and environment. Expect them to wear and eventually fail. When leakage becomes unacceptable, replace the seal unit with the correct replacement unit, one compatible with pump's operating conditions. Dirty liquids will reduce seal life.
- Cleaning fluids and methods are subject to strict Health and Safety regulations. Avoid contact with skin, do not inhale fumes and protect eyes.
- Packing seals should be replaced when all packing follower travel is exhausted or when packing is damaged and leakage cannot be controlled.
- Where pump out-of-service time is of vital concern and down-time must be minimized, kits of spare parts and seals should be acquired before needed and retained on-site.
- Only trained, specialized personnel, using the appropriate Original Installation, Care and Maintenance Instructions, can perform maintenance, which includes, but is not limited to, Inspection, Repair, Assembly and Disassembly.
- Contact ITW Dynatec for information on having personnel trained.

Pump shaft Leakage

If shaft seal leakage is present the seal should be replaced.

If the pump uses Packing seals:



WARNING

- Slight leakage is necessary to lubricate the packing.
- If not appropriately collected, packing leakage may make floor slippery and/or expose personnel to hazardous fluids. Collect packing leakage properly and safely.
- Tighten the packing follower screws in a crossing pattern, gradually, until the packing is evenly compressed and the leakage diminishes to near zero, then loosen each of the screws, gradually, ¼ turn at a time, until slight leakage occurs. Slight leakage is necessary in order to lubricate the packing and the shaft.
- Be certain to adjust the packing follower properly.
- Do not over-tighten the packing follower. Over-tightening will cause damage to the packing and the shaft.
- Other sealing options are available.
- Re-adjust the packing follower several times through the running-in period, until the seal is thoroughly seated and the rate of leakage is stable.

Cleaning

Before removal from machine, the pump should be rotated for a short period (with inlet supply shut off) to discharge process fluid. Care should be taken, when removing and stripping the pump, to allow for any residual fluid. Pump components can be solvent or ultrasonically cleaned by immersion, using a compartmentalized wire basket. Dry in air. Stubborn residues may be removed with a brass wire brush. Avoid burnishing the sharp edges of gear and gear races.

Fluid immersion in rust inhibitor is advised. If components are to be stored for some time, they should be lightly coated with oil.

Troubleshooting

Problem	Possible Cause	Solution
Pump leaks	Screws not tight.	Re-torque screws to recommended tightening torque.
	Seal scratched or worn.	Replace seal.
Pump will not turn.	1. Low pump temperature.	Check temperature sensor and control loop for proper setting/ operation. Allow sufficient heat-up time.
	2. Drive malfunction.	Verify drive is powered. Check to assure all alarm circuits are clear. Check drive motor current and speed settings. Check all drive couplings.
	3. Process conditions changed.	Check process conditions for proper melt temperature, pressures, viscosities and materials.
	4. Foreign particle.	Send pump for repair to ITW Dynatec.
	5. Possible internal damages.	Send pump for repair to ITW Dynatec.
Excessive seal assembly leakage	1. Worn seal plate.	Send pump for repair to ITW Dynatec.
	2. Low temperature pump start.	Increase temperature. Allow heat soak time.
	3. Worn lip seal.	Replace lip seal.
Reduced pump efficiency / Error with pump delivery	1. Worn gears/ bearings/ plates.	Send pump for repair to ITW Dynatec.
	2. Process conditions changed: <ul style="list-style-type: none"> • Low inlet pressure (cavitation). • High outlet pressure (slippage). 	Check and adjust the recommended process conditions.

Reconditioning

Should reconditioning (overhauling) become necessary, return the pump to ITW Dynatec.

Pump Shaft Seal Replacement

The ITW Part Number for all Tool Steel High Accuracy Pump Shaft Seals (8.5cc and smaller) is PN 807729.



DANGER HOT SURFACE & HIGH VOLTAGE

If the pump is not operable but the heating system will function, raise the temperature of the application system to the operating temperature to aid in the pump disassembly process. Otherwise, a heat gun or other controlled heating method is recommended to melt hardened hot melt material. Never use a torch or an open flame on any of the components of the application system. Once the system is up to temperature, disconnect all incoming power before proceeding.

Pump Shaft Seal (O-ring) Replacement:

In most cases, the pump does not have to be removed from the ASU in order to replace the shaft seal.

1. Disconnect the drive coupling so that the pump may be accessed.
2. Remove the four screws in the pump “cap” and remove the cap
3. Within the cap is the pump shaft seal. Remove the old seal.
4. Clean all pump parts, paying particular attention to the pump shaft seal groove.
5. Lightly lubricate the shaft seal before inserting it in the shaft seal groove.
6. Before re-assembling, wrap a small piece of paper around the shaft so that the shaft’s woodruff key seat does not damage the new seal.
7. Re-assemble. Remove paper
8. Re-tighten four screws.
9. Re-connect drive coupling.
10. Return ASU to operation and check pump for leaks.

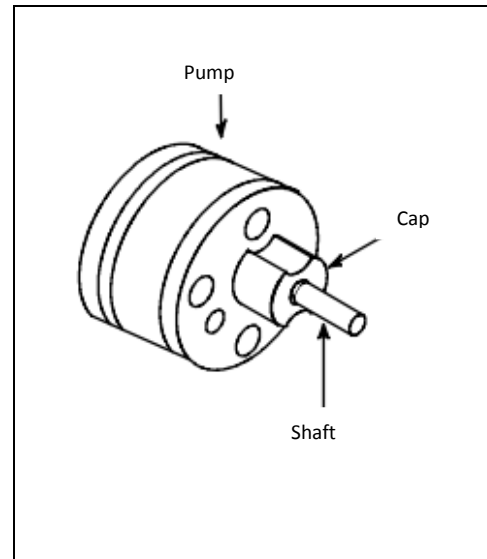

Transport / Storage



DANGER

- Death or crushing of limbs caused by falling or overturning loads!
- Bodily harm can occur if excessive weight is lifted or moved incorrectly!
- Protection from hot surfaces and hot liquids must be provided by the operator!

Take care not to drop the pump. Read and consider the weight prior to attempting to lift or move the pump. Do not attempt to lift pumps heavier than 25 kg without the use of a crane or other type of lifting assist device. Only qualified personnel may transport pumps weighing more than 25 kg.

When working with pumps that are hot, wear proper protective equipment and note that hot fluid may flow from the pump. Guard against skin contact with hot fluids, or with a hot pump. Follow all precautions of the fluid manufacturer in the handling of the fluid.

In the event that a pump needs to be stored, always protect the pump against water and other contaminants. Store the pump in a clean, dry, and warm environment. Pumps are delivered filled with suitable lubricant and with protective covers in, or over, all openings. These covers should remain in place during the mounting and alignment procedures, as long as possible. Remove the covers just prior to attaching system hoses to the manifold.

While storing spare parts, always protect the parts from water and contaminants. Store the parts in a clean, dry, and warm environment. Spare parts should be lightly coated with rust preventative oil and sealed in an air tight container.

12.4 Signal Isolator

Signal Isolator, V6, PN 117143

General Description

The isolated converter DAT 4531 D is able to measure voltage and current signals. In function of programming, the measured values are converted in a current or voltage signal. The device guarantees high accuracy and performance stability both versus time and temperature.

The programming is made by dip-switch located in the window on the side of the enclosure. By means of dip-switches it is possible to select the input type and range and the output type without recalibrate the device.

Moreover, by Personal Computer the user can program all of the device's parameters for his own necessity.

The 1500 Vac galvanic isolation on all ways (input, output and power supply) eliminates the effects of all ground loops eventually existing and allows the use of the converter in heavy environmental conditions found in industrial applications.

The DAT 4531 D is in compliance with the standard 89/336/CEE on the Electromagnetic Compatibility. It is housed in a plastic enclosure of 12.5 mm thickness suitable for DIN rail mounting in compliance with EN-50022 and EN-50035 standards.

User Instructions

The converter must be powered by a direct voltage applied to the terminals Q and R.

The input channel measures the value from the sensor connected to the terminals I, L and G and transmits the output measure on the terminals N and M.

The input and output connections must be made as shown in the section "Connections".

It is possible to configure the converter on field by dip-switch or Personal Computer as shown in the section "Programming".

The configuration by dip-switches can be made also if the device is powered (Note: after the configuration the device takes some seconds to provide the right output measure).

Light Signalling

LED	COLOR	STATE	DESCRIPTION
PWR	GREEN	ON	Device powered.
		OFF	Device not powered
		BLINKING	Wrong dip-switches setting

Programming

Configuration by DIP-Switches

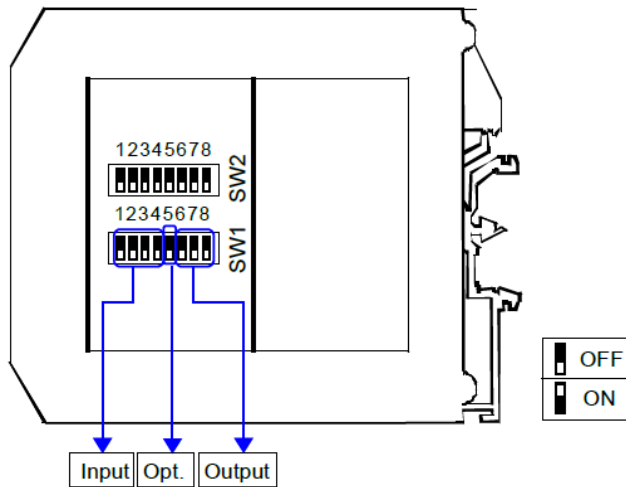

- 1) Open the suitable door on the side of the device. Refer to TAB.1.
- 2) Set the input type by the dip-switch SW1 [1..4].
- 3) Set the output type by the dip-switch SW1 [6..8].
- 4) Set the options type by the dip-switch SW1 [5].

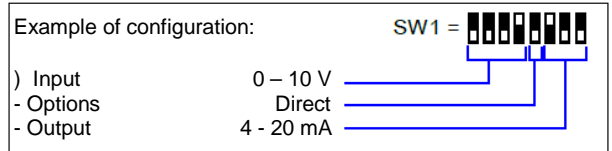

NOTE:

It is also possible to set the dip-switches using the wizard of the configuration software following the procedure described in the section “Configuration by PC” until the step 6 and clicking on “Switch”.

DIP-Switch Configuration Tables

TAB.1 - Settings

Input	Output	Options
SW1 1 2 3 4	SW1 6 7 8	SW1 5 Out:
Default *	0÷20 mA	Direct
0÷20 mA	4÷20 mA	Reverse
4÷20 mA	0÷10 V	
0÷10 V	2÷10 V	
2÷10 V	0÷5 V	
0÷5 V	1÷5 V	
1÷5 V		

NOTES:

* If the dip-switches SW1 [1..4] are all set in the position 0 (“Default”), the device will follow the configuration programmed by PC (Input and output type and options).

* Eventual wrong dip-switches settings will be signalled by the blinking of the LED “PWR”.

12.5 Pressure Transducer

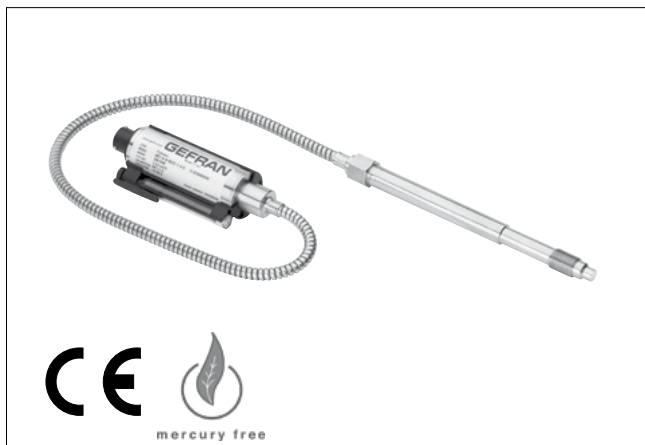

The WE series of Gefran, are pressure transmitters for using in High temperature environment.

The main characteristic of this series is the capability to read temperature of the media up to 315°C.

The constructive principle is based on the hydraulic transmission of the pressure.

The fluid-filled system assures the temperature stability. The physical measure is transformed in a electrical measure by means the strain-gauge technology.

MAIN FEATURES

- Pressure ranges from:
0-35 to 0-1000 bar / 0-500 to 0-15000 psi
- Accuracy: $< \pm 0.25\%$ FSO (H); $< \pm 0.5\%$ FSO (M)
- Fluid-filled system for temperature stability
- Oil filling meets FDA requirements CFR 178.3620 and CFR 172.878
- Oil filling volume:
WE0 (30mm³); WE1, WE2, WE3 (40mm³)
- 1/2-20UNF, M18x1.5 standard threads; other types available on request
- Other diaphragms available on request
- Autozero function on board / external option
- Drift Autocompensation function (SP version)
- 17-7 PH corrugated diaphragm with GTP+ coating

GTP+ (advanced protection)

Coating with high resistance against corrosion, abrasion and high temperature

AUTOZERO FUNCTION

All signal variations in the absence of pressure can be eliminated by using the Autozero function.

This function is activated by closing a magnetic contact located on the transmitter housing.

The procedure is permitted only with pressure at zero.

AUTOCOMPENSATES INFLUENCE OF MELT TEMPERATURE

Thanks to internal self-compensation, the WSP series transmitter cancels the effect of pressure signal variation caused by variation of Melt temperature.

This reduces at the minimum the read error caused by heating of the filling fluid (typical of all sensors built with "filled" technology).

TECHNICAL SPECIFICATIONS

Accuracy (1)	H $< \pm 0.25\%$ FSO (100...1000 bar) M $< \pm 0.5\%$ FSO (35...1000 bar)
Resolution	Infinite
Measurement range	0..35 to 0..1000bar 0..500 to 0..15000psi
Maximum overpressure (without degrading performances)	2 x FS 1.5 x FS above 500bar/7500psi
Measurement principle	Extensimetric
Power supply	10...30Vdc
Maximum current absorption	32mA
Insulation resistance (at 50Vdc)	>1000 MOhm
Output signal Full Scale (FSO)	20mA
Zero balance (tolerance $\pm 0.25\%$ FSO)	4mA
Zero signals adjustment (tolerance $\pm 0.25\%$ FSO)	"Autozero" function
Span adjustment within $\pm 5\%$ FSO	See Manual
Maximum allowed load	See diagram
Response time (10...90% FSO)	~ 1ms
Output noise (RMS 10-400Hz)	< 0.025% FSO
Calibration signal	80% FSO
Output short circuit ingress and reverse polarity protection	YES
Compensated temperature range	0...+85°C
Operating temperature range	-30...+105°C
Storage temperature range	-40...+125°C
Thermal drift in compensated range: Zero / Calibration / Sensibility	< 0.02% FSO/°C
Diaphragm maximum temperature	315°C / 600°F
Zero drift due to change in process temperature (zero)	< 0.04 bar/°C
Zero drift temperature for Autocompensated version (SP) within the temperature range 20°C-315°C inclusive the drift temperature of the housing	< 0.005 bar/°C 100 \leq p < 500 bar 0.0022 %FS/°C p \geq 500 bar
Standard Material in contact with process medium	Diaphragm: • 17-7PH corrugated diaphragm with GTP+ Stem • 17-4 PH
Thermocouple (model WE2)	STD: type "J" (isolated junction)
Protection degree (with 6-pole female connector)	IP65

FSO = Full scale output

(1) BFSL method (Best Fit Straight Line): includes combined effects of Non-Linearity, Hysteresis and Repeatability.

MECHANICAL DIMENSIONS

WE0

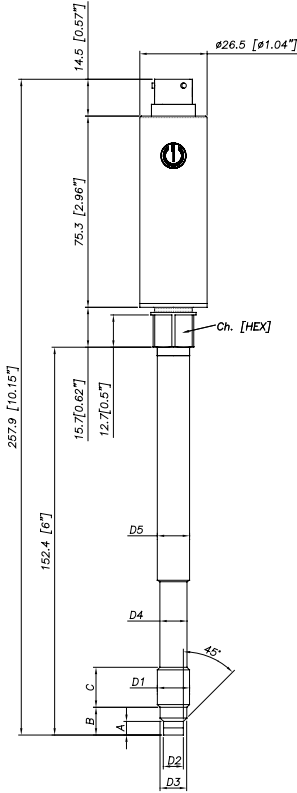

D1	1/2 - 20UNF
D2	$\phi 7.8 - 0.05$ [$\phi 0.31$ " - 0.002]
D3	$\phi 10.5 - 0.025$ [$\phi 0.41$ " - 0.001]
D4	$\phi 10.67$ [$\phi 0.42$ "]
D5	$\phi 12.7$ [$\phi 0.5$ "]
A	5.56 - 0.26 [0.22" - 0.01]
B	11.2 [0.44"]
C	15.74 [0.62"]
Ch	16
[Hex]	[5/8"]

WE2

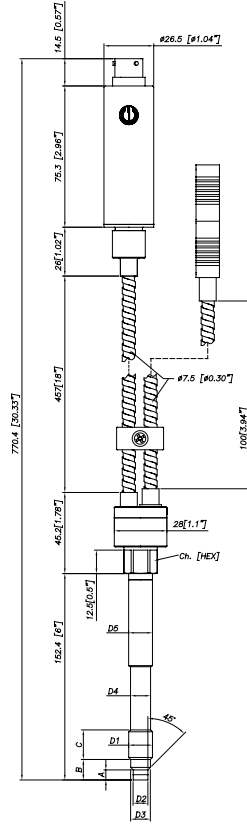

WE3

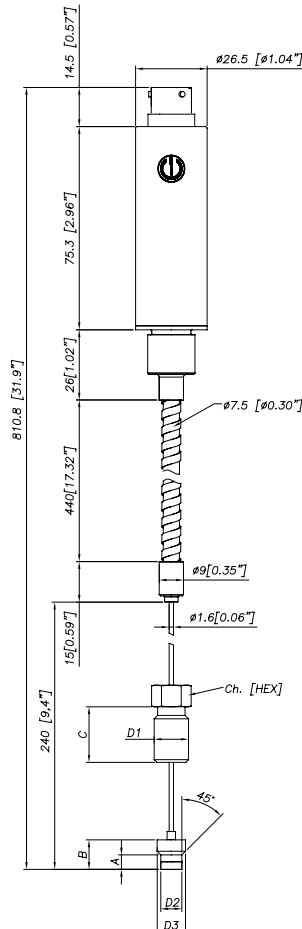

Exposed capillary	
D1	1/2-20UNF
D2	.307/.305" [7.80/7.75mm]
D3	.414/.412" [10.52/10.46mm]
A	.125/.120" [3.18/3.05mm]
B	.318/.312" [8.08/7.92mm]
C	.81" [20.6mm]

D1	M18x1.5
D2	$\phi 10 - 0.05$ [$\phi 0.394$ " - 0.002]
D3	$\phi 16 - 0.08$ [$\phi 0.63$ " - 0.003]
D4	$\phi 16 - 0.4$ [$\phi 0.63$ " - 0.016]
D5	$\phi 18$ [$\phi 0.71$ "]
A	6 - 0.26 [0.24" - 0.01]
B	14.8 - 0.4 [0.58" - 0.016]
C	19 [0.75"]
Ch	19
[Hex]	[3/4"]

NOTE : dimensions refer to rigid stem length option "4" (153 mm – 6")

WARNING : For installation use a maximum tightening torque of 56 Nm(500 in-lb)

ELECTRICAL CONNECTIONS

CURRENT OUTPUT (4...20mA, two wires)

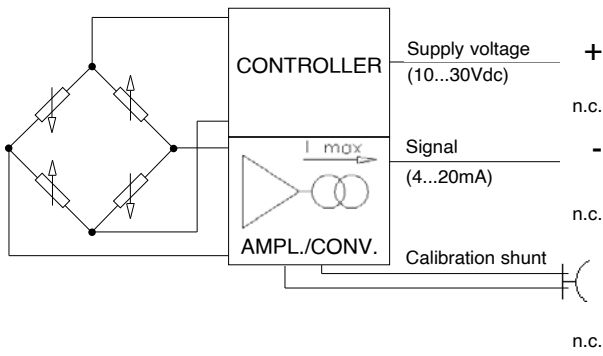

6 pin connector
VPT07RA10-6PT2
(PT02A-10-6P)

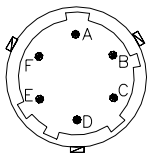

8 pin connector
PC02E-12-8P Bendix



MAGNETIC AUTOZERO

6-pin	8-pin
A	B
C	A
B	D
D	C
E - F	E - F
	G - H

Shield drain wire is tied to connector via cable clamp

EXTERNAL AUTOZERO

6-pin	8-pin
A	B
C	A
B	D
D	C
E - F	E - F
	G - H

LOAD DIAGRAM

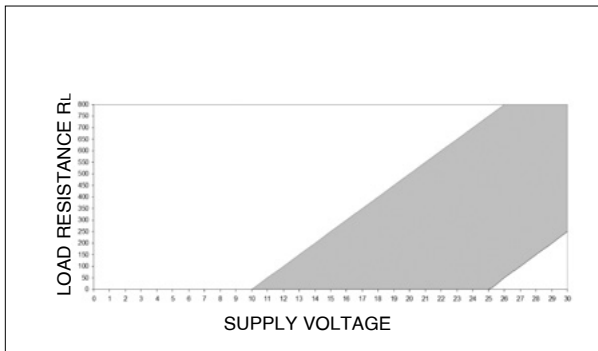

The diagram shows the optimum ratio between the load and supply voltage of the 4...20mA transmitter. For a correct use, choose any combination of load resistance and supply voltage, in the shaded area.

AUTOZERO FUNCTION

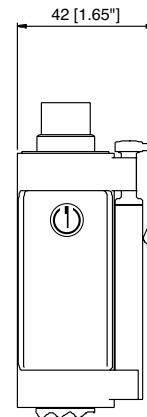

The Autozero function is activated through a magnetic contact (external magnet supplied with the sensor). See the manual for a complete Autozero function explanation.

ACCESSORIES

Connectors

- 6-pin mating connector (IP65 protection degree)
- 8-pin mating connector

Extension cables

- 6-pin connector with 8m (25ft) cable
- 6-pin connector with 15m (50ft) cable
- 6-pin connector with 25m (75ft) cable
- 6-pin connector with 30m (100ft) cable
- 8-pin connector with 8m (25ft) cable
- 8-pin connector with 15m (50ft) cable
- 8-pin connector with 25m (75ft) cable
- 8-pin connector with 30m (100ft) cable
- Other lengths

Accessories

- Mounting bracket
- Dummy plug for 1/2-20UNF
- Dummy plug for M18x1.5
- Drill kit for 1/2-20UNF
- Drill kit for M18x1.5
- Cleaning kit for 1/2-20UNF
- Cleaning kit for M18x1.5
- Fixing pen clip
- Autozero pen

Thermocouple for WE2 model

- Type "J" (153mm - 6" stem)

CON300
CON307

C08WLS
C15WLS
C25WLS
C30WLS
E08WLS
E15WLS
E25WLS
E30WLS
consult factory

SF18
SC12
SC18
KF12
KF18
CT12
CT18
PKIT309
PKIT312

TTER 601

Cable color code 6 wires		Cable color code 8 wires	
Conn.	Wire	Conn.	Wire
A	Red	A	White
B	Black	B	Red
C	White	C	Green
D	Green	D	Black
E	Blue	E	Blue
F	Orange	F	Orange
		G	n.c.
		H	n.c.

ORDER CODE

W - - - - - - - - - - 000

Autocompensation (*)	SP
Standard	-

(*) available for ranges > to 100bar
 (*) not available for WE3 version

OUTPUT SIGNAL	
4...20mA	E

CONFIGURATION	
Rigid stem	0
Rigid stem + flexible	1
With thermocouple	2
Exposed capillary	3

CONNECTOR	
Standard	
6 pin	6
8 pin	8

ACCURACY CLASS	
0.25% FSO (ranges ≥ 100 bar/1500 psi)	H
0.5% FSO	M

RANGE			
bar		psi	
35	B35U	500	P05C
50	B05D	750	P75D
70	B07D	1000	P01M
100	B01C	1500	P15C
200	B02C	3000	P03M
350	B35D	5000	P05M
500	B05C	7500	P75C
700	B07C	10000	P10M
1000	B01M	15000	P15M

000= Standard version
 Special or customized versions available on request

E	External autozero
-	Magnetic autozero

FLEXIBLE LENGTH (mm / inches) (*)		
Standard (WE0)		
0	none	
Standard (WE1, WE2)		
D	457mm	18"
E	610mm	24"
F	760mm	30"
Standard (WE3)		
L	711mm	28"
Available on request		
A	76mm	3"
B	152mm	6"
C	300mm	12"

RIGID STEM LENGTH (mm / inches) (*)		
Standard (WE0, WE1, WE2)		
4	153mm	6"
5	318mm	12.5"
Standard (WE3)		
0	none	
Available on request		
1	38mm	1.5"
2	50mm	2"
3	76mm	3"
6	350mm	14"
7	400mm	16"
8	456mm	18"

(*) max combined stem/flexible length is 914mm - 36"

THREAD	
Standard	
1	1/2 - 20 UNF
4	M18 x 1.5

Examples

WE2-6-M-B07C-1-4-D-000
 Melt pressure transmitter with type "J" thermocouple, 4...20mA output, 6-pin connector, 1/2-20UNF thread, 700 bar full scale, 0,5% accuracy class, 153 mm (6") rigid stem, 457mm (18") flexible capillary.

WSPM0-6-M-P03M-1-4-0-000
 Melt pressure transmitter autocompensated version, rigid stem, 4...20mA output, 6-pin connector, 1/2-20UNF thread, 3000 psi full scale, 0,5% accuracy class, 153 mm (6") rigid stem.

Sensors are manufactured in compliance with:
 - EMC compatibility directive
 - RoHS directive

Electrical installation requirements and Conformity certificate are available on our web site: www.gefran.com

GEFRAN reserves the right to make any kind of design or functional modification at any moment without prior notice.

GEFRAN spa
 via Sebina, 74
 25050 PROVAGLIO D'ISEO (BS) - ITALIA
 tel. 0309888.1 - fax. 0309839063
 Internet: <http://www.gefran.com>



Manual Revisions

Revision	Page/Chapter	Update description
Rev.11.18	Ch.2	Definition of Code updated according to M-series PLS Version 09Oct2018.
Rev.1.19	Ch10	Filter asy 825653, new drawing and BOM.
Rev.2.19	Ch.5	V6 Touch: Pump status icons added to Pump Overview screen.
	Ch. 11	V6 Profinet-Kit 121151 replaced with 121436.
Rev.3.19	Ch.11	New schematics.
Rev.10.19	Ch.9	Gear pump repair kit 103151 updated.
Rev.2.20	-	Manual new design.
Rev.3.20	Ch. 11	New schematics 820863S, 820948S, 821067R, 821070R.
	Ch.3, 4, 9	Level control options updated according Configurator,
Rev.10.20	Ch.6.4	Filter replacement updated.
Rev.11.20	Ch.7	Description of fuse 112568 to 10AF and fuse 119975 to 12AF updated. PCBs illustration 823306 to 10AF and 12AF updated.
Rev.5.21	Ch.5.2	V6 Touch updated. New setting for Global Zone.
	Ch. 10	Pressure gauge 819685 replaced by 101175.
	Ch.11	New schematics 820863T, 820948T, 821067S, 821070S.
Rev.6.21	Ch. 11	New schematics 820863U, 820948T, 821067T, 821070T.
Rev.12.22	Ch.9	System Status Lights PN 104280 replaced by 116848.
	Ch.6.4	Filter replacement updated.
	Ch.10.3	Filter and Shutoff Asy, right-hand, PN 105968, Filter and Shutoff Asy, right-hand, high-temp, PN 804465, Filter and Shutoff Asy, left-hand, long, PN 105969, Filter and Shutoff Asy, left-hand, long, high-temp, PN 804948, added.
Rev.1.23	Ch.3.2	Specifications: Maximum operating temperatures of 218°C (425°F) added.
Rev.6.23	P.1	Manual language added.
	Ch. 1	Declaration of Conformity updated.
Rev.12.23	Ch.3.2.2	Specifications / Lid opening dimensions added.
	Ch.10.7	Drive Assemblies / Key 109226 replaced by 822569.

ITW Dynatec Service Parts and Technical Service:

AMERICAS	EUROPE, MIDDLE EAST & AFRICA	ASIA PACIFIC	
<p>ITW Dynatec 31 Volunteer Drive Hendersonville, TN 37075 USA Tel. +1.615.824.3634 info@itwdynatec.com service@itwdynatec.com</p>	<p>ITW Dynatec Industriestrasse 28 40822 Mettmann Germany Tel. +49.2104.915.0 info@itwdynatec.de service@itwdynatec.de</p>	<p>ITW Dynatec No. 2 Anzhi Street, SIP, Suzhou, 215122 China Tel. +86.512.6289.0620 info@itwdynatec.cn service@itwdynatec.cn</p>	<p>ITW Dynatec Tsukimura Building 5th Floor 26-11, Nishikamata 7-chome Ota-ku, Tokyo 144-0051, Japan Tel. +81.3.5703.5501 info@itwdynatec.co.jp service@itwdynatec.co.jp</p>