

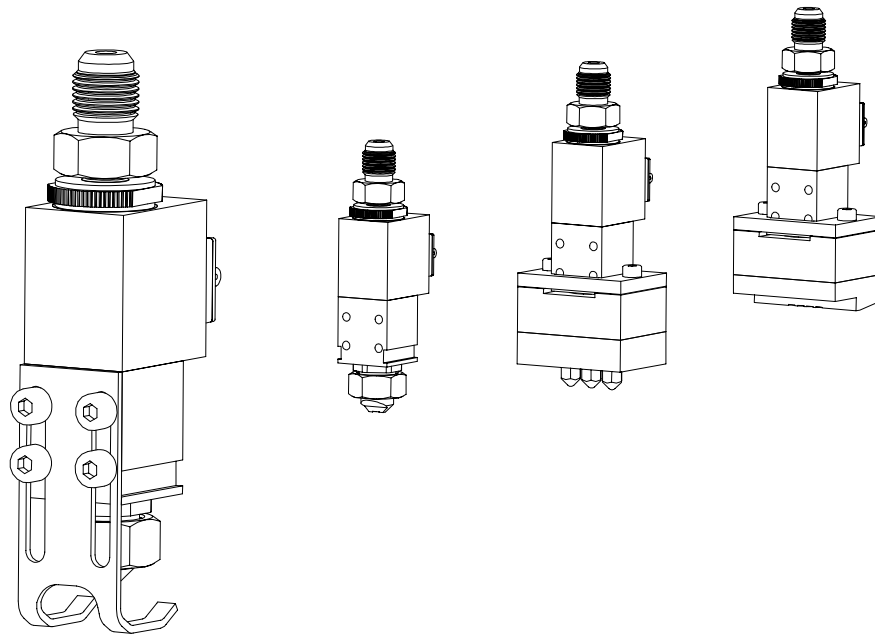

Adhesive Application Solutions • ISO 9001 Certified

DYNACOLD MINI COLD GLUE APPLICATOR OPERATIONS AND SERVICE MANUAL



IMPORTANT ! - READ ALL INSTRUCTIONS BEFORE OPERATING THIS EQUIPMENT

It is the customer's responsibility to have all operators and service personnel read and understand this information. Contact your ITW Dynatec customer service representative for additional copies.

NOTICE! Please be sure to include the serial number of your application system each time you order replacement parts and/or supplies. This will enable us to send you the correct items that you need.

ITW Dynatec Service Parts Direct Dial: 1-800-538-9540
ITW Dynatec Technical Service Direct Dial: 1-800-654-6711

ITW Dynatec
An Illinois Tool Works Company



Adhesive Application Systems

Table of Contents

Product description	1 - 1
Usage	1 - 1
Description	1 - 1
Technical data	1 - 1
Dimensions	1 - 3
Connection example	1 - 4
Installation	2 - 1
Install application head	2 - 1
Connect material hose	2 - 1
Connect the air hose for the shutter device (option)	2 - 2
Connect pattern control equipment	2 - 2
Installing the shutter device on the DynaCold Mini with seat nozzle	2 - 3
Installing the shutter device on the DynaCold Mini with flanged nozzle	2 - 3
Setup	3 - 1
Setup	3 - 1
Install nozzles	3 - 1
Install nozzle in DynaCold Mini with seat nozzle	3 - 1
Install nozzle in DynaCold Mini with flanged nozzle	3 - 2
Install nozzle in DynaCold Mini with contact nozzle	3 - 3
Install nozzle plate in DynaCold Mini with nozzle plate	3 - 3
Install nozzles in DynaCold Mini with nozzle plate and screw-in nozzles	3 - 4
Adjust the paper guide bracket (option)	3 - 5
Maintenance and servicing	4 - 1
Clean nozzles and nozzle plates	4 - 1
Purge the application head	4 - 1
Remove and replace the needle and needle seat	4 - 2
DynaCold Mini with seat nozzle	4 - 2
DynaCold Mini with flanged nozzle or contact nozzle	4 - 3
DynaCold Mini with nozzle plate	4 - 4
Clean the shutter device	4 - 5
Check and replace magnet coil	4 - 6
Troubleshooting	5 - 1

cont.

Replacement parts	6 - 1
DynaCold Mini with complete seat nozzle	6 - 1
DynaCold Mini with flanged or contact nozzle	6 - 2
DynaCold Mini for nozzle plate	6 - 3
DynaCold Mini application module	6 - 4
Seat nozzle repair kits	6 - 5
Flanged and contact nozzle repair kit	6 - 6
Flanged and contact nozzle repair kit (used with 14mm hex union nut)	6 - 7
Nozzle plate repair kit	6 - 8
Fitting for nozzle plate	6 - 9
Shutter Device for DynaCold Mini with seat and flanged nozzle (option)	6 - 10
Replacement parts	6 - 11
Paper guide bracket for DynaCold Mini with seat or flanged nozzle (option)	6 - 12
Accessories	7 - 1
Seat nozzles	7 - 1
Single orifice flanged nozzles for DynaCold Mini for flanged and contact nozzle	7 - 1
Single orifice contact nozzles for DynaCold Mini for flanged and contact nozzle	7 - 2
Dual orifice flanged nozzles for DynaCold Mini for flanged and contact nozzle	7 - 3
Dual orifice contact nozzle	7 - 4
Nozzle plates for contact application	7 - 5
Nozzle plates for screw-in nozzles	7 - 6
Screw-in nozzles	7 - 6
Nozzle cleaning kit	7 - 6
High-pressure material hoses	7 - 7
High pressure manifold	7 - 8
Shut-off unit for high and low pressure	7 - 8
Mounting for DynaCold Mini	7 - 9
DynaCold Mini initialization cable	7 - 9
Accessories for Shutter Device	7 - 9
Decommissioning, packaging and transportation	8 - 1
Temporary decommissioning	8 - 1
Permanent decommissioning and disposal	8 - 1
Manual Modifications	9 - 1

Product description

Usage

The DynaCold Mini application head is designed for applying mono and co-polymer synthetic resin adhesives. ITW Dynatec should be consulted prior to using any other materials.

Description

The DynaCold Mini series electric application heads are suitable for applying cold glue on various substrates. Depending on the design of the nozzle, the glue can be applied without contact or via nozzle contact with the substrate. Various gluing patterns: dots, stripes and beads are possible. DynaCold Mini with non-contact nozzles can be optionally equipped with shutter device, which prevents the glue in the nozzles from drying during periods of inactivity.

All models can be used in low and high-pressure systems. The modular design provides easy maintenance. The "straight through" flow with no dynamic seals assures reliability and durability. A large variety of nozzles and nozzle plates enables a multitude of applications. The 360° rotation of the magnetic coil offer the flexibility to meet varying installation requirements.

Technical data

	DynaCold Mini with seat nozzle	DynaCold Mini with flanged nozzle	DynaCold Mini with contact nozzle	DynaCold Mini with contact nozzle plate	DynaCold Mini with non-contact nozzle plate
Application type	Non-contact	Non-contact	Contact	Contact	Non-contact
Gluing pattern	bead	bead	stripe	stripe	bead
Design of the nozzle	Seat nozzle	Flanged nozzle	Flanged nozzle	Contact-Nozzle plate	Nozzle plate with screw-in nozzles
Number of orifices	1	1 - 2	1 - 2	1 - 10 *	1 - 5 *
Material viscosity	1 - 3000 mPas	1 - 3000 mPas	1 - 6000 mPas	1 - 6000 mPas	1 - 3000 mPas
Material pressure	Max. 30 bar				
Cycle rate	Max. 500/s				
Operating voltage	24 V DC + overexcitation				
Electrical output	9 W				
Noise emission	< 70 dB(A)				

* Special design also possible at the request of the customer.

DynaCold Mini with
seat nozzle

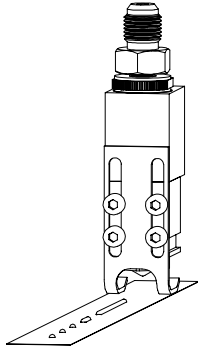

DynaCold Mini with
flanged nozzle

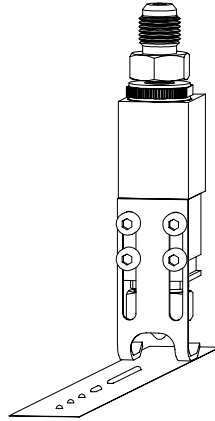

DynaCold Mini with
contact nozzle

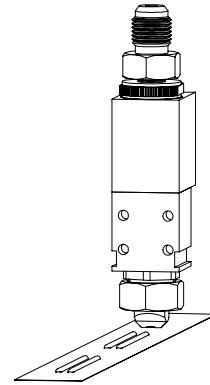

DynaCold Mini with
contact nozzle plate

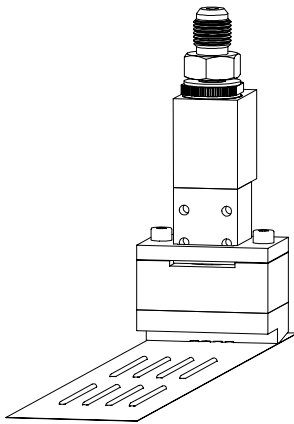

DynaCold Mini with non-
contact nozzle plate

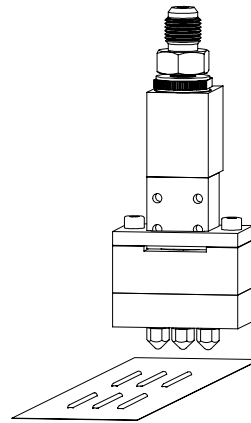

Dimensions

DynaCold Mini with flanged nozzle

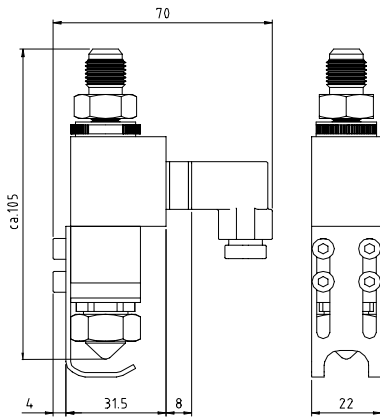

DynaCold Mini with flanged nozzle and shutter device

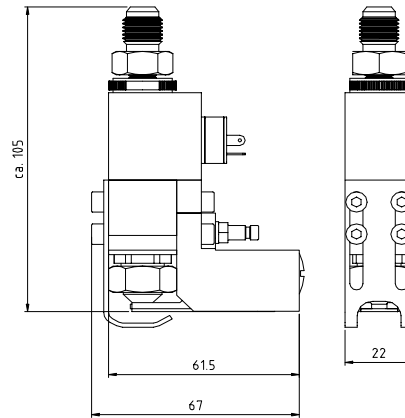

DynaCold Mini with seat nozzle

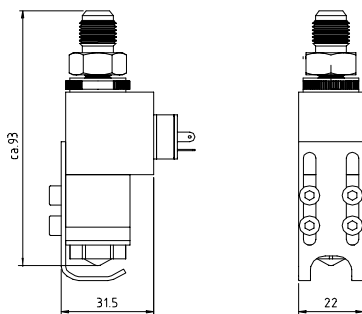

DynaCold Mini with contact nozzle

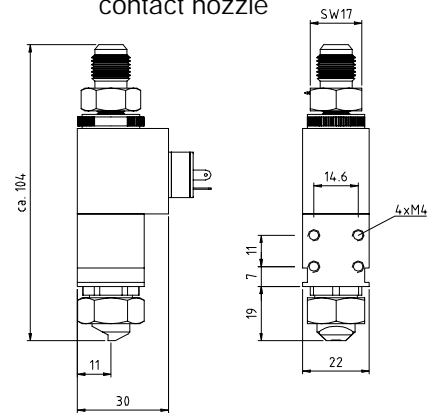

DynaCold Mini with nozzle plate

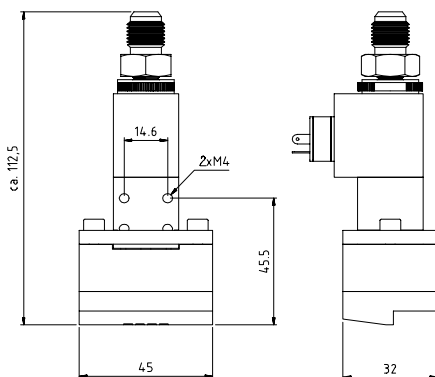

DynaCold Mini with nozzle plate and screw-in nozzles

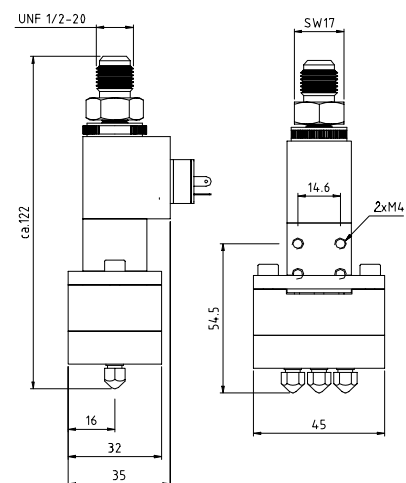

All dimensions in mm

Connection example

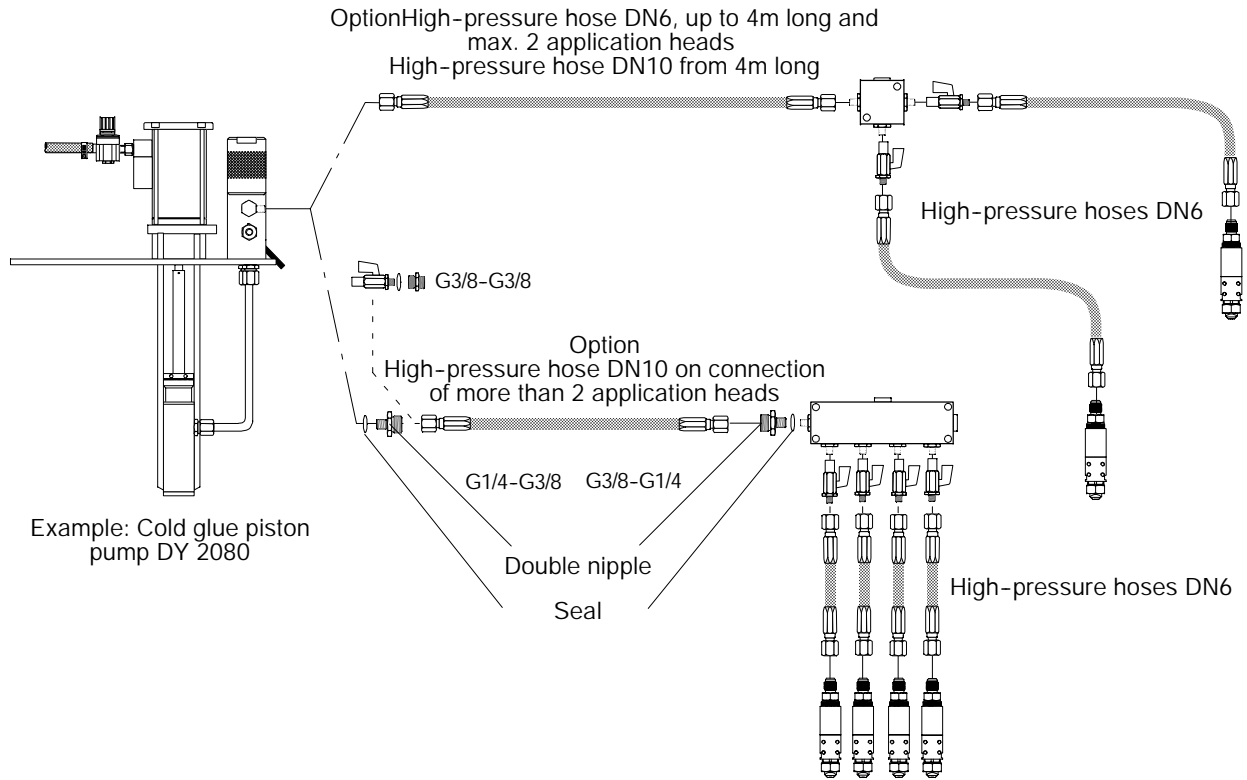

Installation



Warning!

The following work must only be performed by trained and authorized personnel. Observe the general safety instructions.

Install application head



Warning!

In order to obtain optimum operation, the application head must be installed securely and free of vibrations.

1. Fasten the application head to the ITW Dynatec mounting bracket (Art. No.: 73.50000.735) with four M 4 x 10 screws or with other M 4 fastening screws if a different mounting is used.

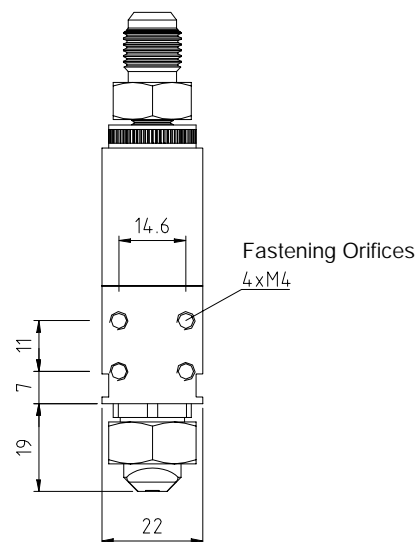

Connect material hose

1. Screw the threaded connection (1) of the material hose hand-tight onto the material hose connection (2).
2. Use an open-ended 17mm wrench to tighten the threaded connection of the material hose (1), and counterhold the material hose connection (2) with a second open-ended 17mm wrench. *Note: The material hose connection (2) must be counterheld under all circumstances, the applicator may otherwise become damaged.*

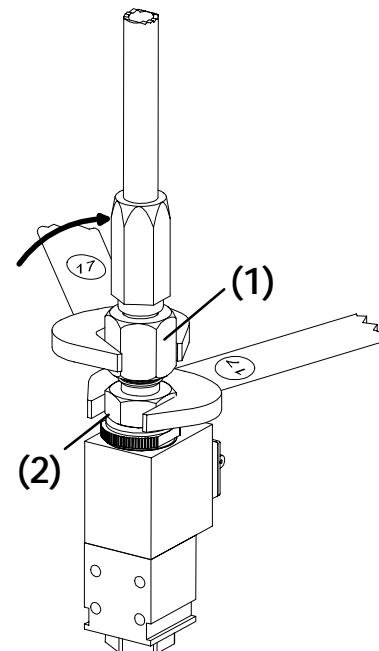

Connect the air hose for the shutter device (option)

1. Connect the air hose cap (1) to the shutter device plug-in nipple (2).
2. Connect the other end of the air hose to the pneumatic accessory for activating the shutter (see Chapter entitled "Accessories").

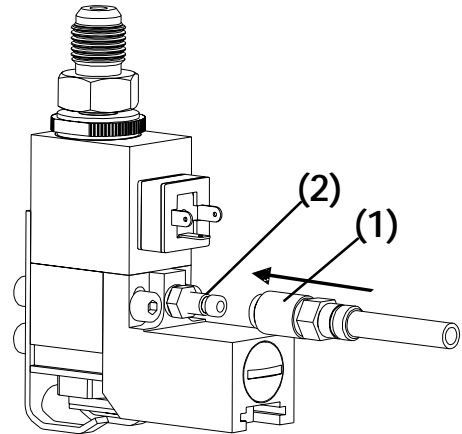

Connect pattern control equipment

1. Connect the pattern control system drive output cable to the DynaCold Mini application head. The application head-side of the factory-supplied drive output cable is equipped with a suitable plug.

If a connection cable without a pre-installed plug is used, proceed as follows:

1. Unscrew the plug's fastening screw (1) with a cross-point screwdriver, and remove the plug.
2. Unscrew the strain relief mechanism (2).
3. Pull the plug insert (3) out.
4. Insert a prepared initialization lead through the strain relief nut and through the cable passage.
5. Connect the leads according to the adjacent schematic.
6. Reassemble the electrical insert into the plug, and tighten the strain relief nut (2).
7. Place the plug onto the contacts, and secure it with the fastening screw (1).

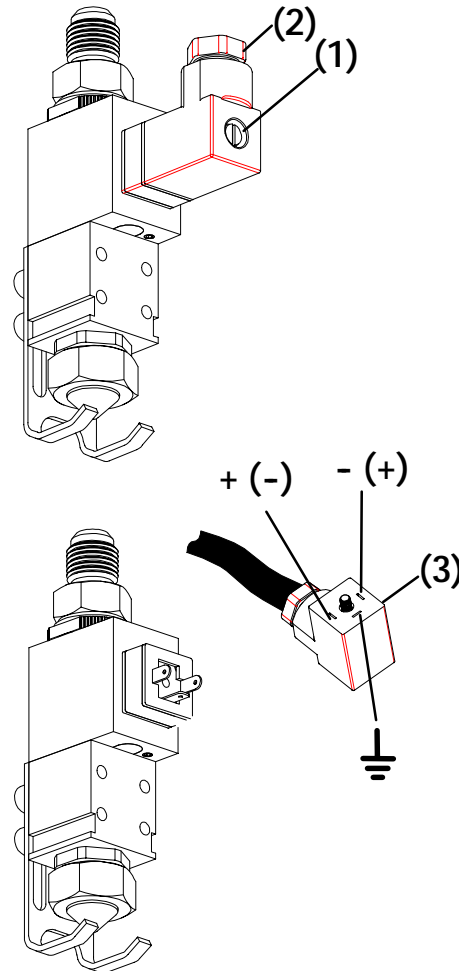

Installing the shutter device on the DynaCold Mini with seat nozzle

1. Position the shutter device (1) onto the axial conduit (2) beneath the magnet coil (3) and screw this on hand-tight with the two screws (4).

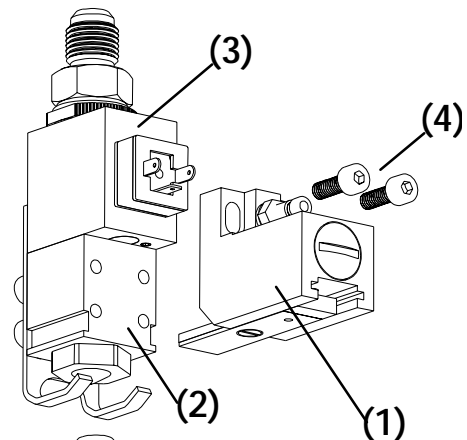

2. Push the shutter device against the stop edge of the magnet coil (3) and screw this on tightly with a 3mm hex wrench .

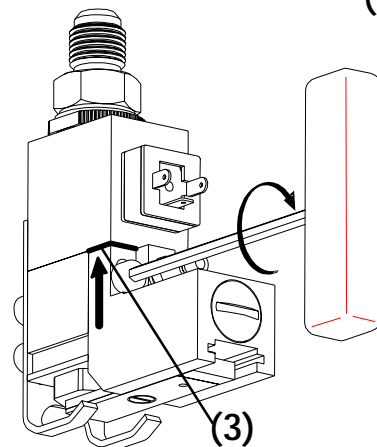

Installing the shutter device on the DynaCold Mini with flanged nozzle

1. Position the spacer (1) onto the axial conduit (2) beneath the magnet coil and screw this on tightly with the two M4x10 socket head screws (3) 3mm.

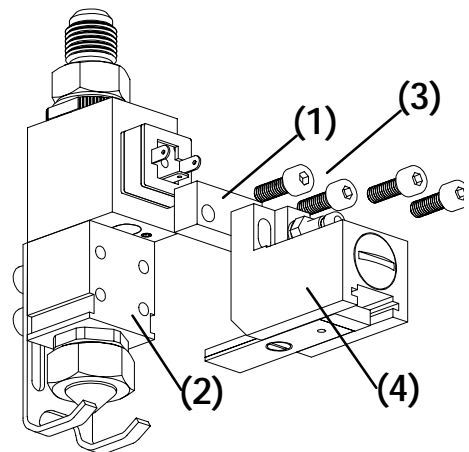

2. Position the shutter device (4) onto the axial conduit (2) beneath the spacer (1) and screw this on hand-tight with the two M4x10 socket head screws (3).

3. Push the shutter device against the stop edge of the spacer and screw this on tightly with a 3mm hex wrench.

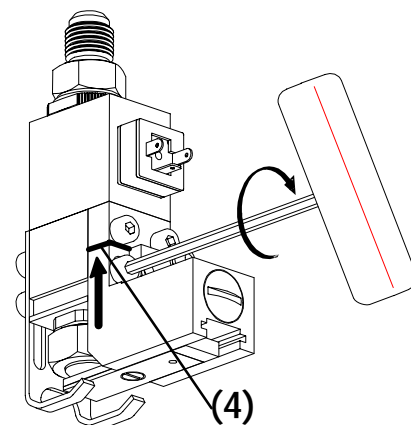

Setup



Warning!

The following work must only be performed by trained and authorized personnel. Observe the general safety instructions.

Setup

Note!

The system may contain production-related lubricants. In order to remove these, the application head must first be operated for a few minutes without nozzle(s). This avoids possible nozzle blockages.

1. Place a glue collecting vessel beneath the application head(s).



Warning, high pressure!

Danger of injury. The adhesive is under pressure. Wear eye protection.



2. Initiate a manual purge of the applicator via the pattern control equipment .
3. Allow the glue to flow until no further air bubbles or debris is visible.
4. Discontinue the manual purge.

Install nozzles

1. Render the application head pressure and voltage-free.

Install nozzle in DynaCold Mini with seat nozzle

In the case of this application head, the nozzle is already installed on delivery.

Note!

The nozzle and needle are provided as a matched set. Proper function can only be guaranteed in this manner. These components must therefore only be replaced as a set.

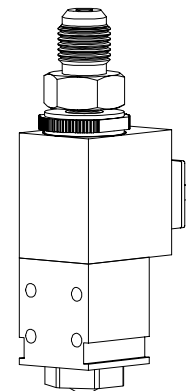

Install nozzle in DynaCold Mini with flanged nozzle

1. Unscrew the paper guide bracket device (if fitted) from the application head with a hex wrench 3 mm.
2. If shutter device is fitted:
Insert a hex wrench 2 mm or a round rod with a maximum diameter of 2 mm into the drill hole (1) of the slide (2) and press the locking pin in.
3. In this case, push the slide (2) backwards as shown in the figure. The slide can be left in this position or removed.
4. Position the nozzle (3) into the union nut (4) as shown in the Figure.
5. Screw the union nut (4) to the needle seat (5), and tighten it with an open-ended wrench 19 mm.
6. Insert the slide into the slot of the shutter device and push it into its original position until the locking pin audibly engages.

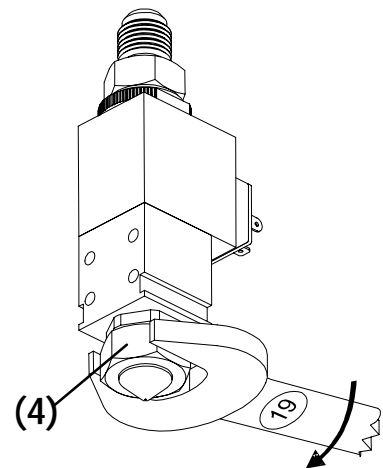
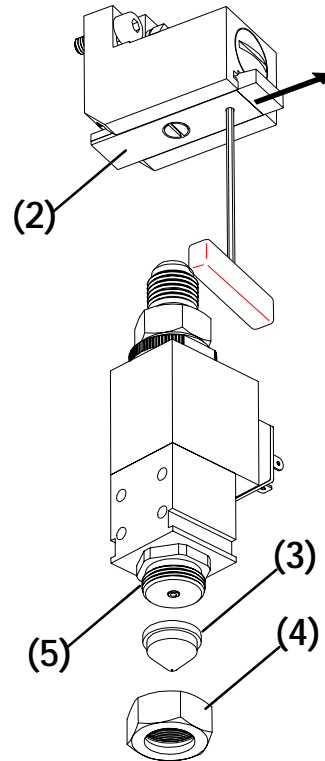
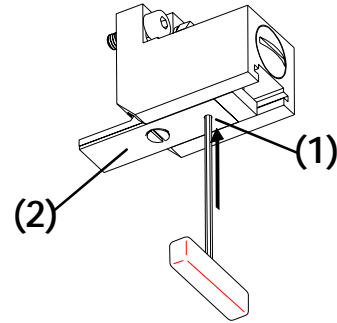

Install nozzle in DynaCold Mini with contact nozzle

1. Position the nozzle (1) into the union nut (2) as shown in the Figure.

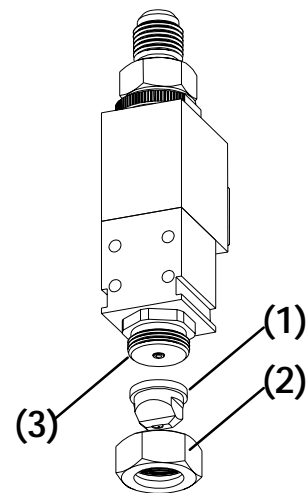

2. Screw the union nut (2) to the needle seat (3), and tighten this with an open-ended wrench 19 mm. In this case, align the nozzle at the face of the wrench with a open-ended wrench 10 mm.

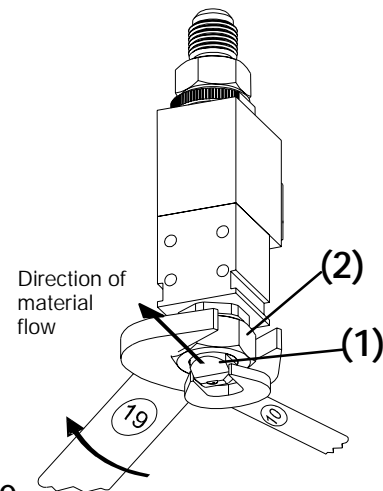

Install nozzle plate in DynaCold Mini with nozzle plate

1. Unscrew the four fastening screws of the nozzle plate (1) with a hex wrench 3 mm.
2. Position the nozzle plate (2) onto the nozzle plate mounting block (3).
3. Screw the nozzle plate (2) to the nozzle plate mounting block (3) with the four fastening screws (1).

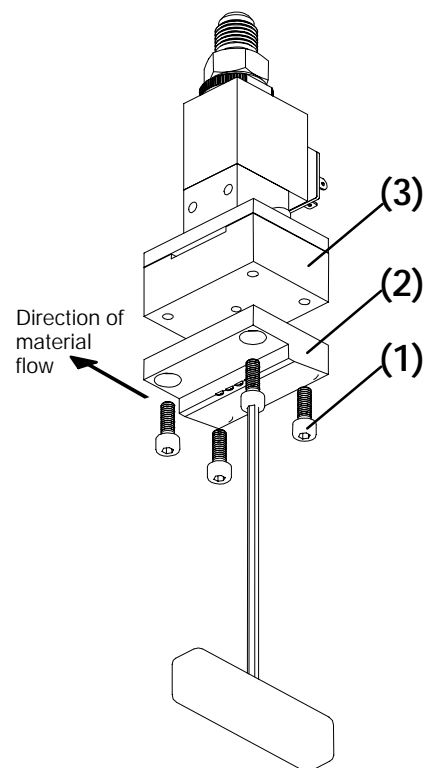

Install nozzles in DynaCold Mini with nozzle plate and screw-in nozzles

1. Unscrew the four fastening screws (1) from the fitting with a hex wrench 3 mm.
2. Position the nozzle plate (2) onto the nozzle plate mounting block (3).
3. Screw the nozzle plate (2) onto the mounting block (3) with the four hex screws.

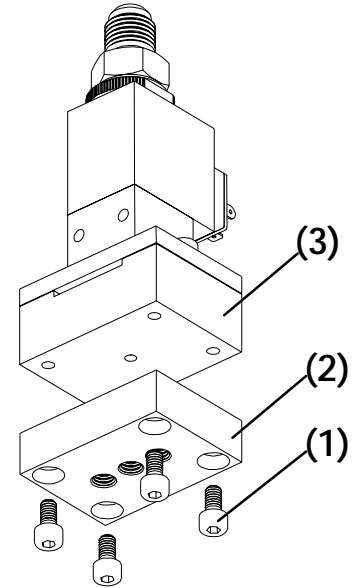

4. Install the screw-in nozzles (4) into the nozzle plate (2), and tighten these with an open-ended wrench 6 mm.

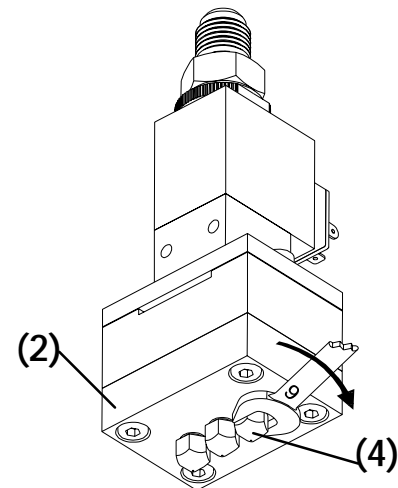

Adjust the paper guide bracket (option)

1. Adjust the application head with the desired nozzle distance to the substrate.
2. Loosen the four fastening screws (1) with a hex wrench 3 mm, and move the paper guide bracket to the desired position.

Note! *The substrate must be freely moveable beneath the paper guide bracket.*

3. Tighten the four fastening screws (1) with a hex wrench 3 mm.

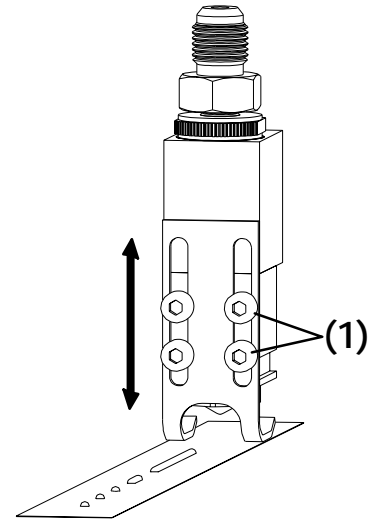

Maintenance and servicing



Warning!

The following work must only be performed by trained and authorized personnel. Observe the general safety instructions.

No fixed intervals of time are prescribed for DynaCold Mini application head maintenance. The frequency of the maintenance operations depends on the level of glue soiling and the duration of application head usage.

Clean nozzles and nozzle plates

1. Render the application head pressure and voltage-free. Secure it against reactivation. Loosen the electrical plug's central screw, and remove the plug from the applicator.
2. Remove the nozzle or nozzle plate. Proceed in the reverse sequence to that described in "Install nozzles" in Chapter 3
3. Clean the nozzle or nozzle plate with warm water. If severely soiled, warm water with a small amount of dishwashing liquid may be used. Nozzle cleaning kits are available from ITW Dynatec as an option .

Nozzle cleaning kit
see Chapter entitled "Accessories"

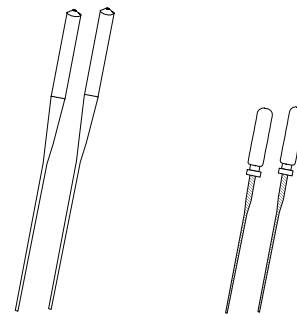

Purge the application head

Following a long period of operation, dirt may collect inside the application heads. This may lead to applicator malfunctions. The heads should therefore, be regularly rinsed with water.

1. Remove the glue from the glue delivery system and replace it with warm (not hot) water.
2. Unscrew the nozzle/nozzle plate from the application head.
3. Place a collecting vessel beneath the application head.
4. Switch the system on and allow the water to flow through until all glue is flushed from the system.
5. Switch the system off again once all of the water has flowed through.
6. Screw a clean nozzle/nozzle plate onto the application head. The system can now be operated with cold glue.

Remove and replace the needle and needle seat

Note! *The needle and needle seat or the needle and the seat nozzle are supplied as matched sets. Proper function can only be guaranteed in this manner. These components must therefore only be replaced as a set.*

1. Render the application head pressure and voltage-free. Secure it against reactivation. Unscrew the plug's central screw, and remove the electrical connector from the applicator.

DynaCold Mini with seat nozzle

1. Unscrew the paper guide bracket (if fitted) from the application head with an hex wrench 3 mm.
2. If a shutter device is fitted:
Insert an hex wrench 2 mm or a round rod with a maximum diameter of 2 mm into the drill hole (1) of the slide (2) and press the locking pin in.
3. In this case, push the slide (2) backwards as shown in the Figure. The slide can be left in this position or removed.
4. Unscrew the seat nozzle (3) from the axial conduit (4) with an open-ended wrench 17 mm.
5. Pull the needle/armature assembly and spring (5) out.

Note! *The seat nozzle and the needle/armature assembly are matched sets. Proper function can only be guaranteed in this manner. These components must therefore only be replaced as a set.*

6. Replace the seat nozzle (3), the O-ring (6) and the needle/armature assembly with spring (5).
7. Assembly is carried out in the reverse sequence.

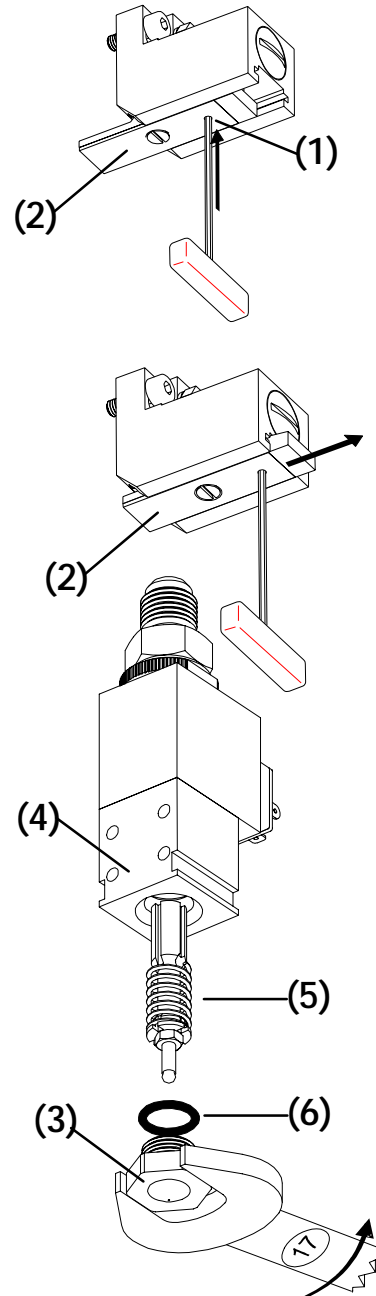

DynaCold Mini with flanged nozzle or contact nozzle

1. Unscrew the paper guide bracket (if fitted) from the application head with an hex wrench 3 mm.
2. If shutter device is fitted:
Insert an hex wrench 2 mm or a round rod with a maximum diameter of 2 mm into the drill hole (1) of the slide (2) and press the locking pin in.
3. In this case, push the slide (2) backwards as shown in the Figure. The slide can be left in this position or removed.

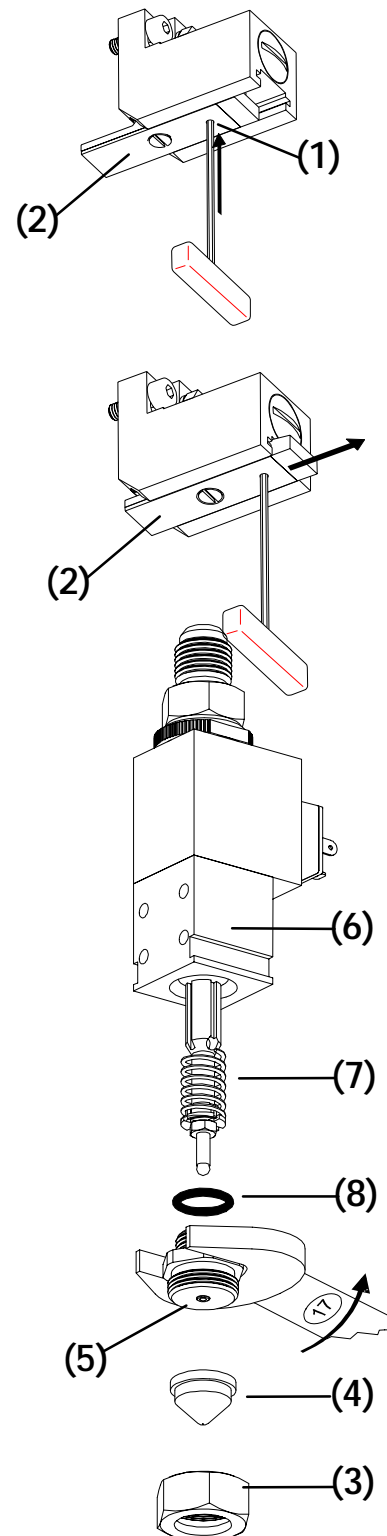

4. Unscrew the union nut (3) with an open-ended wrench 19 mm. Remove the union nut (3) with the nozzle (4).
5. Unscrew the needle seat (5) from the axial conduit (6) with an open-ended wrench 17 mm.
6. Pull the needle/armature assembly and spring (7) out.

Note! *The needle seat and needle armature assembly are a matched set. Proper function can only be guaranteed in this manner. These components must therefore only be replaced as a set.*

7. Replace the needle seat (5), the o-ring (8) and the needle/armature assembly and spring (7).
8. Assembly is carried out in the reverse sequence.

DynaCold Mini with nozzle plate

1. Remove the nozzle plate. Proceed in the reverse sequence to that described in "Install nozzle plate" in Chapter 2.
2. Unscrew the two locking plate (2) fastening screws (1) with an hex wrench 3 mm.
3. Remove the locking plate (2).
4. Pull the nozzle plate mounting block (3) downwards.

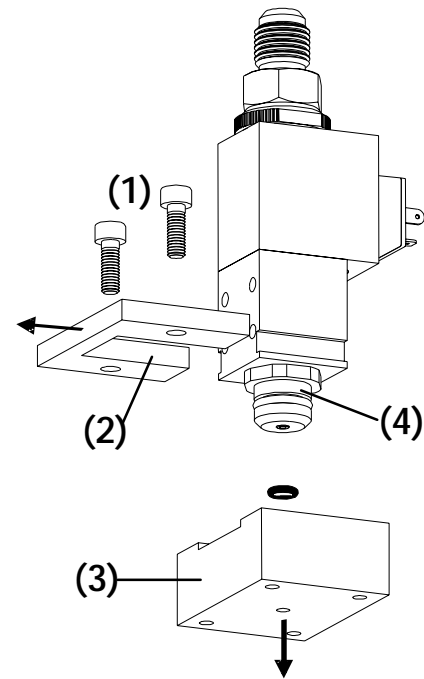

5. Unscrew the needle seat (4) from the axial conduit with an open-ended wrench 17 mm.
6. Pull out the needle/armature assembly and spring (5) .

Note! *The needle seat and the needle/armature assembly are a matched set. Proper function can only be guaranteed in this manner. These components must therefore only be replaced as a set.*

5. Replace the needle/armature assembly and spring (5), needle seat (4) and o-rings.
6. Assembly is carried out in the reverse sequence.

Note! *Grease the O-rings with silicone grease. This facilitates installation.*

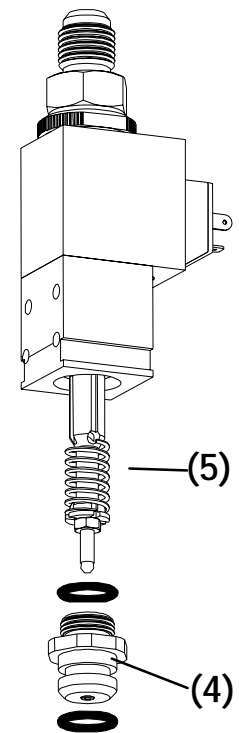

Clean the shutter device

1. Insert an hex wrench 2 mm or a round rod with a maximum diameter of 2 mm into the drill hole (1) of the slide (2) and press the locking pin in.
2. In this case, push the slide (2) backwards as shown in the Figure. The slide can be removed.
3. Clean the slide with warm water. If severely soiled, warm water with a small amount of dish-washing liquid may be used. The nozzle sealing can be removed and cleaned or replaced.
4. Assembly is carried out in the reverse sequence.

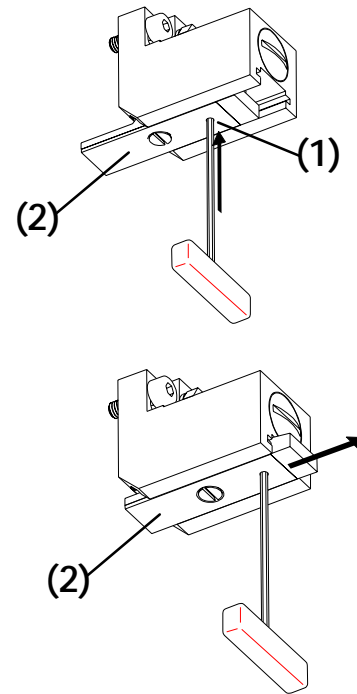

Check and replace magnet coil

1. Render the pump and the application head pressure and voltage-free. Secure these against reactivation. Unscrew the plug's central screw, and remove the electrical plug.
2. Measure the resistance of the coil. At room temperature, the electrical resistance should be $(63 \pm 3,5) \Omega$.
3. Replace the magnet coil if its resistance does not lie within this range.



Warning, high pressure!

Danger of injury. The adhesive is under pressure. Wear eye protection.

Note! *In certain cases, the material hose may still be under pressure. Particular caution should therefore be exercised!*

2. Unscrew the connection nipple (1) with an open-ended wrench 19 mm.
3. Unscrew the milled nut (2) by hand. If necessary, use an open-ended wrench 17 mm.
4. Pull the magnet coil (3) upwards.
5. Replace the magnet coil (3). It may be installed so either side the coil is up.
6. Assembly is carried out in the reverse sequence.

Note! *Do not overtighten the milled nut (2) as this may result in damage to the axial conduit. The magnet coil (3) is secured the axial conduit (4) with the milled nut.*

Note! *Top or bottom of coil may be reversed.*

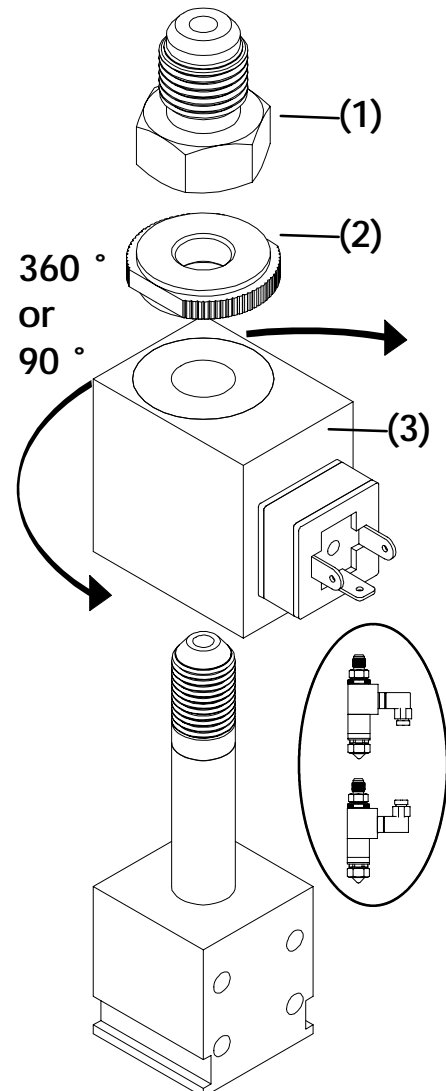
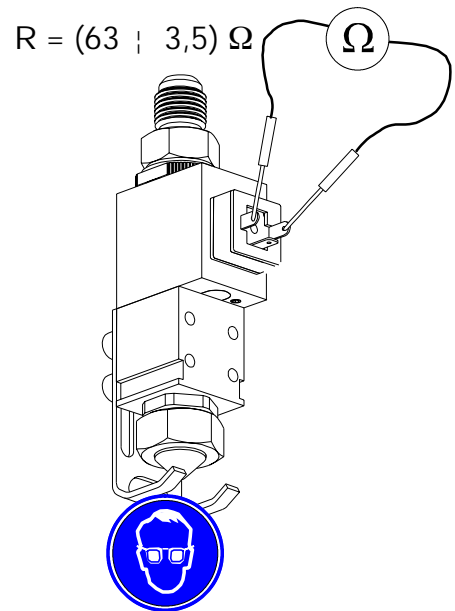

Troubleshooting

This Chapter contains a description of possible malfunctions, the causes of these malfunctions and possible solutions. Obvious defects such as mechanical damage or damaged electrical leads or pneumatic lines are not dealt with. These faults should be detected and repaired during the regular inspection of the system.

Check all electrical and pneumatic connections. Check whether the air pressure is set to proper operating values, and whether the proper supply voltage is available. Also check whether the glue reservoir contains glue.

Malfunction	Cause	Remedy
No glue flow	No glue in the tank	Fill glue tank
	Nozzle blocked	Clean nozzle
	Plug loose	Screw plug on securely
	Initialization voltage not available	Check pattern controll output for 170 V overexcitation
	Coil defective	Replace coil
	Material hose blocked	Rinse material hose and replace if necessary
Glue emerges from the nozzle when application head is closed	Dirt in the needle seat	Clean needle seat
	Needle seat worn out	Replace needle seat and needle
	Spring broken	Replace spring

Note! *The Chapter entitled Maintenance and Servicing contains instructions on how to remove and disassemble individual components.*

Replacement parts

DynaCold Mini with complete seat nozzle

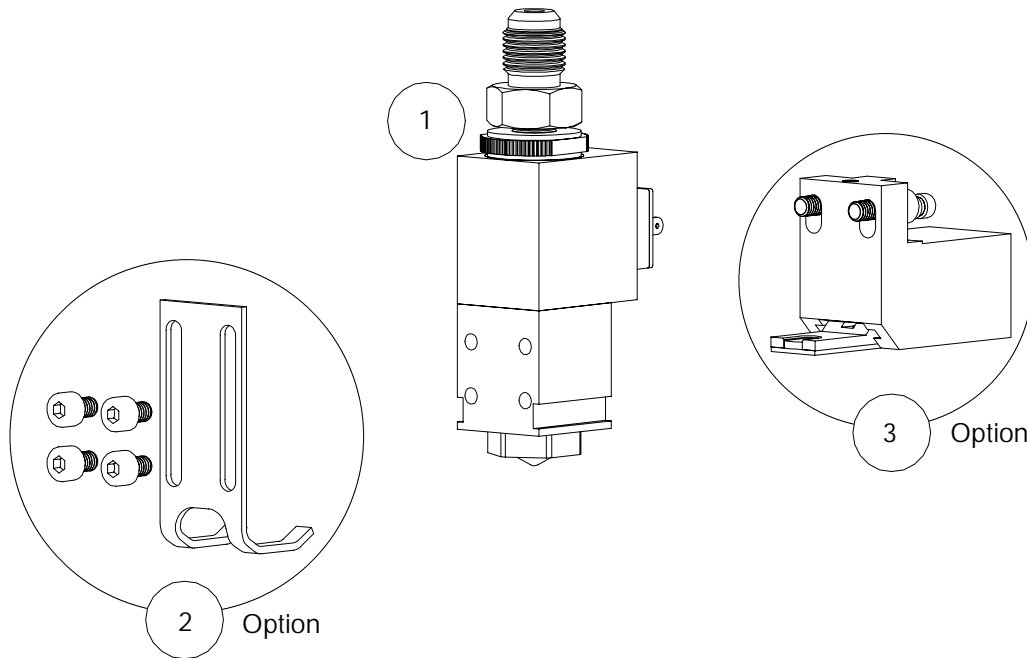

Item	Art. No.	Article
1	70.06304.725 or 108123	DynaCold Mini with seat nozzle Ø 0.25 mm, 1/2 UNF Fluid Ftg.
	108130	DynaCold Mini with seat nozzle Ø 0.25 mm, 1/8 NPT Fluid Ftg.
1	70.06304.730 or 108124	DynaCold Mini with seat nozzle Ø 0.30 mm, 1/2 UNF Fluid Ftg.
	108131	DynaCold Mini with seat nozzle Ø 0.30 mm, 1/8 NPT Fluid Ftg.
1	70.06304.740 or 108125	DynaCold Mini with seat nozzle Ø 0.40 mm, 1/2 UNF Fluid Ftg.
	108132	DynaCold Mini with seat nozzle Ø 0.40 mm, 1/8 NPT Fluid Ftg.
1	70.06304.750 or 180126	DynaCold Mini with seat nozzle Ø 0.50 mm, 1/2 UNF Fluid Ftg.
	108133	DynaCold Mini with seat nozzle Ø 0.50 mm, 1/8 NPT Fluid Ftg.
2	70.60000.702	Complete paper guide bracket (option)
3	70.06000.703	Complete shutter device (option)

DynaCold Mini with flanged or contact nozzle

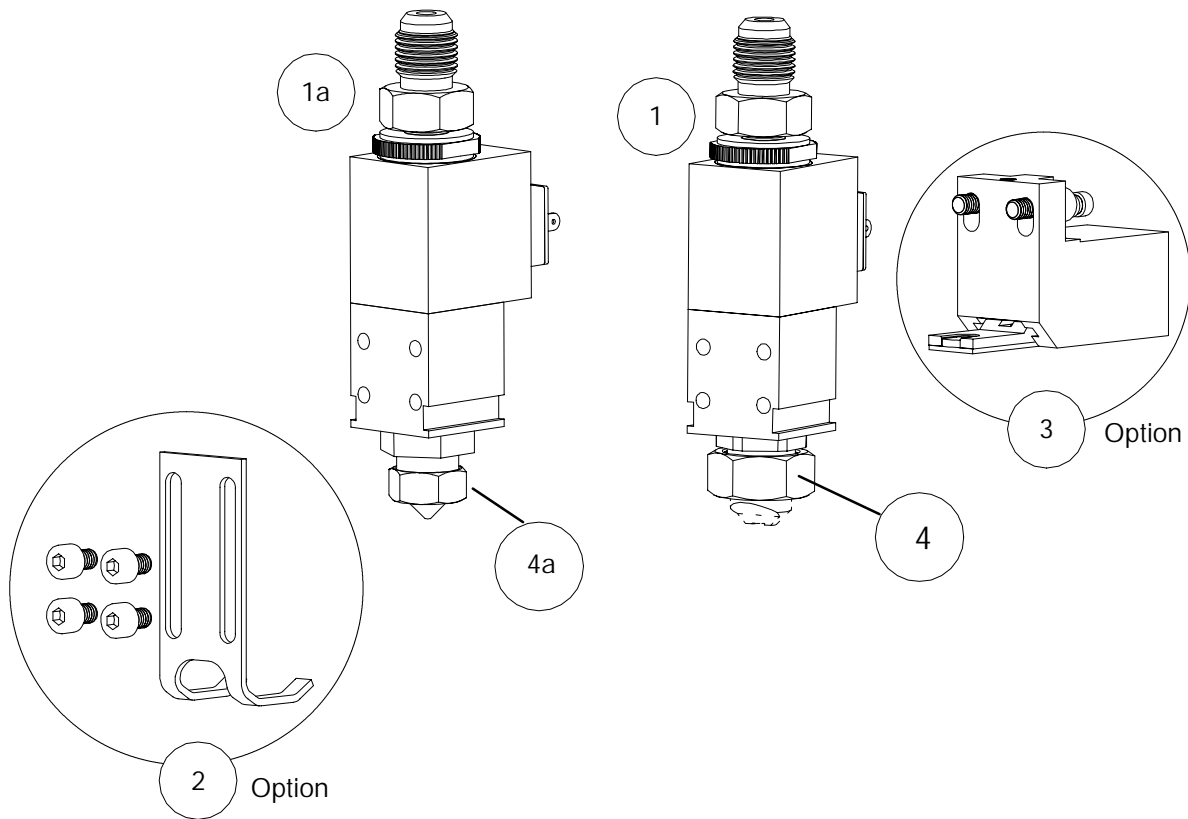

Item	Art. No.	Article
1	70.06304.701 or 108122	DynaCold Mini for flanged or contact nozzles using 19mm hex union nut (nozzles must be ordered separately. See Chapter titled Accessories)
1a	111158	DynaCold Mini for flanged nozzles using 14mm hex union nut (nozzles must be ordered separately, see chapter titled Accessories)
2	70.60000.702	Complete paper guide bracket (option for DynaCold Mini with flanged nozzle)
3	70.06000.703	Complete shutter device (option for DynaCold Mini with flanged nozzle)
4	70.00100.170	Union nut, 19mm hex
4a	75.00000.109	Union Nut, 14mm hex

DynaCold Mini for nozzle plate

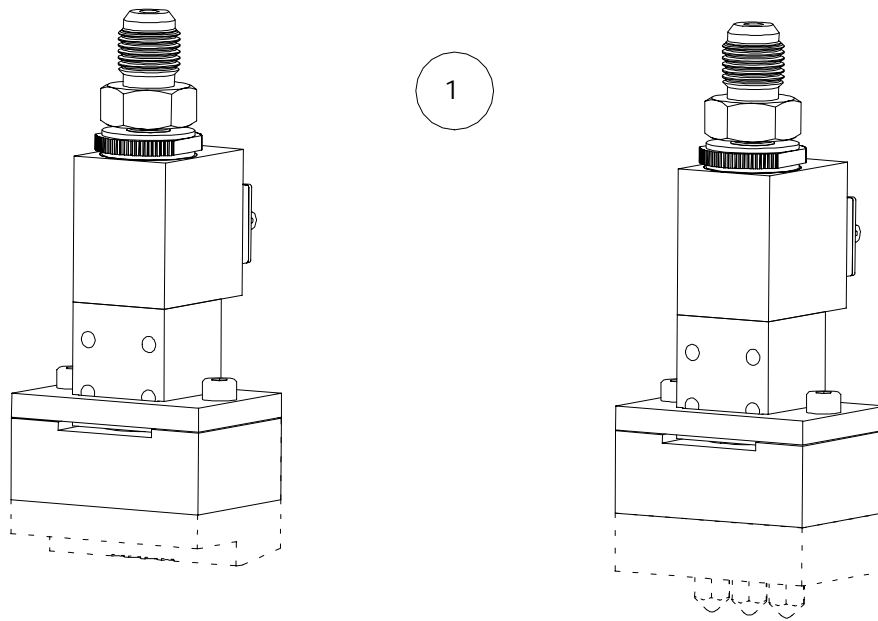

Item	Art. No.	Article
1	70.06304.702	DynaCold Mini for nozzle plate (nozzle plates must be ordered separately. See Chapter entitled Accessories.)

DynaCold Mini application module

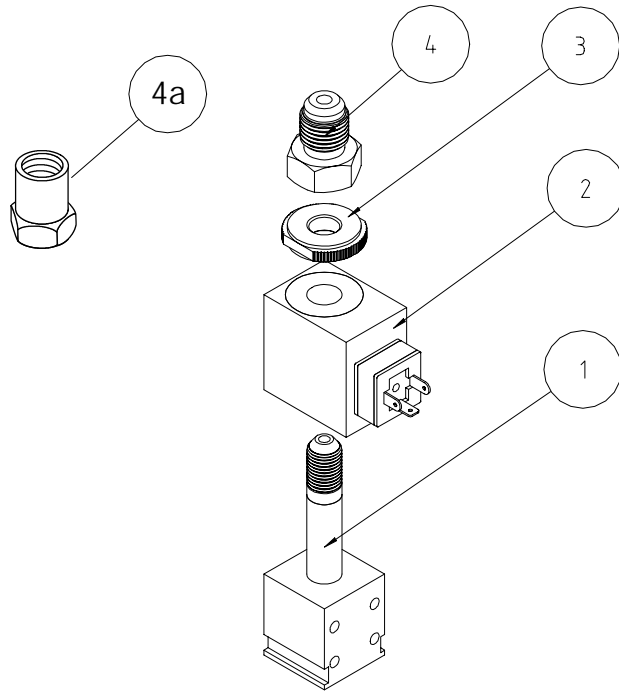

Item	Art. No.	Article		Quantity
	70.06000.701	Complete application module		1
1	70.04000.331	Axial conduit		1
2	05.54110.005	Magnet coil	A	1
3	70.04000.332	Milled nut		1
4	70.04000.341	Connection nipple, 1/2 UNF thread		1
4a	70.04000.342	Connection union, 1/8 NPT		1

Note! The spare parts marked with this symbol A are wear parts. In order to avoid longer down-times, we recommend that you keep a small stock of these wear parts.

Seat nozzle repair kits

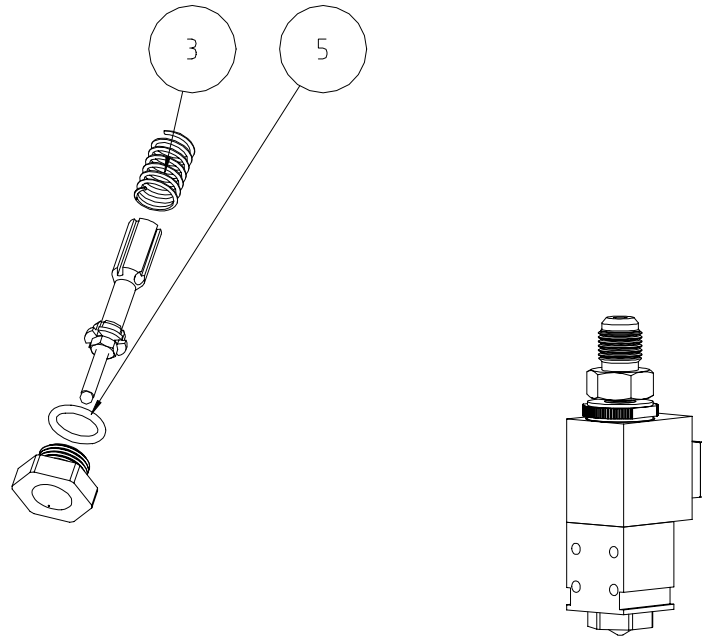

Item	Art. No.	Article		Quantity
	70.06000.725	Seat nozzle repair kit Ø 0.25 mm, complete	A*	1
	70.06000.730	Seat nozzle repair kit Ø 0.30 mm, complete	A*	1
	70.06000.740	Seat nozzle repair kit Ø 0.40 mm, complete	A*	1
	70.06000.750	Seat nozzle repair kit Ø 0.50 mm, complete	A*	1
3	04.11009.098	Pressure spring	A	1
5	06.00925.012	O-ring	A	1

* According to the nozzle diameter which is used.

Note! *The spare parts marked with this symbol A are wear parts. In order to avoid longer down-times, we recommend that you keep a small stock of these wear parts.*

Note! *Repair kits include all items shown. Needle/armature assembly and seat nozzles only sold in matched sets.*

Flanged and contact nozzle repair kit (used with 19mm hex union nut)

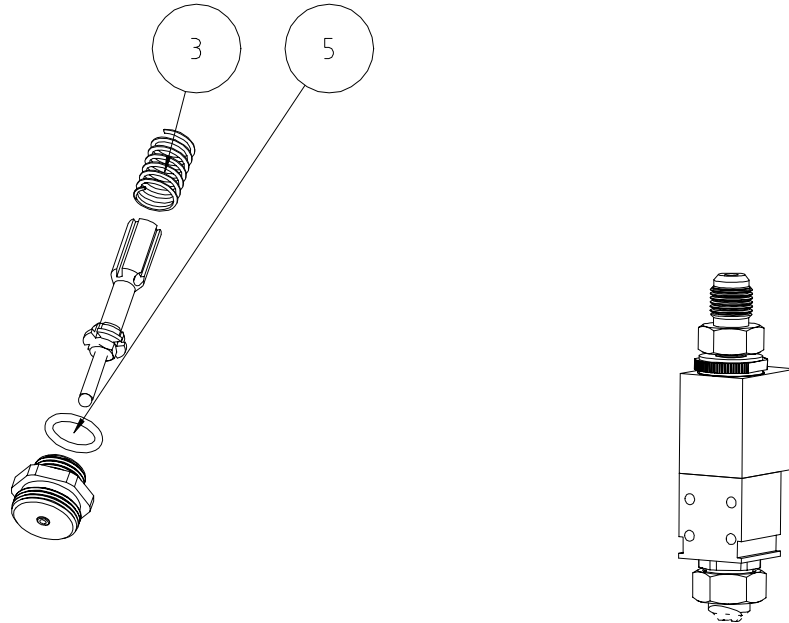

Item	Art. No.	Article		Quantity
	70.06000.704	Flanged and contact nozzle repair kit (incl. item 3 and 5)	A	1
3	04.11009.098	Pressure spring	A	1
5	06.00925.012	O-ring	A	1

Flanged and contact nozzle repair kit (used with 14mm hex union nut)

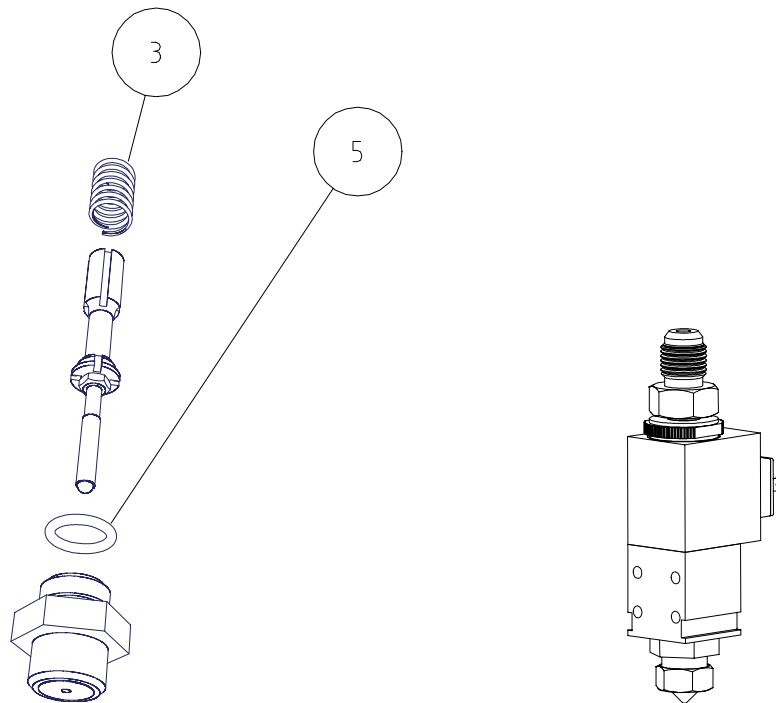

Item	Art. No.	Article		Quantity
	70.06000.707	Flanged nozzle repair kit (incl. item 3 and 5)	A	1
	04.11009.098	Pressure Spring	A	1
	06.00925.012	O-ring	A	1

Note! The spare parts marked with this symbol A are wear parts. In order to avoid longer down-times, we recommend that you keep a small stock of these wear parts.

Note! Repair kits include all items shown.
Needle/armature assembly and seat nozzles only sold in matched sets.

Nozzle plate repair kit

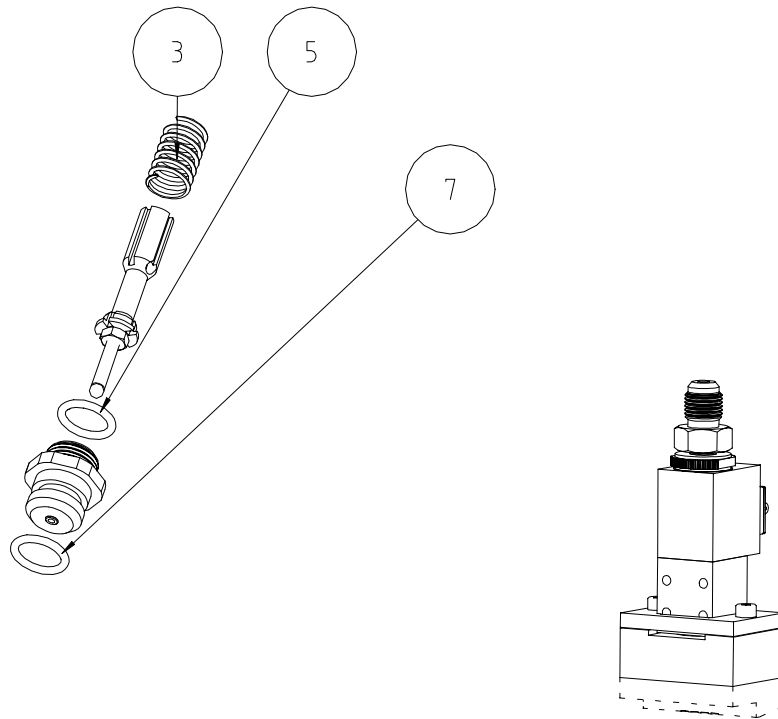

Item	Art. No.	Article		Quantity
	70.06000.705	Nozzle plate repair kit (incl. item. 3, 5 and 7)	A	1
3	04.11009.098	Pressure spring	A	1
5	06.00925.012	O-ring	A	1
7	06.01000.001	O-ring	A	1

Note! *The spare parts marked with this symbol A are wear parts. In order to avoid longer down-times, we recommend that you keep a small stock of these wear parts.*

Note! *Repair kits include all items shown. Needle/armature assembly and seat nozzles only sold in matched sets.*

Fitting for nozzle plate

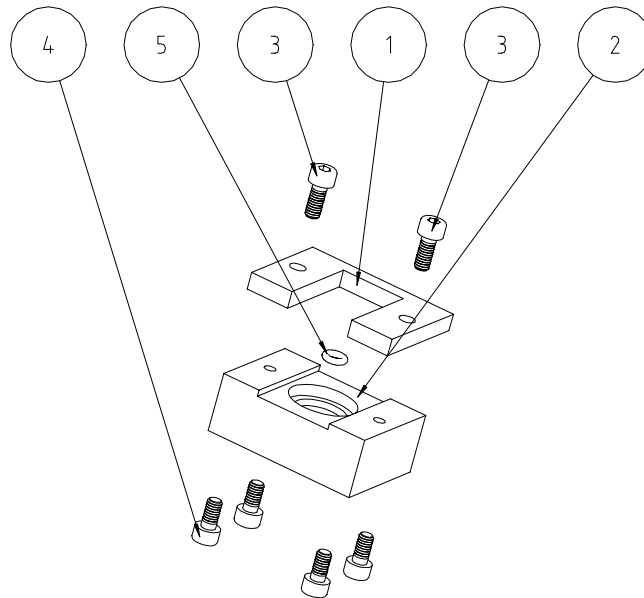

Item	Art. No.	Article		Quantity
	70.06000.706	Fitting for nozzle plate, complete		1
1	06.04000.136	Locking plate		1
2	06.04000.137	Nozzle plate mounting block		1
3	00.10410.912	Socket head cap screw M4x10 SST		2
4	00.10408.912	Socket head cap screw M4x8 SST		4
5	06.00368.007	O-ring	A	1

Note! *The spare parts marked with this symbol A are wear parts. In order to avoid longer down-times, we recommend that you keep a small stock of these wear parts.*

Shutter Device for DynaCold Mini with seat and flanged nozzle (option)

Item	Art. No.	Article		Quantity
	70.06000.703	Shutter Device, complete		1
1	70.06000.713	Complete slide		1
a	70.04000.336	Slide		1
b	70.04000.339	Pressure plate		1
c	70.04000.131	Gasket	A	1
d	00.10304.963	Countersunk screw		1
e	03.21506.325	Parallel pin		4
2	70.04000.335	Housing		1
3	70.04000.337	Piston		1
4	70.04000.338	Piston		1
6	04.10325.041	Pressure spring		1
7	07.00500.106	Connection nipple M 5		1
7a	340-012	Connection nipple, 1/8 tube (must be ordered separately).		1
8	05.93070.001	Closure cap Pg 7		1
9	04.11080.159	Pressure spring	A	1
12	06.00607.010	O-ring	A	1
13	00.10412.912	Socket head cap screw		4
14	00.80404.913	Set screw		1
15	70.04000.344	Spacer block		1

Note! *The spare parts marked with this symbol A are wear parts. In order to avoid longer down-times, we recommend that you keep a small stock of these wear parts.*

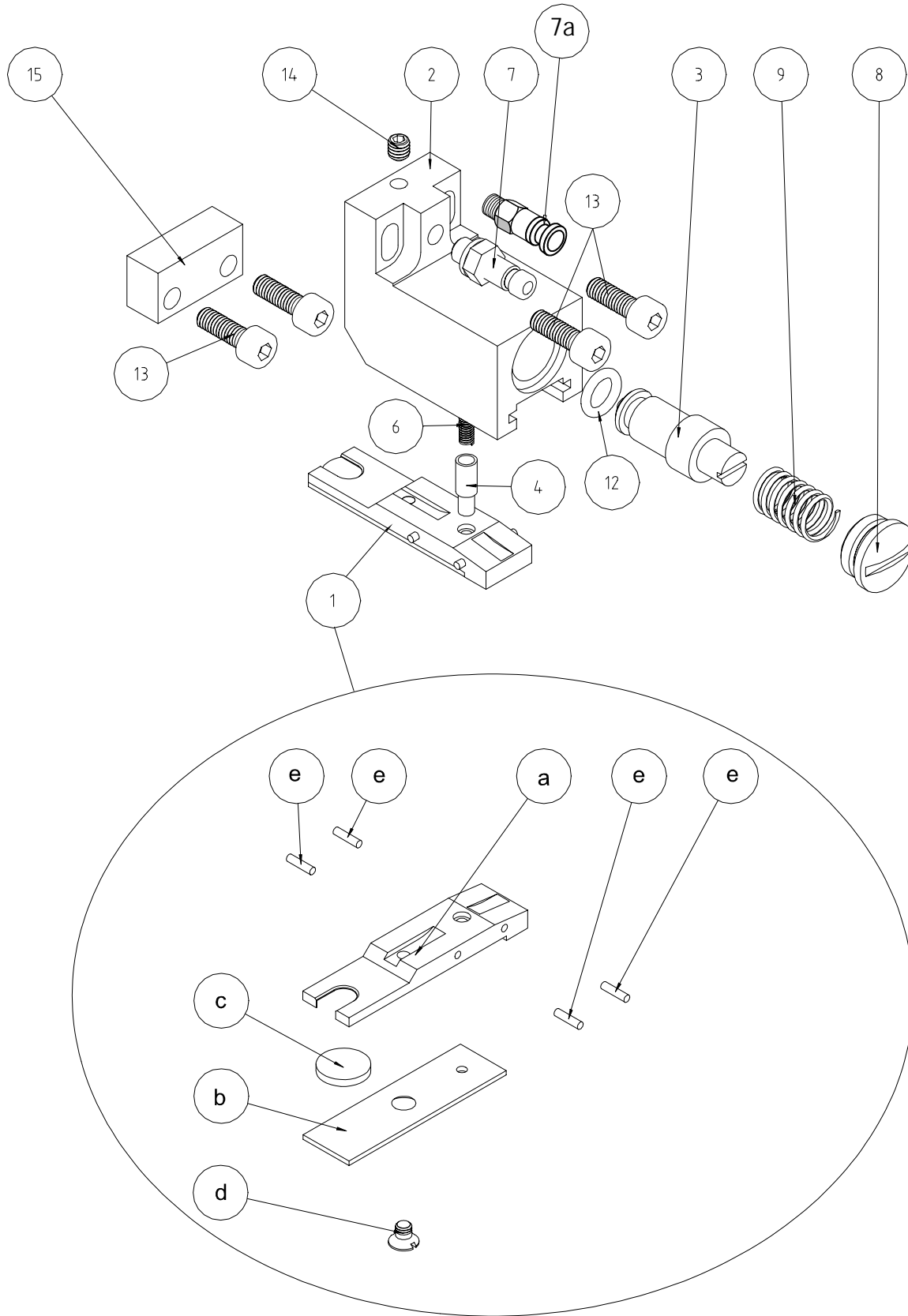

Paper guide bracket for DynaCold Mini with seat or flanged nozzle (option)

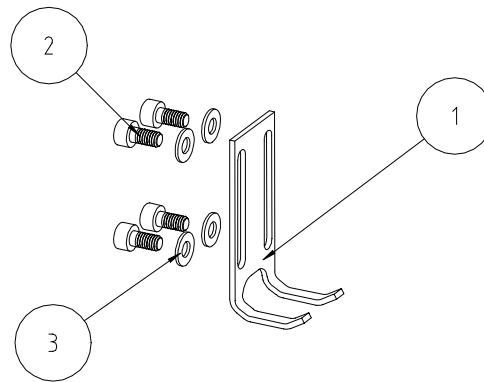

Item	Art. No.	Article	Quantity
	70.06000.702	Paper guide bracket, complete	1
1	70.06000.101	Paper guide bracket	1
2	00.10408.912	Socket head cap screw M4x10 SST	4
3	02.00430.125	Washer, Flat M4 SST	4

Accessories

Seat nozzles

Note! *The nozzle and the needle/armature assembly are matched sets. Proper function can only be guaranteed in this manner. These components should therefore only be replaced as a set.*

Seat nozzle repair kits can be found in Chapter 5, Replacement Parts.

Single orifice flanged nozzles for DynaCold Mini with 19mm hex union nut.

Part No.	Description	
91.00020.102	Flanged nozzle Ø 0.20 mm	
91.00025.102	Flanged nozzle Ø 0.25 mm	
91.00030.102	Flanged nozzle Ø 0.30 mm	
91.00035.102	Flanged nozzle Ø 0.35 mm	
91.00040.102	Flanged nozzle Ø 0.40 mm	
91.00045.102	Flanged nozzle Ø 0.45 mm	
91.00050.102	Flanged nozzle Ø 0.50 mm	
91.00060.102	Flanged nozzle Ø 0.60 mm	
91.00070.102	Flanged nozzle Ø 0.70 mm	
91.00080.102	Flanged nozzle Ø 0.80 mm	
91.00100.102	Flanged nozzle Ø 1.00 mm	
91.00120.102	Flanged nozzle Ø 1.30 mm	
91.00150.102	Flanged nozzle Ø 1.50 mm	

Single orifice flanged nozzles for DynaCold Mini with 14mm hex union nut (used only with PN 111158)

Part No.	Description	
91.01030.120	Flanged nozzle Ø 0.30 mm	
91.01040.120	Flanged nozzle Ø 0.40 mm	
91.01050.120	Flanged nozzle Ø 0.50 mm	

Single orifice contact nozzles for DynaCold Mini with 19mm hex union nut (10mm width)

Art. No.	Article	
93.02030.108	Contact nozzle (0.2 mm groove depth) Ø 0.30 mm	
93.02035.108	Contact nozzle (0.2 mm groove depth) Ø 0.35 mm	
93.02040.108	Contact nozzle (0.2 mm groove depth) Ø 0.40 mm	
93.02045.108	Contact nozzle (0.2 mm groove depth) Ø 0.45 mm	
93.02050.108	Contact nozzle (0.2 mm groove depth) Ø 0.50 mm	
93.02060.108	Contact nozzle (0.2 mm groove depth) Ø 0.60 mm	
93.02070.108	Contact nozzle (0.2 mm groove depth) Ø 0.70 mm	
93.02090.108	Contact nozzle (0.2 mm groove depth) Ø 1.00 mm	
93.06030.108	Contact nozzle (0.6 mm groove depth) Ø 0.30 mm	
93.06035.108	Contact nozzle (0.6 mm groove depth) Ø 0.35 mm	
93.06040.108	Contact nozzle (0.6 mm groove depth) Ø 0.40 mm	
93.06045.108	Contact nozzle (0.6 mm groove depth) Ø 0.45 mm	
93.06050.108	Contact nozzle (0.6 mm groove depth) Ø 0.50 mm	
93.06060.108	Contact nozzle (0.6 mm groove depth) Ø 0.60 mm	
93.06070.108	Contact nozzle (0.6 mm groove depth) Ø 0.70 mm	
93.06090.108	Contact nozzle (0.6 mm groove depth) Ø 1.00 mm	

Single orifice contact nozzles for DynaCold Mini with 19mm hex union nut (6mm width)

Part No.	Description	
93.02030.106	Contact nozzle (0.20 mm groove Depth) Ø 0.30mm	
93.02035.106	Contact nozzle (0.20 mm groove Depth) Ø 0.35mm	
93.02040.106	Contact nozzle (0.20 mm groove Depth) Ø 0.40mm	
93.02050.106	Contact nozzle (0.20 mm groove Depth) Ø 0.50mm	

Dual orifice flanged nozzles for DynaCold Mini with 19mm hex union nut.

Art.-Nr.	Article	Ø	(
92.00330.101	Dual orifice flanged nozzle	0.30 mm	30°
92.00335.101	Dual orifice flanged nozzle	0.35 mm	30°
92.00340.101	Dual orifice flanged nozzle	0.40 mm	30°
92.00345.101	Dual orifice flanged nozzle	0.45 mm	30°
92.00350.101	Dual orifice flanged nozzle	0.50 mm	30°
92.00360.101	Dual orifice flanged nozzle	0.60 mm	30°
92.00370.101	Dual orifice flanged nozzle	0.70 mm	30°
Art. No.	Article	Ø	(
92.00430.101	Dual orifice flanged nozzle	0.30 mm	45°
92.00435.101	Dual orifice flanged nozzle	0.35 mm	45°
92.00440.101	Dual orifice flanged nozzle	0.40 mm	45°
92.00445.101	Dual orifice flanged nozzle	0.45 mm	45°
92.00450.101	Dual orifice flanged nozzle	0.50 mm	45°
92.00460.101	Dual orifice flanged nozzle	0.60 mm	45°
92.00470.101	Dual orifice flanged nozzle	0.70 mm	45°
92.00480.101	Dual orifice flanged nozzle	0.80 mm	45°
92.00490.101	Dual orifice flanged nozzle	0.90 mm	45°
Art. No.	Article	Ø	(
92.00630.101	Dual orifice flanged nozzle	0.30 mm	60°
92.00635.101	Dual orifice flanged nozzle	0.35 mm	60°
92.00640.101	Dual orifice flanged nozzle	0.40 mm	60°
92.00645.101	Dual orifice flanged nozzle	0.45 mm	60°
92.00650.101	Dual orifice flanged nozzle	0.50 mm	60°
92.00660.101	Dual orifice flanged nozzle	0.60 mm	60°
92.00670.101	Dual orifice flanged nozzle	0.70 mm	60°

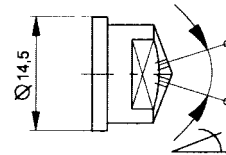

Dual orifice contact nozzle for DynaCold Mini with 19mm hex union nut.

Art.-Nr.	Article	Ø	On center separation	Groove depth
94.02330.101	Dual orifice contact nozzle	0.30 mm	3 mm	0,2 mm
94.02335.101	Dual orifice contact nozzle	0.35 mm	3 mm	0,2 mm
94.02340.101	Dual orifice contact nozzle	0.40 mm	3 mm	0,2 mm
94.02360.101	Dual orifice contact nozzle	0.60 mm	3 mm	0,2 mm
94.02365.101	Dual orifice contact nozzle	0.65 mm	3 mm	0,2 mm
Art.-Nr.	Article	Ø		
94.02830.101	Dual orifice contact nozzle	0.30 mm	8 mm	0,2 mm
94.02840.101	Dual orifice contact nozzle	0.40 mm	8 mm	0,2 mm

Nozzle plates for contact application

The nozzle plates are individually manufactured according to your wishes. The basic area of the nozzle plate is 45 x 32 mm. The number and the diameter of the drill holes may vary. The following drawing shows these options:

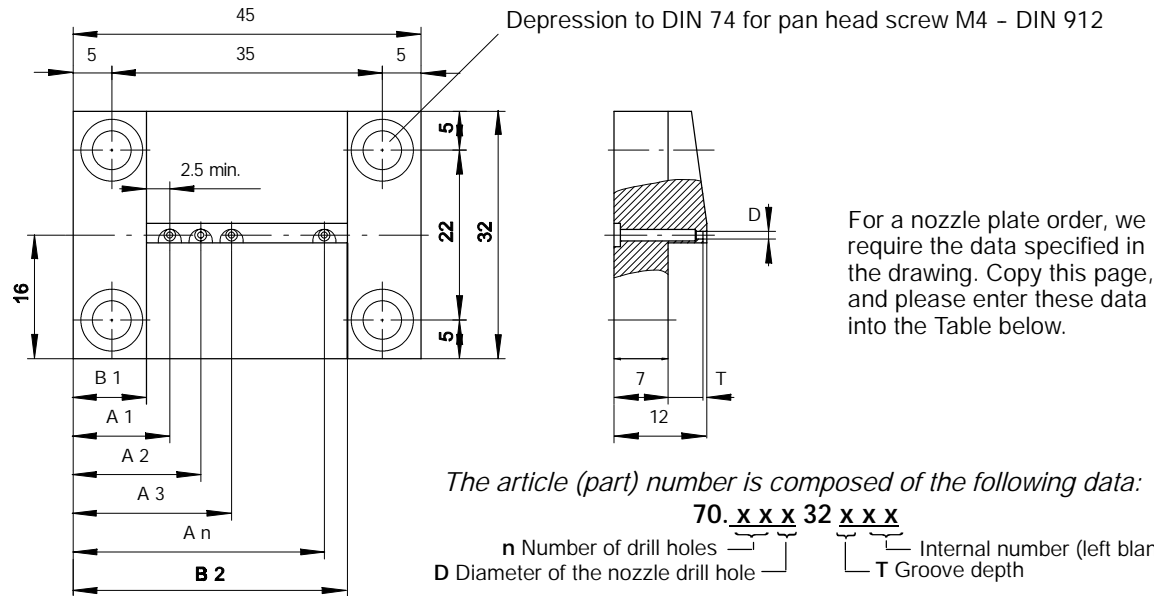

		Nozzle plate 1	Nozzle plate 2	Nozzle plate 3	Nozzle plate 4	Nozzle plate 5
Number of drill holes	n					
Diameter of the drill hole	D					
Groove depth	T					
Distance 1 to tear edge	B1					
Distance 2 to tear edge	B2					
Distance to drill hole 1	A1					
Distance to drill hole 2	A2					
Distance to drill hole 3	A3					
Distance to drill hole 4	A4					
Distance to drill hole 5	A5					
Distance to drill hole 6	A6					
Distance to drill hole 7	A7					
Distance to drill hole 8	A8					
Distance to drill hole 9	A9					
Distance to drill hole 10	A10					
Distance to drill hole 11	A11					
Article number						

Nozzle plates for screw-in nozzles

The nozzle plates are individually manufactured according to your wishes. The basic area of the nozzle plate is 45 x 32 mm. The number of screw-in nozzles may vary.

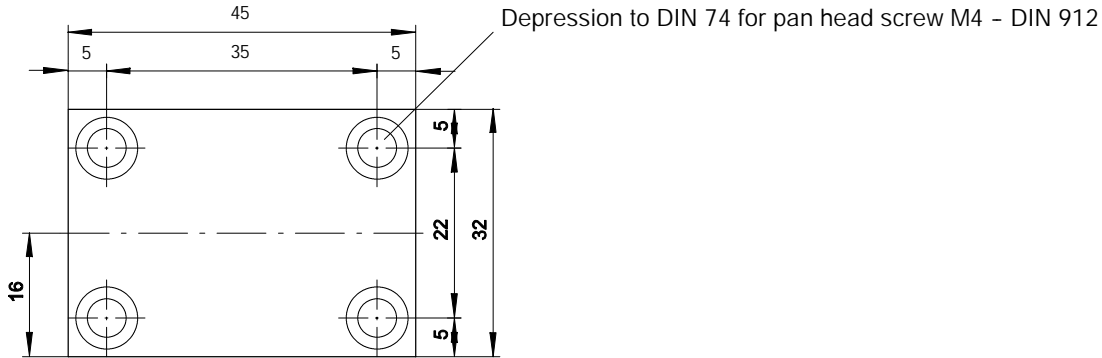

Screw-in nozzles

Art. No.	Article
91.60000.125	Screw-in nozzle SS \varnothing 0.25 mm
91.60000.103	Screw-in nozzle SS \varnothing 0.30 mm
91.60000.113	Screw-in nozzle SS \varnothing 0.35 mm
91.60000.104	Screw-in nozzle SS \varnothing 0.40 mm
91.60000.105	Screw-in nozzle SS \varnothing 0.50 mm
91.60000.106	Screw-in nozzle SS \varnothing 0.60 mm
91.60000.109	Screw-in nozzle SS \varnothing 0.70 mm
91.60000.108	Screw-in nozzle SS \varnothing 0.80 mm
91.60000.107	Screw-in nozzle SS \varnothing 1.00 mm
91.60000.110	Screw-in nozzle SS \varnothing 1.50 mm



A detailed illustration of a screw-in nozzle, showing its threaded top section and the nozzle tip.

Nozzle cleaning kit

Item	Art. No.	Article	Quantity
1	09.39000.001	Universal nozzle cleaning kit up to \varnothing 0.40 mm	12 units
2	09.39000.015	Nozzle cleaning kit \varnothing 0.15 mm	6 units
2	09.39000.020	Nozzle cleaning kit \varnothing 0.20 mm	6 units
2	09.39000.025	Nozzle cleaning kit \varnothing 0.25 mm	6 units
2	09.39000.030	Nozzle cleaning kit \varnothing 0.30 mm	6 units
2	09.39000.035	Nozzle cleaning kit \varnothing 0.35 mm	6 units

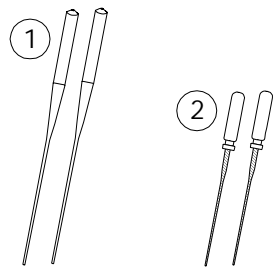
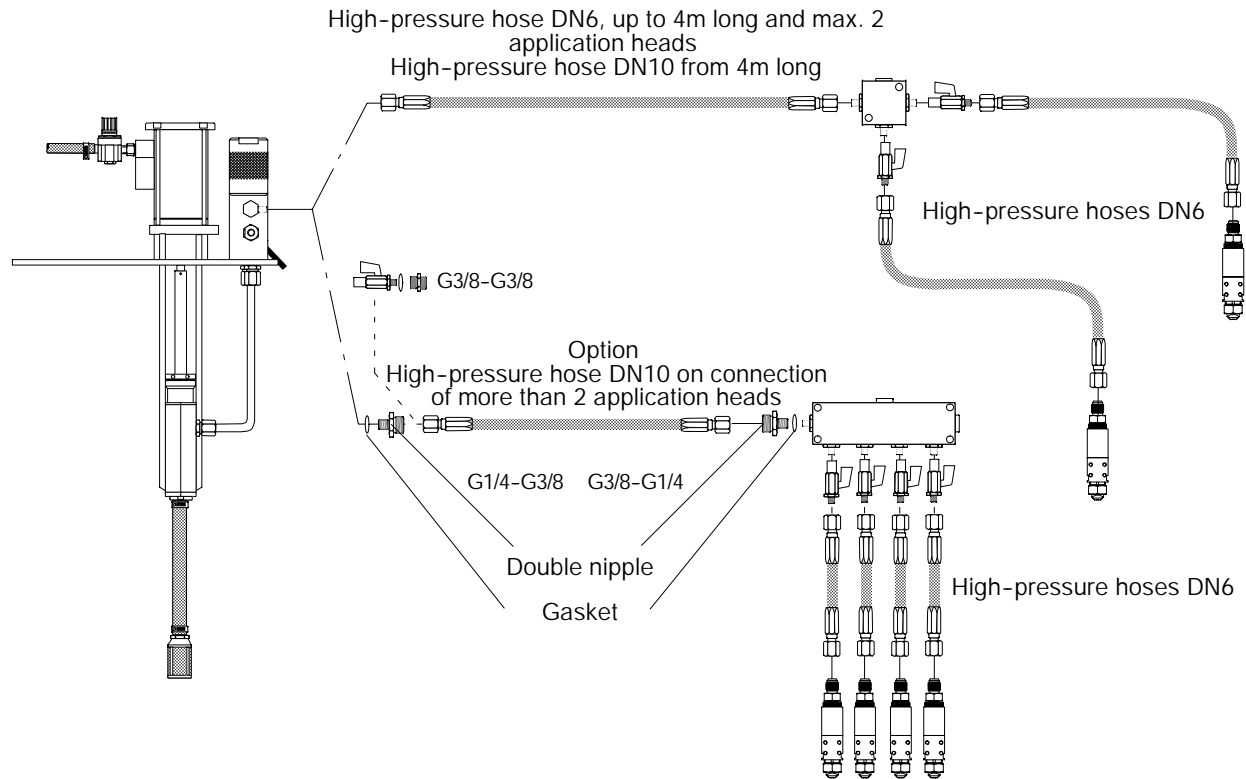

Illustration of nozzle cleaning kits. Kit 1 consists of two long, thin cleaning rods. Kit 2 consists of two shorter cleaning rods with a different tip design.

High-pressure material hoses



High-pressure hoses DN6

Length	Art. No.
0.2	30.00002.727
0.5	30.00002.729
1.0	30.00002.730
2.0	30.00002.721
3.0	30.00002.731
4.0	30.00002.722
5.0	30.00002.732
6.0	30.00002.728
7.0	30.00002.736
8.0	30.00002.726
10.0	30.00002.733
15.0	30.00002.735

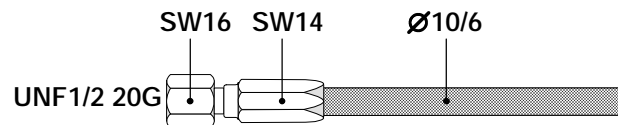

High-pressure hoses DN10

Length	Art. No.
3.0	30.00002.743
4.0	30.00002.744
5.0	30.00002.745
6.0	30.00002.746
10.0	30.00002.750

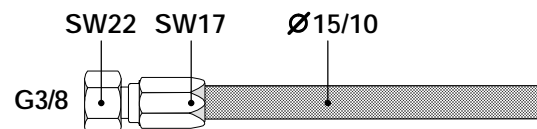

For this hose, two double nipples G1/4-G3/8 Art. No. 07.01438.101 and two gaskets Art. No. 02.11350.001 are required.

High pressure manifold

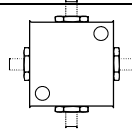
Number of application heads	Art. No.	
2	30.00002.752	
3	30.00002.753	

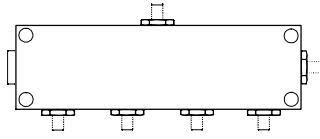
Number of application heads	Art. No.	
4	30.00002.754	
5	30.00002.755	
6	30.00002.756	

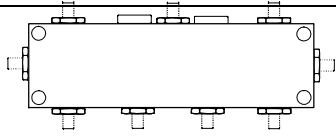
Number of application heads	Art. No.	
7	30.00002.757	
8	30.00002.758	

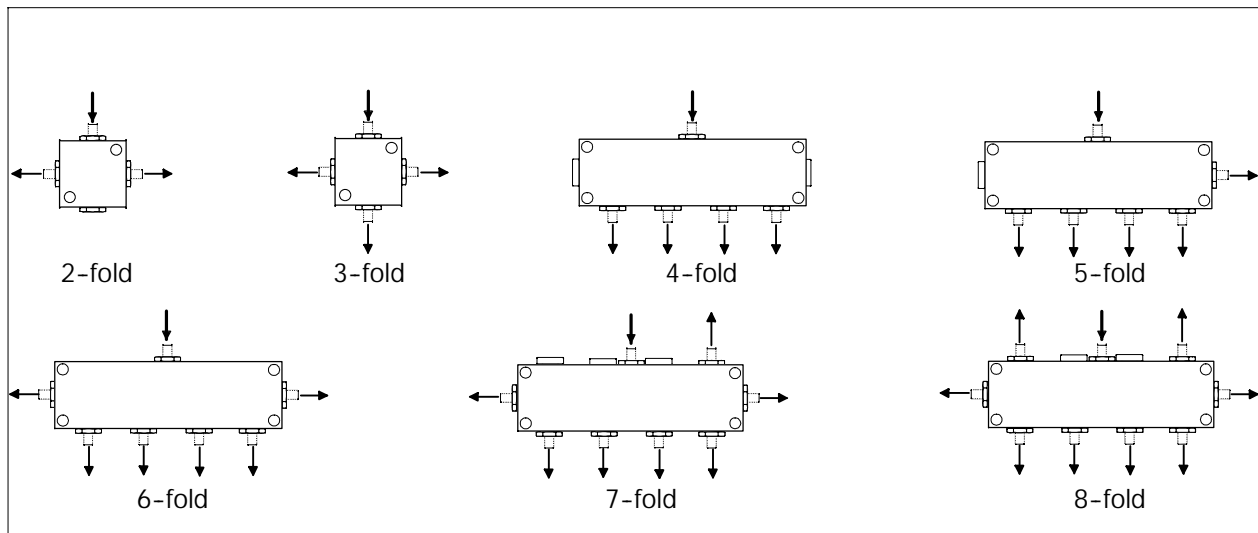

Shut-off unit for high and low pressure

Art. No.	Article	
30.00004.701	Complete shut-off unit	

Mounting for DynaCold Mini

Item	Art. No.	Article
	73.50000.735	Fast Adjust Bracket, with M8-1.25 thread for sensor mounting.
	73.50000.736	Fast Adjust Bracket with /16-24 thread for sensor mounting.

DynaCold Mini initialization cable

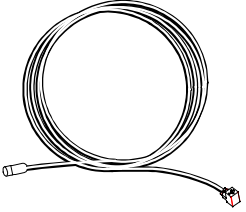
Art. No.	Article	
05.02104.616	Complete DynaCold Mini initialization cable, 5 m	
05.02104.618	Complete DynaCold Mini initialization cable, 10 m	

Accessories for Shutter Device

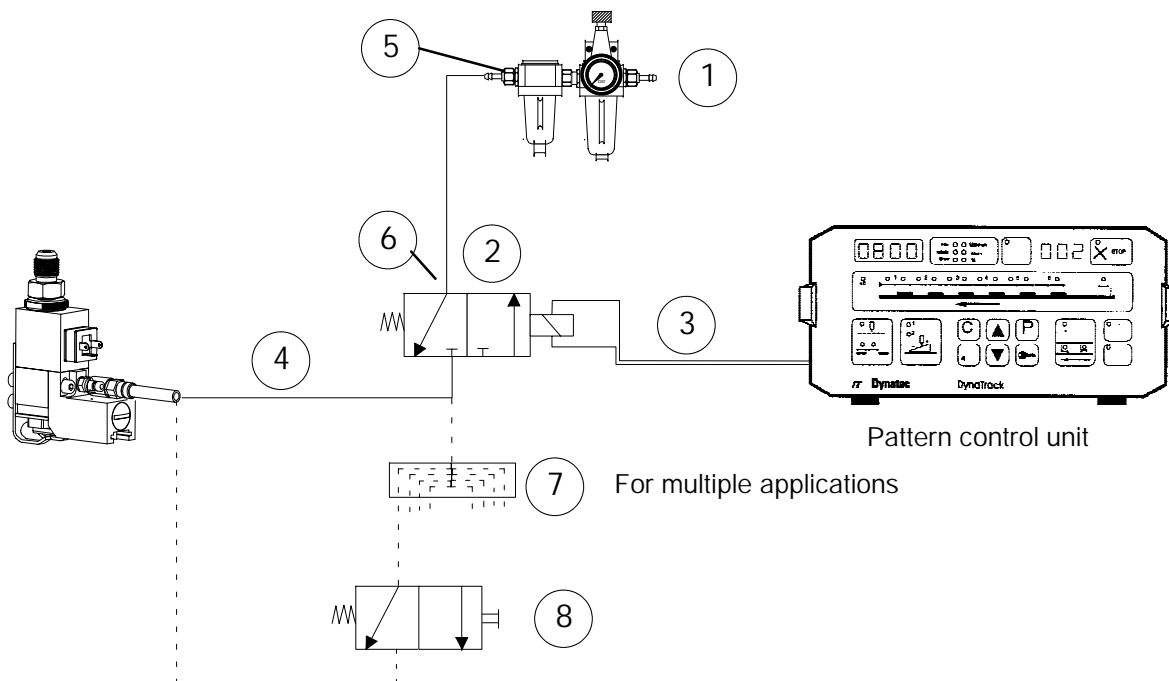

Item	Art. No.	Article
1	07.81106.702	Air filter/regulator unit
2	70.04000.709	3/2-port solenoid valve with accessories
3	05.02104.605	Solenoid valve initialization cable
4	07.08014.701	Quick connect air tubing
5	07.00600.117	Threaded connection
6	07.00600.117	Threaded connection
7	07.08014.701	Air manifold, 8 outputs
8	07.92200.001	2/2-port valve, manually-actuated

Decommissioning, packaging and transportation

Temporary decommissioning

1. Rinse the application heads with water.
2. Relieve residual pressure.
3. Render the application heads pressure and voltage-free.
4. Remove all glue residues and clean the nozzle/nozzle plate.
5. Remove all air and glue hoses and all electrical leads.
6. Fit all open threaded connections with sealing plugs or dust caps.
7. Package the application heads so that they are protected against corrosion.
8. Store the application heads so that they are protected against damage.

Permanent decommissioning and disposal

1. Switch the application heads off.
2. Relieve residual pressure.
3. Remove all glue residues.
4. Remove all air and glue hoses and all electrical leads.
5. Disassemble the application heads into mechanical and electrical components.
6. Dispose of the components for recycling.

Manual Modifications

Operating instructions drawn up: 9/00

Operating instructions modified:

Date	Page
3/01	complete

